

REFERENCE MANUAL



> DS5100
Barcode Scanner



Datalogic S.r.l.
Via S. Vitalino 13
40012 Calderara di Reno
Italy

DS5100 Reference Manual

Ed.: 08/2017

© 2017 Datalogic S.p.A. and/or its affiliates ♦ ALL RIGHTS RESERVED. ♦ Without limiting the rights under copyright, no part of this documentation may be reproduced, stored in or introduced into a retrieval system, or transmitted in any form or by any means, or for any purpose, without the express written permission of Datalogic S.p.A. and/or its affiliates.

Datalogic and the Datalogic logo are registered trademarks of Datalogic S.p.A. in many countries, including the U.S.A. and the E.U.

Genius, e-Genius, ACR, DST, EBC, ID-NET, PackTrack, Subzero, and X-PRESS are trademarks of Datalogic S.p.A. and/or its affiliates. All other trademarks and brands are property of their respective owners.

Datalogic shall not be liable for technical or editorial errors or omissions contained herein, nor for incidental or consequential damages resulting from the use of this material.

04/08/17

CONTENTS

REFERENCES	vi
Conventions.....	vi
Reference Documentation	vi
Support Through the Website.....	vi
Patents.....	vi
SAFETY AND COMPLIANCE NOTICES.....	vii
Laser Safety.....	vii
Power Supply.....	viii
FCC Compliance	ix
CE Compliance.....	ix
EAC Compliance	ix
Bureau of Indian Standard (BIS).....	ix
Handling.....	x
GENERAL VIEW	xii
1 RAPID CONFIGURATION	1
Step 1 – Connect the System	1
Step 2 – Mount and Position the Scanner	3
Step 3 – Focus the Scanner	5
Step 4 – X-PRESS Configuration	6
Step 5 – Install Genius Configuration Program	11
Step 6 – Test Mode	17
Advanced Scanner Configuration	18
2 INTRODUCTION	19
2.1 Product Description	19
2.1.1 Indicators	20
2.2 ID-NET.....	20
2.2.1 How To Setup/Configure the Scanner Network.....	22
2.3 X-PRESS Human Machine Interface.....	23
2.3.1 Diagnostic Indication.....	23
2.3.2 X-PRESS Functions	24
2.4 External Memory Backup & Restore.....	26
2.5 Automatic Scanner Replacement	29
2.6 Display	30
2.6.1 Display Messages.....	30
2.7 Model Description	34
2.8 Oscillating Mirror Models	35
2.9 Subzero Temperature Models	36
2.10 IP Address Alignment using Genius Discovery	37
2.11 Accessories	39
3 MECHANICAL INSTALLATION	42
3.1 Package Contents	42
3.2 Mechanical Installation	43
3.2.1 Mounting DS5100.....	50
3.3 Mounting Scanner Accessories	53
3.3.1 Mounting a GFC-40 Accessory Deflection Mirror	53
3.4 Positioning	54

4	ELECTRICAL INSTALLATION.....	56
4.1	Power Supply.....	57
4.2	Main Serial Interface.....	57
4.2.1	RS232 Interface.....	58
4.2.2	RS485 Full-Duplex Interface.....	59
4.3	ID-NET Interface.....	60
4.3.1	ID-NET Cables.....	60
4.3.2	ID-NET Response Time.....	61
4.3.3	ID-NET Network Termination.....	65
4.4	Auxiliary RS232 Interface.....	65
4.5	Inputs.....	66
4.5.1	Code Verifier.....	69
4.6	Outputs.....	69
4.7	User Interface - Host.....	71
5	TYPICAL LAYOUTS	72
5.1	Point-to-Point.....	72
5.2	External Fieldbus Using Host Mode Interface Modules.....	73
5.3	Built-In Ethernet Networks.....	74
5.3.1	External Trigger Ethernet Host.....	74
5.4	Built-in Profinet-IO Networks.....	75
5.4.1	Multi Station Layout with Single Port Scanners.....	75
5.4.2	Single Station Layout with Dual Port Scanners.....	76
5.4.3	Multi Station Layout with Dual Port Scanners.....	77
5.5	EBC™ Networks.....	78
5.6	ID-NET Synchronized Networks.....	83
5.7	ID-NET Multidata Networks.....	88
5.8	Pass-Through.....	89
5.9	Other Layouts.....	89
6	READING FEATURES.....	90
6.1	Advanced Code Reconstruction (ACR 4).....	90
6.1.1	Tilt Angle for Advanced Code Reconstruction.....	91
6.1.2	ACR Reading Conditions for Medium Range Models.....	92
6.1.3	ACR Reading Conditions for Long Range Models.....	94
6.2	Linear Code Reading.....	96
6.2.1	Step-Ladder Mode.....	96
6.2.2	Picket-Fence Mode.....	97
6.3	Performance.....	98
6.4	Reading Diagrams.....	100
6.4.1	Linear Medium Range Models.....	100
6.4.2	Linear Medium Range Subzero Models.....	105
6.4.3	Linear Long Range Models.....	110
6.4.4	Oscillating Mirror Medium Range Models.....	114
6.4.5	Oscillating Mirror Medium Range Subzero Models.....	119
6.4.6	Oscillating Mirror Long Range Models.....	124
7	MAINTENANCE	128
7.1	Cleaning.....	128
8	TROUBLESHOOTING	129
8.1	General Guidelines.....	129
9	TECHNICAL FEATURES.....	132

A	ALTERNATIVE CONNECTIONS FOR SERIAL MODELS	134
	Power, COM and I/O Connector	134
	ID-NET Network Termination.....	135
	Inputs	135
	Outputs	136
	User Interface - Serial Host	137
B	ALTERNATIVE CONNECTIONS FOR ETHERNET MODELS.....	138
	Power, COM and I/O Connector	138
	On-Board Ethernet Connector	139
	ID-NET Network Termination.....	139
	Inputs	139
	Outputs	140
C	CONNECTIONS FOR PROFINET-IO MODELS	142
	On-Board Profinet-IO Connectors (2)	142
	Power + Input (Trigger).....	142
	GLOSSARY.....	143
	INDEX.....	146

REFERENCES

CONVENTIONS

This manual uses the following conventions:

“User” or “Operator” refers to anyone using the scanner.

“Device” refers to the scanner.

“You” refers to the System Administrator or Technical Support person using this manual to install, mount, operate, maintain or troubleshoot the scanner.

REFERENCE DOCUMENTATION

The documentation related to the scanner management is listed below:

- CBX100 Installation Manual
- CBX500 Installation Manual
- CBX Accessory Manuals
- Genius Help On Line

SUPPORT THROUGH THE WEBSITE

Datalogic provides several services as well as technical support through its website. Log on to www.datalogic.com and click on the **SUPPORT > Unattended Scanning Systems** category link. From this page you can select your product model from the dropdown list which gives you access to:

- [Downloads](#) including Data Sheets, Manuals, Software & Utilities, and Drawings;
- [Repair Program](#) for On-Line Return Material Authorizations (RMAs) plus Repair Center contact information;
- [Service Program](#) containing details about Maintenance Agreements;
- [Technical Support](#) through email or phone.

PATENTS

See www.patents.datalogic.com for patent list.

This product is covered by one or more of the following patents:

Design patents: USD743397

Utility patents: EP0789315B1, EP0959426B9, EP1217571B1, EP2215583B1, EP2519856, IT0282308, JP4033958B2, JP4376353B2, US5992740, US6347740, US6394352, US6443360, US6629639, US6742710, US7161685, US8740079, US9104928, US9355292

SAFETY AND COMPLIANCE NOTICES



CAUTION: Subzero model scanners must not be opened in an uncontrolled environment.

LASER SAFETY

The following information is provided to comply with the rules imposed by international authorities and refers to the correct use of the DS5100 scanner.

Standard Regulations

This scanner utilizes a low-power laser diode. Although staring directly at the laser beam momentarily causes no known biological damage, avoid staring at the beam as one would with any very strong light source, such as the sun. Avoid that the laser beam hits the eye of an observer, even through reflective surfaces such as mirrors, etc.

This product conforms to the applicable requirements of IEC 60825-1 and complies with 21 CFR 1040.10 except for deviations pursuant to Laser Notice N° 50, date June 24, 2007. The scanner is classified as a Class 2 laser product according to IEC 60825-1 regulations.

There is a safety device, which allows the laser to be switched on only if the motor is rotating above the threshold for its correct scanning speed.

The laser beam can be switched off through a software command (see also the Genius Help On Line).



WARNING: Use of controls or adjustments or performance of procedures other than those specified herein may result in exposure to hazardous visible laser light.

The laser light is visible to the human eye and is emitted from the window on the front of the scanner ([Figure A](#), 4).

Warning labels indicating exposure to laser light and the device classification are applied onto the body of the scanner.

Disconnect the power supply when opening the device during maintenance or installation to avoid exposure to hazardous laser light.

The laser diode used in this device is classified as a class 3B laser product according to EN 60825-1 regulations and as a Class IIIb laser product according to CDRH regulations.

Any violation of the optic parts in particular can cause radiation up to the maximum level of the laser diode (60 mW at 630 to 680 nm).

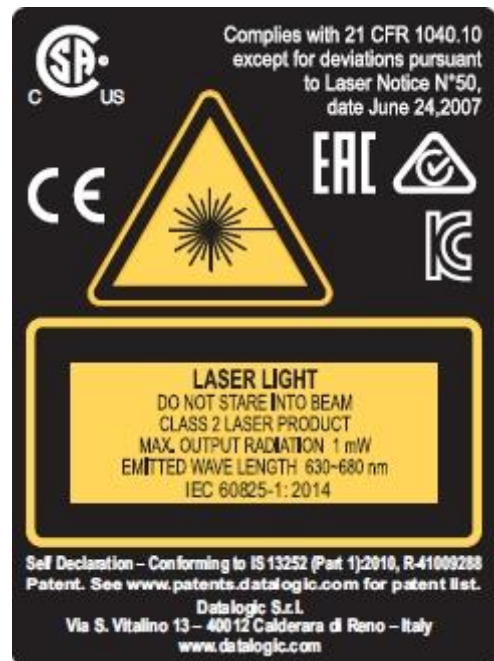

Warning and Device Class Labels

Produit(s) conforme selon 21CFR 1040.10 sauf des dérogations relatives à la Laser Notice N° 50, date Juin 24, 2007.

Dans le paquet il y a l'étiquette(s) pour les pays où le texte d'avertissement en français sont obligatoires. Le(s) mettre sur le produit à la place de la version anglaise.

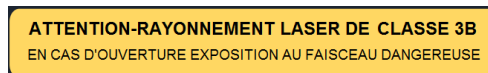

Exemple d'étiquettes d'avertissement laser

POWER SUPPLY

This product is intended to be installed by Qualified Personnel only.

This product is intended to be connected to a UL Listed or CSA Certified Power Unit marked LPS or "Class 2".

FCC COMPLIANCE

Modifications or changes to this equipment without the expressed written approval of Datalogic could void the authority to use the equipment.

This device complies with PART 15 of the FCC Rules. Operation is subject to the following two conditions: (1) This device may not cause harmful interference, and (2) this device must accept any interference received, including interference which may cause undesired operation.

This equipment has been tested and found to comply with the limits for a Class A digital device, pursuant to part 15 of the FCC Rules. These limits are designed to provide reasonable protection against harmful interference when the equipment is operated in a commercial environment. This equipment generates, uses, and can radiate radio frequency energy and, if not installed and used in accordance with the instruction manual, may cause harmful interference to radio communications. Operation of this equipment in a residential area is likely to cause harmful interference in which case the user will be required to correct the interference at his own expense.

CE COMPLIANCE

CE marking states the compliance of the product with essential requirements listed in the applicable European directive. Since the directives and applicable standards are subject to continuous updates, and since Datalogic promptly adopts these updates, therefore the EU declaration of conformity is a living document. The EU declaration of conformity is available for competent authorities and customers through Datalogic commercial reference contacts. Since April 20th, 2016 the main European directives applicable to Datalogic products require inclusion of an adequate analysis and assessment of the risk(s). This evaluation was carried out in relation to the applicable points of the standards listed in the Declaration of Conformity. Datalogic products are mainly designed for integration purposes into more complex systems. For this reason it is under the responsibility of the system integrator to do a new risk assessment regarding the final installation.

Warning

This is a Class A product. In a domestic environment this product may cause radio interference in which case the user may be required to take adequate measures.

EAC COMPLIANCE

Customs Union:

The CU Conformity certification has been achieved; this allows the Product to bear the Eurasian mark of conformity.

BUREAU OF INDIAN STANDARD (BIS)

Self Declaration – Conforming to IS 13252 (Part 1):2010, R-41009288.

HANDLING

The DS5100 is designed to be used in an industrial environment and is built to withstand vibration and shock when correctly installed, however it is also a precision product and therefore before and during installation it must be handled correctly to avoid damage.

- avoid that the scanners hit one another causing damage. They should be handled separately.

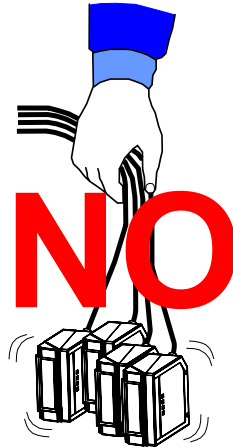

- avoid that the scanners are dropped (exceeding shock limits).



- do not fine tune the positioning by striking the scanner or bracket.

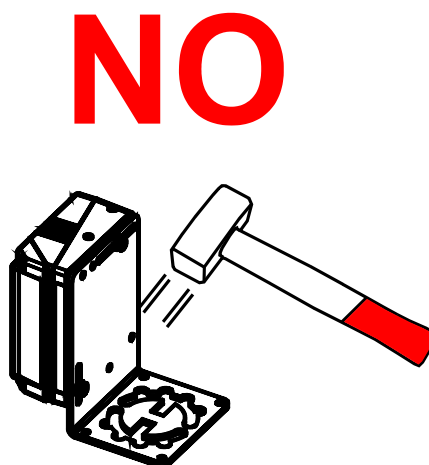

- do not weld the scanner into position which can cause electrostatic, heat or output window damage.

NO

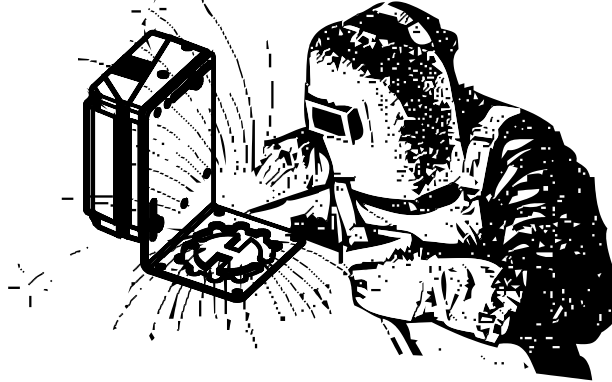

- do not spray paint near the scanner which can cause output window damage.

NO

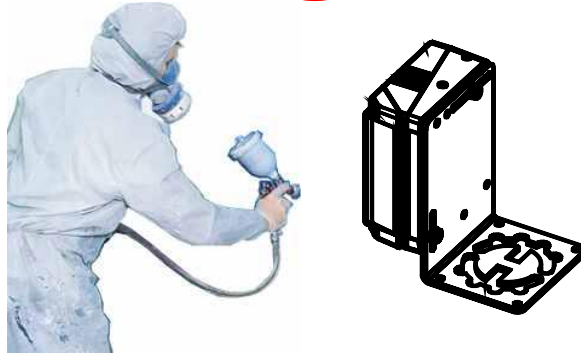

GENERAL VIEW

DS5100-X200 Serial Models



Figure A

- | | | | |
|---|-------------------------------------------------------------------|----|------------------------|
| 1 | Warning and Device Class Labels | 7 | Indicator LEDs |
| 2 | Power – Serial Interfaces – I/O Cable with 25-pin D-sub connector | 8 | Network LEDs |
| 4 | Laser Beam Output Window | 9 | Power On LED |
| 5 | Mounting Holes (7) | 10 | Focus Adjustment Screw |
| 6 | Display | 11 | X-PRESS™ Push Button |

DS5100-X300

Built-in Ethernet Models



Figure B

- | | |
|-------------------------------------------------------------------------------------------------------------------------------------------------------------------------------------------------------------------------------------------------------------|----------------------------------------------------------------------------------------------------------------------------------------------------------------------------------------|
| <ul style="list-style-type: none"> 1 Warning and Device Class Labels 2 Power – Serial Interfaces – I/O Connector 3 Ethernet Connector 4 Laser Beam Output Window 5 Mounting Holes (7) 6 Display | <ul style="list-style-type: none"> 7 Indicator LEDs 8 Network LEDs 9 Power On LED 10 Focus Adjustment Screw 11 X-PRESS™ Push Button |
|-------------------------------------------------------------------------------------------------------------------------------------------------------------------------------------------------------------------------------------------------------------|----------------------------------------------------------------------------------------------------------------------------------------------------------------------------------------|

Connector block rotates to 90° position.

DS5100-X400 Profinet-IO Models



Figure C

- | | | | |
|---|--------------------------------------|----|------------------------|
| 1 | Warning and Device Class Labels | 7 | Indicator LEDs |
| 2 | Power – Trigger Input Connector | 8 | Network LEDs |
| 3 | Profinet-IO – EBC Network Connectors | 9 | Power On LED |
| 4 | Laser Beam Output Window | 10 | Focus Adjustment Screw |
| 5 | Mounting Holes (7) | 11 | X-PRESS™ Push Button |
| 6 | Display | | |

Connector block rotates to 90° position.

DS5100-XX20

OM Models

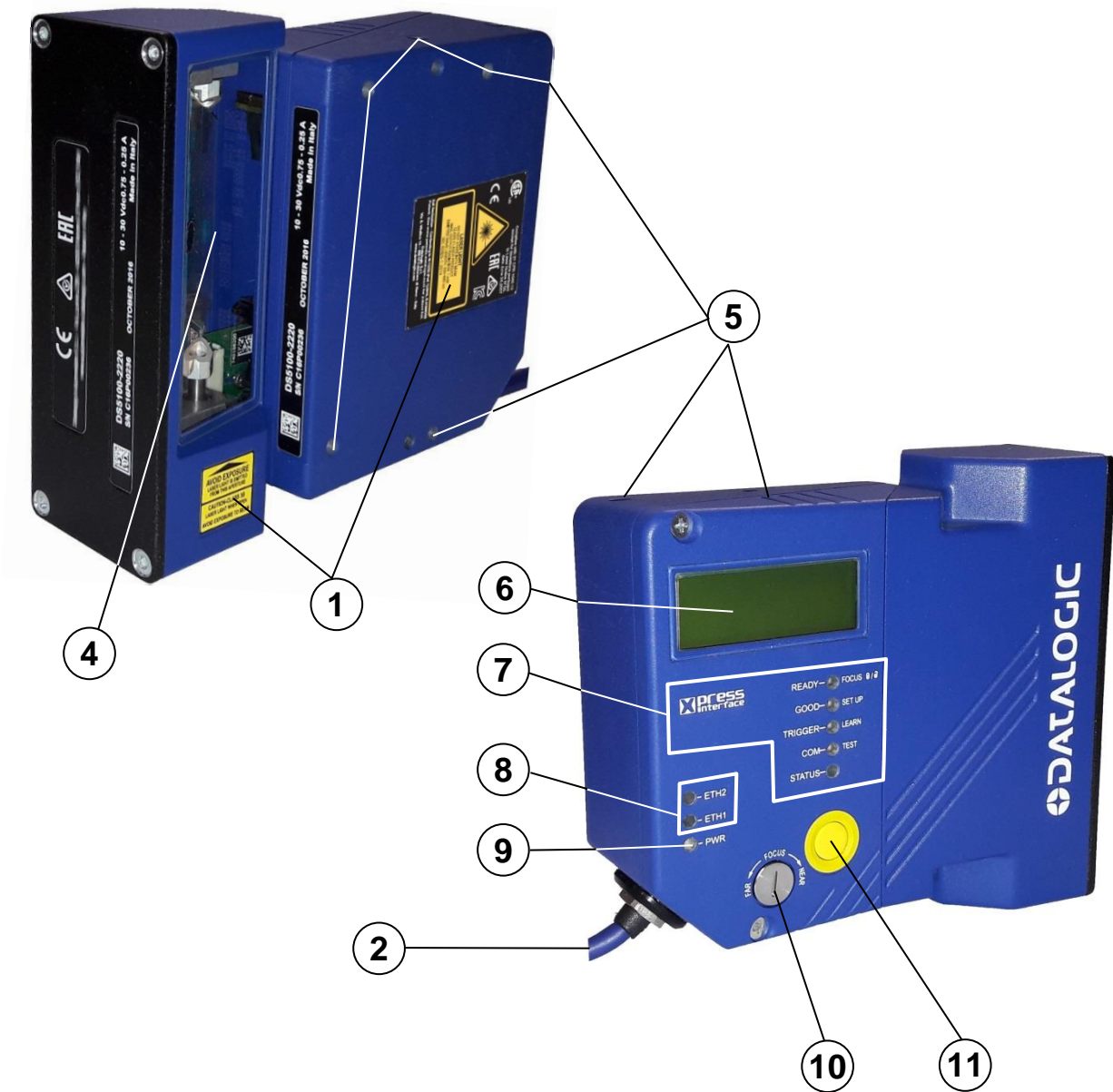

Figure D

- | | | | |
|---|-------------------------------------------------------------------|----|------------------------|
| 1 | Warning and Device Class Labels | 7 | Indicator LEDs |
| 2 | Power – Serial Interfaces – I/O Cable with 25-pin D-sub connector | 8 | Network LEDs |
| 3 | Laser Beam Output Window | 9 | Power On LED |
| 4 | Mounting Holes (7) | 10 | Focus Adjustment Screw |
| 5 | Display | 11 | X-PRESS™ Push Button |

DS5100-XX05 Subzero™ Models



Figure E

- | | | | |
|---|-------------------------------------------|----|------------------------|
| 1 | Warning and Device Class Labels | 7 | Indicator LEDs |
| 2 | Power – Serial Interfaces – I/O Connector | 8 | Network LEDs |
| 3 | Ethernet Connector | 9 | Power On LED |
| 4 | Laser Beam Output Window w/ heater | 10 | Focus Adjustment Screw |
| 5 | Mounting Holes (7) | 11 | X-PRESS™ Push Button |
| 6 | Display | 12 | Subzero™ Logo |

Connector block rotates to 90° position.

1 RAPID CONFIGURATION



NOTE: This chapter illustrates a Stand Alone application. For other types of installations, such as ID-NET, Fieldbus, Pass-Through layouts, etc., refer to chapters 4, and 5. For complete scanner configuration using the Genius configuration program, refer to the Context-Sensitive Help On-Line.

STEP 1 – CONNECT THE SYSTEM

To connect the system in a Stand Alone configuration, you need the hardware indicated in Figure 1.

In this layout the data is transmitted to the Host on the main serial interface.

In Local Echo communication mode, the RS232 auxiliary interface can be used to transmit data independently from the main interface selection.

When On-Line Operating mode is used, the scanner is activated by an External Trigger (photoelectric sensor) when the object enters its reading zone.

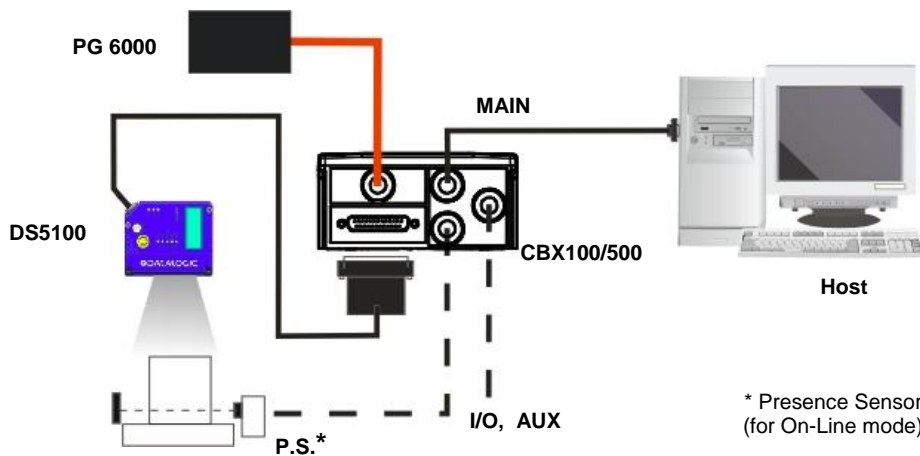

Figure 1 – Scanner Connected to a Serial Host in a Stand Alone Layout

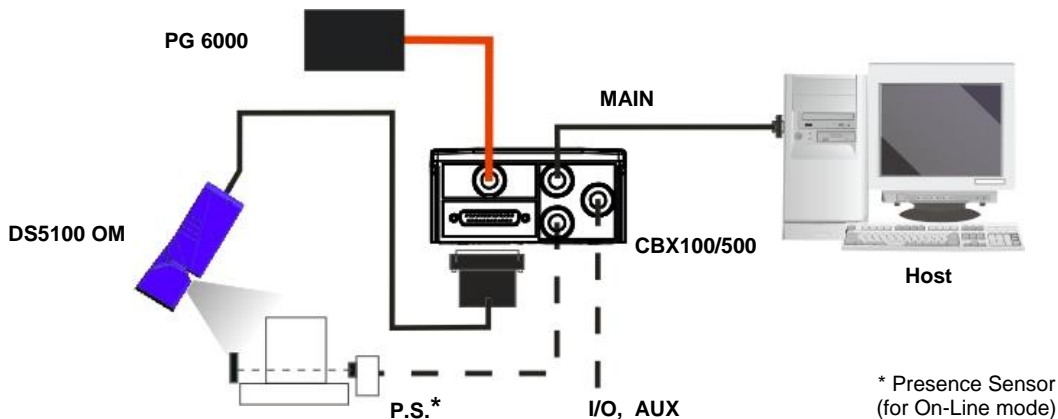

Figure 2 – OM Model Scanner Connected to a Serial Host in a Stand Alone Layout

CBX100/500 Pinout for DS5100

The table below gives the pinout of the CBX100/500 terminal block connectors. Use this pinout when the DS5100 reader is connected by means of the CBX100/500:

CBX100/500 Terminal Block Connectors			
Input Power		Outputs	
Vdc	Power Supply Input Voltage +	+V	Power Source - Outputs
GND	Power Supply Input Voltage -	-V	Power Reference - Outputs
Earth	Protection Earth Ground	O1+	Output 1 +
		O1-	Output 1 -
Inputs		O2+	Output 2 +
+V	Power Source – External Trigger	O2-	Output 2 -
I1A	External Trigger A (polarity insensitive)	Auxiliary Interface	
I1B	External Trigger B (polarity insensitive)	TX	Auxiliary Interface TX
-V	Power Reference – External Trigger	RX	Auxiliary Interface RX
+V	Power Source – Inputs	SGND	Auxiliary Interface Reference
I2A	Input 2 A (polarity insensitive)	ID-NET	
I2B	Input 2 B (polarity insensitive)	REF	Network Reference
-V	Power Reference – Inputs	ID+	ID-NET network +
Shield		ID-	ID-NET network -
Shield	Network Cable Shield		
Main Interface			
	RS232	RS485 Full-Duplex	
	TX	TX+	
	RTS	TX-	
	RX	*RX+	
	CTS	*RX-	
	SGND	SGND	

* Do not leave floating, see par. 4.2.2 for connection details.



CAUTION: Do not connect GND, SGND and REF to different (external) ground references. GND, SGND and REF are internally connected through filtering circuitry which can be permanently damaged if subjected to voltage drops over 0.8 Vdc.

STEP 2 – MOUNT AND POSITION THE SCANNER

DS5100 Standard and Subzero Models

1. To mount the scanner, use the mounting bracket to obtain the most suitable position for the reader as shown in the figures below.

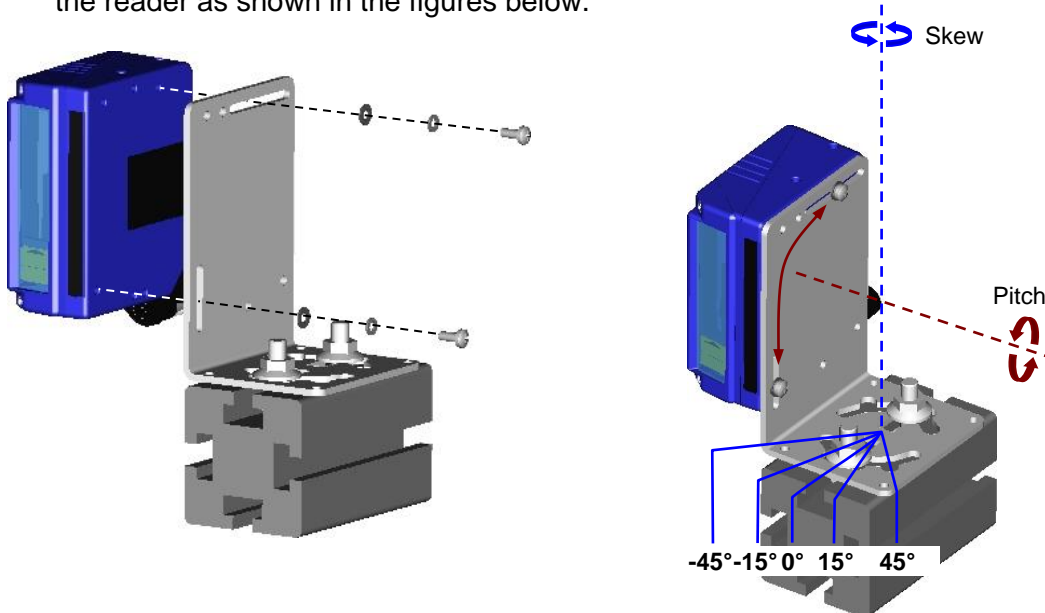

Figure 3 - Positioning with Mounting Bracket

2. When mounting the scanner take into consideration these three ideal label position angles: **Skew 15° to 30°, Tilt 0° and Pitch 0°.**

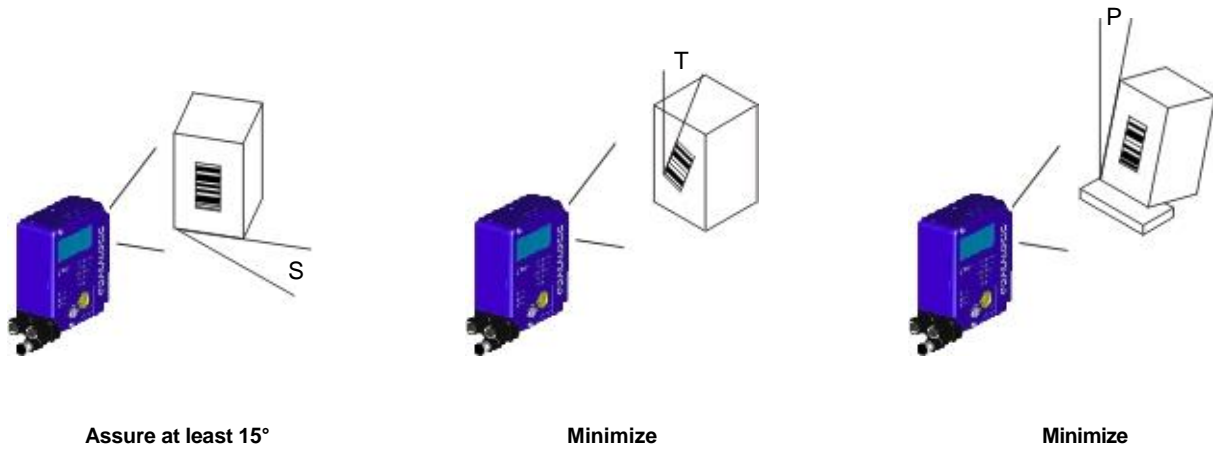

Figure 4 –Skew, Tilt and Pitch Angles

3. Refer to the Reading Diagrams in par. 6.4 to decide the distance your scanner should be positioned at.

DS5100 OM Models

1. To mount the DS5100 OM, use the mounting bracket to obtain the most suitable position for the reader as shown in the figures below.

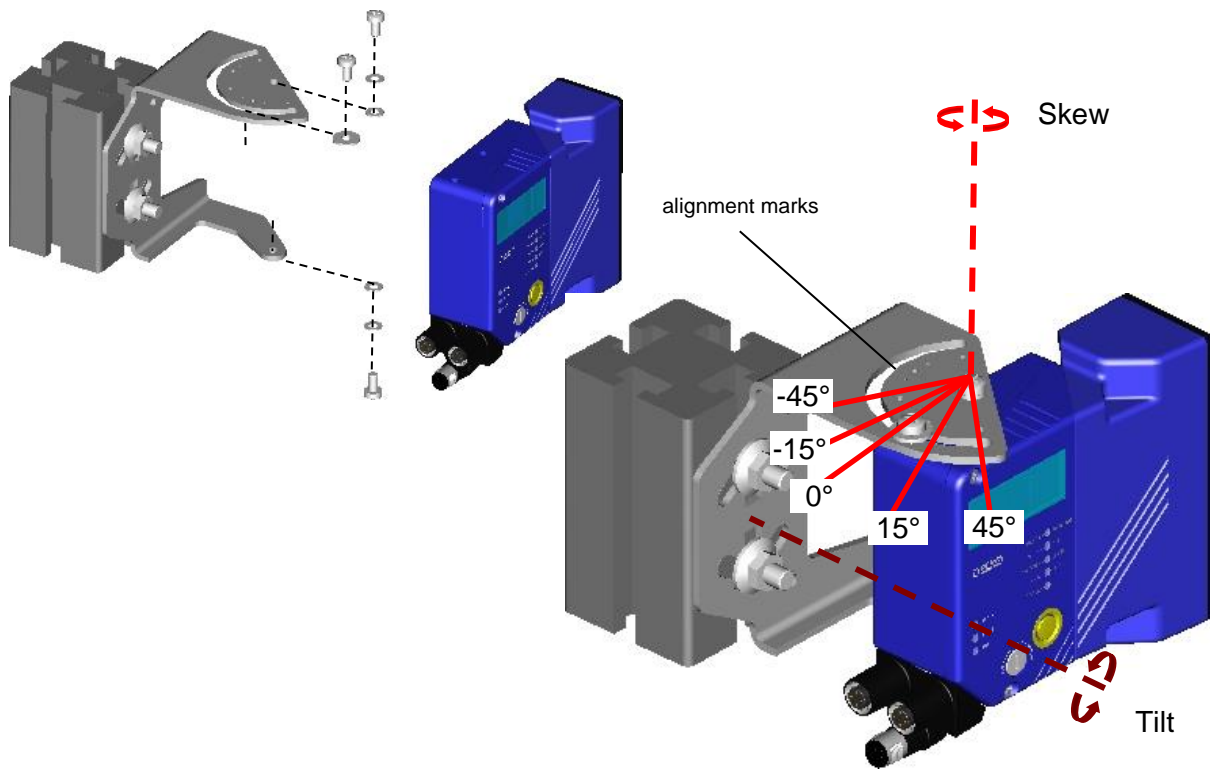

Figure 5 - Positioning with Mounting Bracket

2. When mounting the DS5100 OM take into consideration these three ideal label position angles: **Skew 15° to 30°**, **Tilt 0°** and **Pitch 0°**. The Skew angle refers to the most inclined or external raster line, so that all other raster lines assure **more** than 15° Skew.

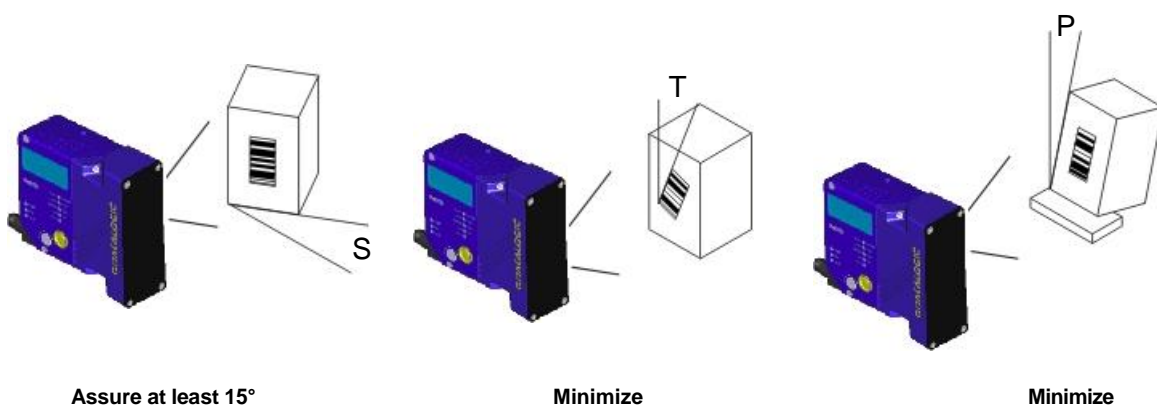

Figure 6 -Skew, Tilt and Pitch Angles

3. Refer to the Reading Diagrams in par. 6.4 to decide the distance your scanner should be positioned at.

STEP 3 – FOCUS THE SCANNER

The reading distance depends on the focus distance of the scanner and should be set according to the application requirements. The Focus Position is set directly through the focus adjustment screw on the front panel of the scanner. This screw moves the internal lens of the scanner to change the focal point of the scanner. The setting is continuous but should not be set beyond the limits "Too Far" or "Too Near" which appear on the display at the extremes of the focus range. Although the scanner reads across the entire focus range, there are three guaranteed positions which correspond to the reading diagrams in par. 6.4.

1. Power up the scanner. **For Subzero models, At -35 °C, a 20-minute warm-up period is required before the scanner is ready to read barcodes, the Ready LED blinks.** Wait for the power up sequence to finish. By default the scanner focus is in the Unlocked position. The alternating message on the display shows the mechanical Focus Position as well as the message "Please Lock Focus!" on the scanner display.
2. Using a screwdriver turn the focus adjustment screw in the desired direction, clockwise (focus nearer to the scanner) or counterclockwise (focus farther from the scanner). The focus position in centimeters and inches is shown on the scanner display.



NOTE: After correctly focusing the scanner, it is strongly recommended to store the value of the Focus Position in memory (Locked Position parameter). When Locked, if the mechanical position changes by more than the allowed tolerance of the value in memory, a diagnostic alarm will be sent to the display. See the [Focus Lock function](#) in step 4, X-PRESS Configuration.

As an additional visual aid during focusing, the indicator LEDs show the relative focus position as follows:

	READY—○ FOCUS 0/0 GOOD—○ SETUP TRIGGER—○ LEARN COM—● TEST STATUS—●	READY—○ FOCUS 0/0 GOOD—○ SETUP TRIGGER—○ LEARN COM—● TEST STATUS—○	READY—○ FOCUS 0/0 GOOD—○ SETUP TRIGGER—● LEARN COM—● TEST STATUS—○	READY—○ FOCUS 0/0 GOOD—○ SETUP TRIGGER—● LEARN COM—○ TEST STATUS—○
Model				
1xxx	→ less than 30 cm	← → 30 cm NEAR	← → 32-38 cm	← → 40 cm MEDIUM
2xxx	less than 45 cm	45 cm NEAR	47-63 cm	65 cm MEDIUM

	READY—○ FOCUS 0/0 GOOD—● SETUP TRIGGER—● LEARN COM—○ TEST STATUS—○	READY—○ FOCUS 0/0 GOOD—● SETUP TRIGGER—○ LEARN COM—○ TEST STATUS—○	READY—● FOCUS 0/0 GOOD—● SETUP TRIGGER—○ LEARN COM—○ TEST STATUS—○
Model			
1xxx	← → 42-58 cm	← → 60 cm FAR	← more than 60 cm
2xxx	67-73 cm	75 cm FAR	more than 75 cm

STEP 4 – X-PRESS CONFIGURATION

X-PRESS is the intuitive Human Machine Interface designed to improve ease of installation and maintenance.

Status and diagnostic information are clearly presented by means of the colored LEDs, whereas the single push button gives immediate access to the following relevant functions:

- *AutoSetup* to self-optimize and auto-configure reading performance in demanding applications
- *AutoLearn* to self-detect and auto-configure for reading unknown barcodes (by type and length)
- *Focus Lock* to memorize the mechanical focus position
- *Test Mode* with bar graph visualization to check static reading performance
- *EBC/Profinet-IO network selection* to set the scanner as a Slave in an EBC network. (only for on-board Profinet 2 port models).

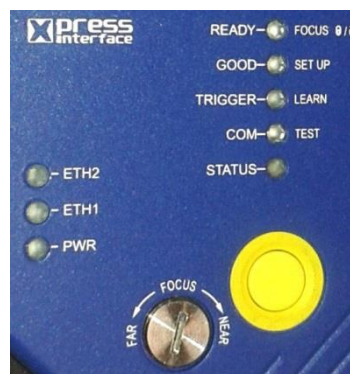

NOTE: When entering the X-PRESS interface on the DS5100-xx2x the Oscillating Mirror remains in the default **fixed position** (0°) in order to make barcode reading easier while performing the X-PRESS functions.

The colors and meaning of the indicator LEDs are illustrated in the following table:

LED	Color	Description
READY	Green	Indicates the device is ready to operate. For Subzero models this LED blinks during the warm-up phase.
GOOD	Green	Confirms successful reading.
TRIGGER	Yellow	Indicates the status of the reading phase. *
COM	Yellow	Indicates active communication on main serial port. **
STATUS	Red	Indicates a NO READ result.
ETH2	Yellow	Indicates connection to the on-board Profinet-IO network port 2. Not used on other models.
ETH1	Yellow	Indicates connection to the on-board Ethernet or on-board Profinet-IO network port 1. Not used on Serial models.
PWR	Blue	Indicates that the reader is connected to the power supply.

* In On-Line mode the TRIGGER LED corresponds to the active reading phase signaled by the Presence Sensor. In Automatic and Continuous modes the TRIGGER LED is always on indicating that the reader is ready to read a code.

** When connected to a Fieldbus network through a Host Interface Module inside the CBX500 or through a QLM, the COM LED is always active, even in the absence of data transmission, because of polling activity on the Fieldbus network.

During the reader startup (reset or restart phase), the first five LEDs blink for one second.

Auto Learn

If you are configuring your scanner using X-PRESS, you must start with the *Auto Learn* procedure.

1. Enter the *Auto Learn* function by holding the X-PRESS push button pressed until the LEARN LED is on.
2. Release the button to enter the *Auto Learn* function.
Once entered, the reader starts a procedure to automatically detect and recognize barcodes (by type and length), which are presented to it (*). The laser turns on and the LEARN LED blinks to indicate the ongoing process.



Figure 7 – X-PRESS Interface: Auto Learn Function

The procedure is as follows:

- A) **place** the desired barcode on the scanline.
- B) **wait** until the LEARN LED stays steady on (indicating the reader has detected the barcode).
- C) **repeat**, if needed, the above two steps to program up to 10 different barcodes (the LEARN LED returns to the blinking state for the next code). If more than one barcode is detected in the scan line, the Multi Label mode is enabled (refer to the “5K Family Software Configuration Parameter Guide” Help file).

3. **Exit** the process by pressing the X-PRESS push button once. The scanner will restart at the end of the process, and then the detected barcodes are automatically configured in scanner memory.



NOTE: If the barcode cannot be read because of low contrast or excessive ambient light, you can perform the AutoSetup function to optimize the optical parameters. Then you can perform AutoLearn to recognize the barcode symbology.



NOTE: On exit from Autolearn, the following parameters are forced: Code Combination = Single Label, Reading Mode = Linear. If necessary, these parameters can be changed through Genius.

* In case of Programming Barcodes, refer to the “Setup Procedure Using Programming Barcodes” document in the downloadable Genius mini-DVD zip file.

Auto Setup (Optional)

At the end of the *Auto Learn* procedure, you have the possibility to follow the *Auto Setup* procedure to set up the reading parameters.

1. Enter the *Auto Setup* function by holding the X-PRESS push button pressed until the SETUP LED is on.
2. Release the button to enter the *Auto Setup* function.
3. Once entered, if a barcode label is positioned in front of the scanline, the scanner automatically performs the optimal setup of the reading parameters for that specific barcode.

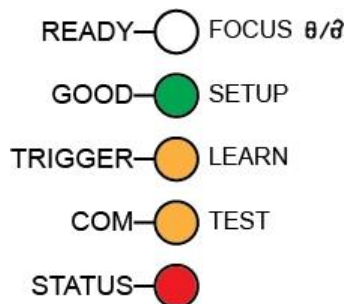

Figure 8 – X-PRESS Interface: Auto Setup Function

The procedure is as follows:

- A) **place** the desired barcode on the scanline.
- B) **enter** the AutoSetup function (the laser turns on and the SETUP LED blinks to indicate the ongoing process)
- C) **wait** until the SETUP LED stays steady on (indicating the reader has detected the barcode)

This procedure ends either when the barcode is successfully decoded or after a timeout of about 7 (seven) seconds.

The scanner will restart at the end of the process, and then the optimized reading parameters for that barcode are automatically configured in scanner memory.

Focus Lock/Unlock

You must perform the *Focus Lock* procedure to save the mechanical focus position to memory. When Locked, if the mechanical focus position is changed by more than the allowed tolerance of the value in memory, a diagnostic alarm will be sent to the display. See par. 2.3.1 for details.



NOTE: For Stand Alone or Master devices, the diagnostic alarm can also be sent to any of the desired communication channels by selecting it in the Diagnostic>Actions branch of the Genius configuration tool.

1. Enter the Focus Lock function by holding the X-PRESS push button pressed until the FOCUS LOCK LED is on.
2. Release the button to enter the *Focus Lock* function. Once entered, the scanner automatically performs the Lock (saving) or Unlock procedure depending on the previous state of the Locked Position parameter.

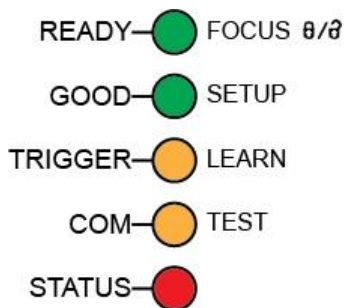

Figure 9 – X-PRESS Interface: Focus Lock/Unlock Function

The procedure is as follows:

- A) **enter** the Focus Lock function
- B) **wait** until the "Focus locked at..." message appears on the display (indicating the focus position has been saved to memory). The following parameters are set:
 - Locked Position = your mechanical setting
 - Focus Displacement (Alarm) = set (default to display only)

The scanner will be reset at the end of the process. The LEDs turn off, the Display goes blank and then the Ready LED will turn on indicating the scanner is ready.



NOTE: If your application has been configured using X-PRESS, go to STEP 6.

EBC/Profinet-IO Network Selection (only on Profinet-IO dual port models)

For on-board Profinet 2 port models, the DS5100 scanner can be configured to work as a Slave in an EBC network. **The only way to make this selection is through the X-PRESS button.**

1. Enter the EBC/Profinet-IO Network Selection function by holding the X-PRESS push button pressed until the all X-PRESS LEDs are off.
2. Release the button to enter the *Network Selection* function. Once entered, the scanner automatically performs the procedure to set itself as either an EBC slave or a Profinet-IO slave depending on the previous state of the network selection.

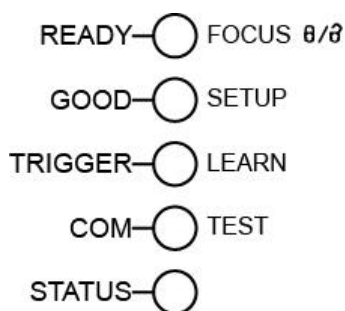

Figure 10 – X-PRESS Interface: EBC/Profinet-IO Network Selection Function

The procedure is as follows:

- A) **enter** the Network selection function.
- B) **wait** until the "EBC Slave" or "Profinet-IO" message appears on the display (indicating the scanner has been set and saved).

The scanner will restart at the end of the process.



NOTE: To reset the scanner to its default Profinet interface settings, you can also perform the *Reset Scanner to Factory Default* procedure as described in the paragraph below.

Reset Scanner to Factory Default (Optional)

If it ever becomes necessary to reset the scanner to the factory default values, you can perform this procedure by holding the X-PRESS push button pressed while powering up the scanner and waiting for all the X-PRESS LEDs to blink simultaneously three times before releasing the push button.

This procedure takes ≈ 5-6 seconds for Serial Models, ≈ 10 seconds for Ethernet Models, ≈ 20 seconds for 2 port Profinet-IO models. At the end of the procedure the Configuration and Environmental parameters are reset and the message "Default Set" is shown on the scanner display. If connected through a CBX500 with BM150 display module, the "Default Set" message is also shown on the CBX500 display.

STEP 5 – INSTALL GENIUS CONFIGURATION PROGRAM

Genius is a Datalogic scanner configuration tool providing several important advantages:

- Wizard approach for new users;
- Multi-language version;
- Defined configuration directly stored in the reader;
- Communication protocol independent from the physical interface allowing to consider the reader as a remote object to be configured and monitored.

To install Genius, on the PC that will be used for configuration, (running Windows XP, or 7), download the Genius mini-DVD .zip file. Extract the files to a local folder and launch the Setup.exe file. Select Install Genius and follow the installation procedure.

This configuration procedure assumes scanner connection to a CBX100/500. Genius, running on a laptop computer, is connected to the scanner auxiliary port through the CBX100/500 9-pin connector. To communicate with the scanner, Genius performs an auto baudrate detection starting from its default parameters which are 115200, 8, N, 1. These parameters can also be set in the Genius Tools>Options>Communications window.

Wizard for Quick Reader Setup

After installing the Genius software program the following window appears asking the user to choose the desired configuration level.



Figure 11 - Genius Wizard Opening Window

The Wizard option is advised for rapid configuration or for new users, since it shows a step-by-step scanner configuration.

1. Select the *Create a new configuration* button.



You will be guided through the configuration being asked to define the following parameters:

- a. Barcode selection and definition



b. Operating mode selection and definition

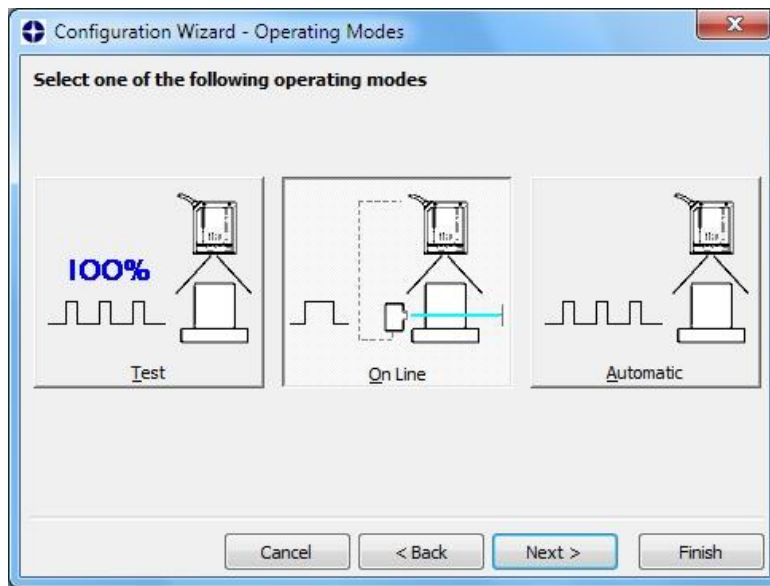

a. Digital Inputs configuration

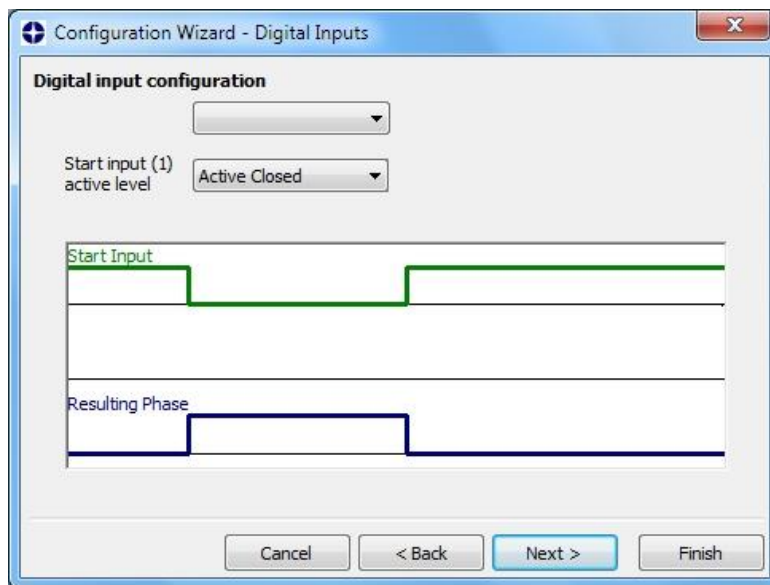

b. Digital Outputs configuration

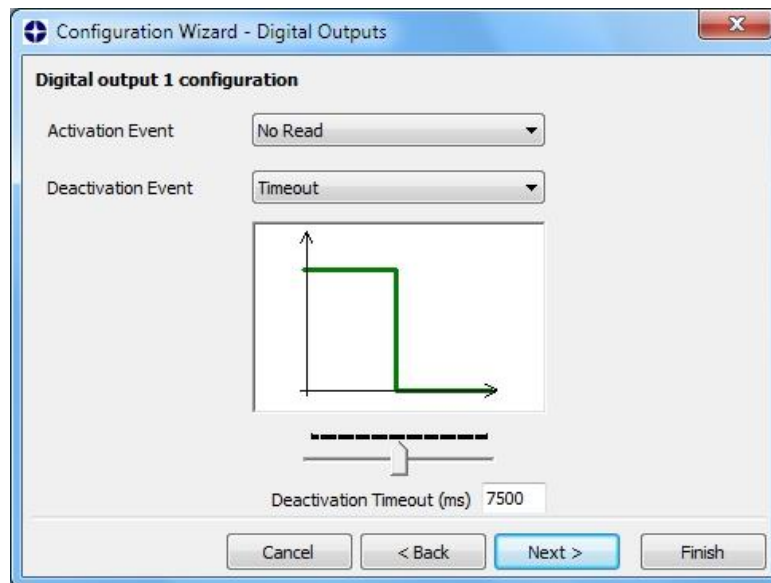

c. Hardware interface selection

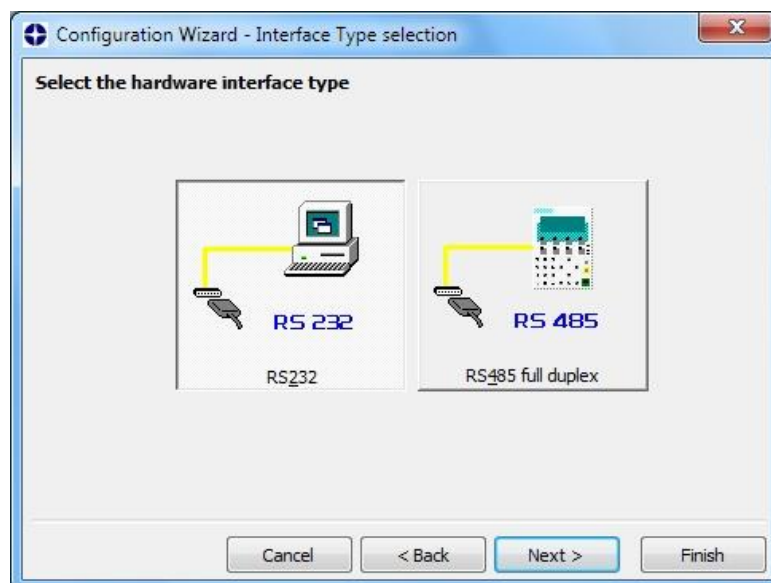

d. Output data format configuration

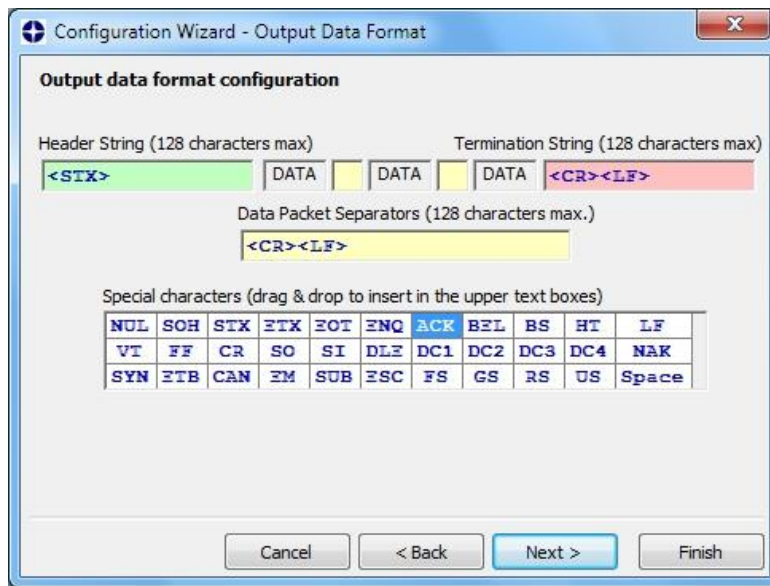

The **On Line** operating Mode requires the reader to be connected to an External Trigger/Presence Sensor using I1A and I1B inputs.

The **Automatic** operating mode does not require connection to an external Presence Sensor. When working in this mode the reader is continuously scanning, while the reading phase is activated each time a barcode enters the reader reading zone. The reader stops reading after an N number of scans without a code. Barcode characters are transmitted on the serial interface. In case of a failed reading phase no message is sent to the host computer.

2. After defining the parameter values the following window appears allowing to complete the reader configuration as follows:
 - Saving the configuration to disk;
 - Switching to Advanced mode;
 - Sending the configuration to the scanner.

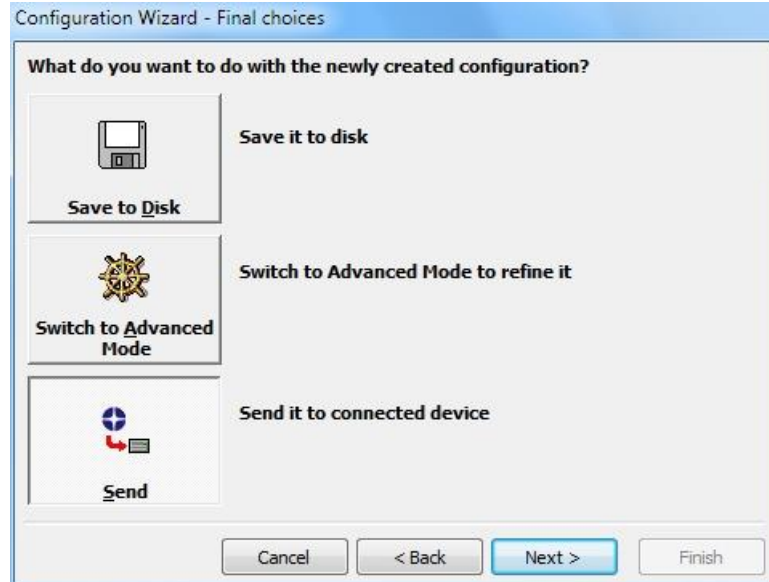

3. After sending the configuration to the scanner you have completed the configuration process.

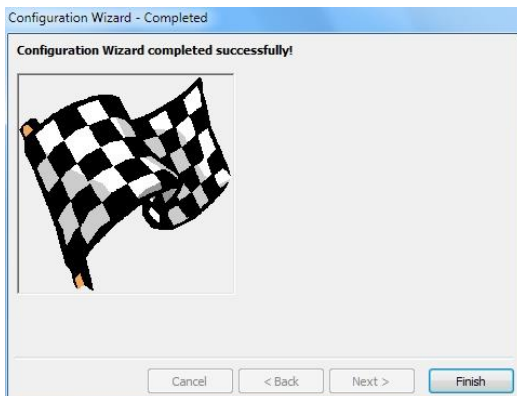

4. By clicking Finish, the System Information window will be displayed with specific information concerning the scanner.

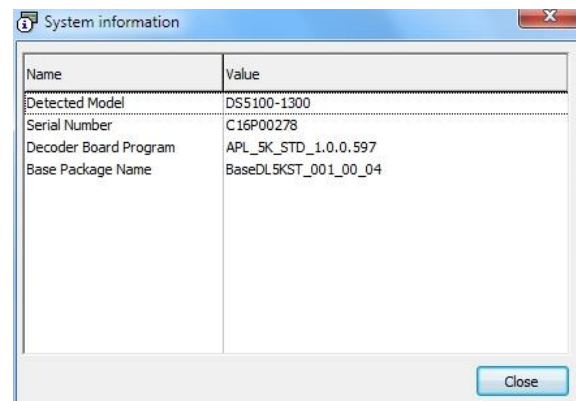

STEP 6 – TEST MODE



NOTE: When entering the X-PRESS interface on the DS5100-XX2X the Oscillating Mirror remains in the default **fixed position** (0°) in order to make barcode reading easier while performing the X-PRESS functions.

Use a code suitable to your application to test the system. Alternatively, you can use the Datalogic Test Chart (Code 128).

1. Enter the *Test mode* function by holding the X-PRESS push button pressed until the TEST LED is on.
2. Release the button to enter the *Test mode* function.
Once entered, the Bar-Graph on the five LEDs is activated and if the scanner starts reading barcodes the Bar-Graph shows the Good Read Rate. In case of no read condition, only the STATUS LED is on and blinks.



Figure 12 – X-PRESS Interface: Test Mode Function

3. To exit the Test Mode, press the X-PRESS push button once.



NOTE: By default, the Test Mode exits automatically after two minutes.

ADVANCED SCANNER CONFIGURATION

The ADVANCED configuration mode (instead of the Wizard) is available when starting the Genius program and is addressed to expert users being able to complete a detailed scanner configuration. By choosing this option it is possible either to start a new scanner configuration or to open and modify an old one. The desired parameters can be defined in the following window, similar to the MS Explorer:

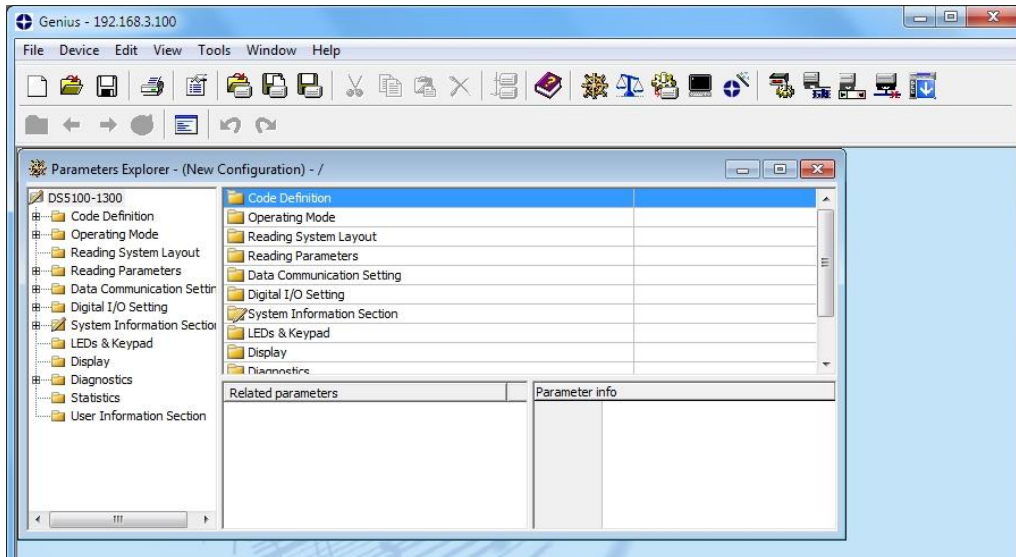

Figure 13 - Genius Parameter Explorer Window

Host Mode Programming

The scanner can also be configured from a host computer using the Host Mode programming procedure, by commands via the serial interface. See the Host Mode Programming manual on the downloadable Genius mini-DVD zip file.

Alternative Layouts

- The ID-NET network is a built-in high-speed interface dedicated for high-speed scanner interconnection. ID-NET is in addition to the Main and Auxiliary serial interfaces. If you need to install an ID-NET network refer to chapters 4 and 5 of this Reference Manual.

The scanner can also be configured by reading programming barcodes. See the "Setup Procedure Using Programming Barcodes" printable from the downloadable Genius mini-DVD zip file.

- If you need to install an Ethernet network, Fieldbus network or Pass-Through network, refer to chapters 4 and 5 of this Reference Manual.

2 INTRODUCTION

2.1 PRODUCT DESCRIPTION

The DS5100 laser scanner satisfies the most advanced needs of a wide range of users. It has been developed focusing on the realistic requirements of its target market. The outstanding result is an extremely compact, cost-effective and easy to use industrial scanner.

Standard Application Program A standard application program is factory-loaded onto the scanner. This program controls barcode reading, serial port interfacing, data formatting and many other operating and control parameters.

It is completely configurable from a host computer through the Genius utility program provided on the downloadable Genius mini-DVD zip file, or via the serial interface (Genius based Host Mode Programming).

Custom Application Programs If the Standard Application Program does not meet your requirements, please contact your local Datalogic distributor.

Some of the main features are listed below:

- Medium, Long Range, Linear and Oscillating Mirror models, user selectable focus for high application flexibility
- ID-NET™ and EBC™ (Ethernet Bus Connections)
- Embedded PROFINET-IO and EtherNet/IP for connectivity to main industrial Fieldbus
- X-PRESS™ interface, Genius™ software tool, embedded multi-language display for easy scanner setup and maintenance
- Rotating connector block for flexible form factor and easy installation
- DST™ (Digital Signal Technology)
- ACR4™ reconstruction technology
- PackTrack™ (only for Long Range models working in EBC)
- Superior ambient light immunity from high frequency laser modulation
- Top industrial grade, IP65 and Subzero™ version for low temperature environments

The scanner uses a solid-state laser diode as a light source; the light emitted has a wavelength between 630 and 680 nm. Refer to the section “Safety Precautions” at the beginning of this manual for information on laser safety.

The protection class of the enclosure is IP65, the reader is therefore suitable for industrial environments where high protection against harsh external conditions is required.

2.1.1 Indicators

The five LEDs on the side of the scanner ([Figure A, B, C, D, E, 7](#)) indicate the following:

LED	Color	Description
READY	Green	This LED indicates the device is ready to operate. For Subzero models this LED blinks during the warm-up phase.
GOOD	Green	This LED confirms successful reading.
TRIGGER	Yellow	This LED indicates the status of the reading phase. *
COM	Yellow	This LED indicates active communication on main serial port. **
STATUS	Red	This LED indicates a NO READ result.

* In On-Line mode the TRIGGER LED corresponds to the active reading phase signaled by the Presence Sensor. In Automatic and Continuous modes the TRIGGER LED is always on indicating that the reader is ready to read a code.

** When connected to a Fieldbus network through the CBX500, the COM LED is always active, even in the absence of data transmission, because of polling activity on the Fieldbus network.

During the reader startup (reset or restart phase), all the LEDs blink for one second.

PWR (blue)	This LED indicates that the reader is connected to the power supply.
ETH (yellow)	This LED indicates connection to the on-board Ethernet or Profinet-IO network.

2.2 ID-NET

The ID-NET network is a built-in high-speed interface dedicated for high-speed scanner interconnection. ID-NET is in addition to the Main and Auxiliary serial interfaces.



The following network configurations are available:

- **ID-NET Synchronized:** Single station – multiple scanners

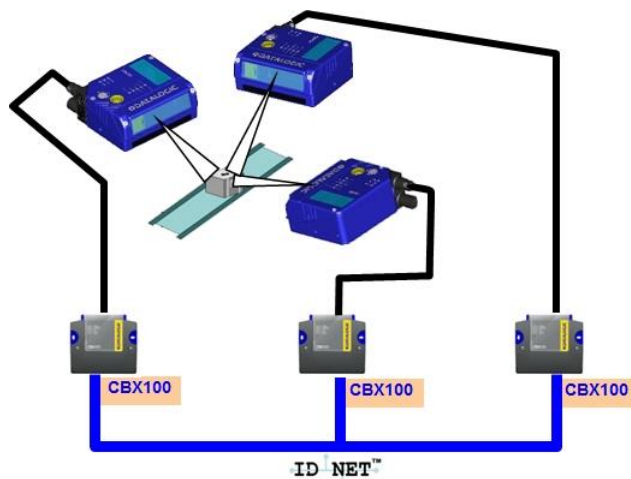

ID-NET interface allows local connection of multiple scanners reading different sides of the same target. All scanners share a single presence sensor and activate/deactivate simultaneously.

At the end of each reading phase a single data message is transmitted to the host.

Thanks to ID-NET, data communication among scanners is highly efficient so that an immediate result will be available.

- **ID-NET Multidata:** Multiple stations – single scanner

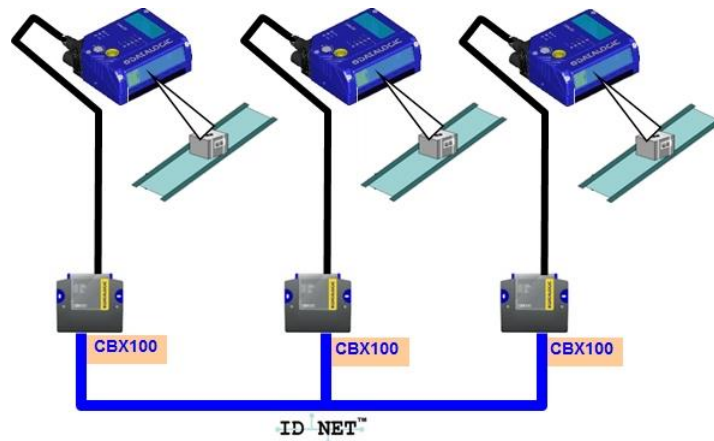

ID-NET interface allows connection of scanners reading objects placed on independent conveyors. All scanners are typically located far away from each other and they use a dedicated presence sensor.

At the end of each reading phase, each scanner transmits its own data message to the host.

Thanks to ID-NET, data collection among readers is accomplished at a high speed without the need of an external multiplexing device. This leads to an overall cost reduction and to a simple system wiring.

2.2.1 How To Setup/Configure the Scanner Network

A complete ID-NET scanner network can be rapidly setup, as follows:

Mounting & Connection

1. Mechanically mount/install all the readers (refer to par. 3.2 and 3.3).
2. Wire ID-NET (refer to par. 4.3).
3. Connect the planned Master scanner to a PC by means of the Genius configuration software.
4. Power up the entire system.

Configuration

1. Launch Genius.
2. From the Genius Device Menu select "Local Device Network Settings" and program the Role of the Master scanner (Synchronized or Multidata).

This procedure requires the Network Baud Rate be the same for all Slaves and Master, (500 kbs is the default value). It can be changed after network setup using Genius through the Master scanner. See also the alternative procedure in the note below.

3. At the prompt to "Send updated Network configuration to the Local Device" (Master) choose "Yes".
4. Then run the NET-AUTOSET procedure from the Icon in the Devices Area. Genius sets all slave scanners according to the Master Role (Synchronized or Multidata), and assigns each a random address. If necessary, this address can be changed through the Network Wizard.
5. Configure the System parameters via Genius.
6. If using the CBX connection box equipped with a BM100 Backup module, perform System Backup at the Master. See par. 2.4 of this manual or the BM100 or BM150 manuals for details.

The scanner network is ready.



NOTE: If necessary, the ID-NET baudrate can be set individually on each Slave scanner to match the Master. Connect each Slave to Genius and set the Reading System Layout > Network Baudrate parameter. Then follow the procedure above.



NOTE: An alternative method of programming scanner address and role assignment can be accomplished by using the "Connectivity Programming Barcodes" (refer to the "Setup Procedure Using Programming Barcodes" document on the downloadable Genius mini-DVD zip file.).

2.3 X-PRESS HUMAN MACHINE INTERFACE

X-PRESS is the intuitive Human Machine Interface designed with the precise goal of improving ease of installation and maintenance.

Status and diagnostic information are clearly presented by means of five-colored LEDs, whereas the single multi-function key gives immediate access to relevant functions:

- *Autosetup* to self-optimize reading performance in demanding applications
- *Autolearn* to self-detect unknown barcodes
- *Focus Lock* to memorize the mechanical focus position
- *Test Mode* with bar-graph visualization to check static reading performance

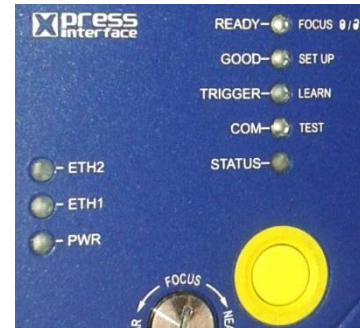

X-PRESS is the common interface adopted in all new products: *“You learn one, you can use them all”*.

The colors and meaning of the five LEDs when in the one of the operating modes (On-Line, Automatic or Continuous) are illustrated in par 2.1.1.



NOTE: Except for the Focus Lock/Unlock function, the X-PRESS functions do not work if the motor or laser are turned off, see chp. 8 for details.

2.3.1 Diagnostic Indication

The “STATUS” and “READY” LEDs blink simultaneously to signal the presence of an alarm or failure.

Diagnostic messages can be enabled to provide details about specific failure conditions. These messages will be shown on the display and if enabled for transmission, also on the selected interfaces. See par. 2.6 for details.

At the same time one or more LEDs light up according to the following scheme:

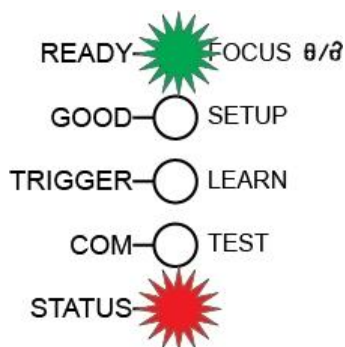

LED	STATUS
READY	BLINK
GOOD	ON to indicate any Failure different than Motor or Laser failures.
TRIGGER	ON to indicate a Motor Failure.
COM	ON to indicate a Laser Failure.
STATUS	BLINK

2.3.2 X-PRESS Functions

Quick access to the following functions is provided by an easy procedure using the push button:

- 1 – **Press** the button (the STATUS LED will give a visual feedback).
- 2 – **Hold** the button until the specific function LED is on (TEST, LEARN or SETUP).
- 3 – **Release** the button to enter the specific function.

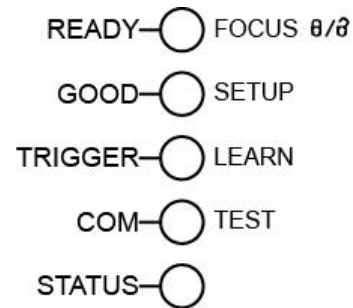

Once button is pressed, the cycle of LEDs activation is as follows:

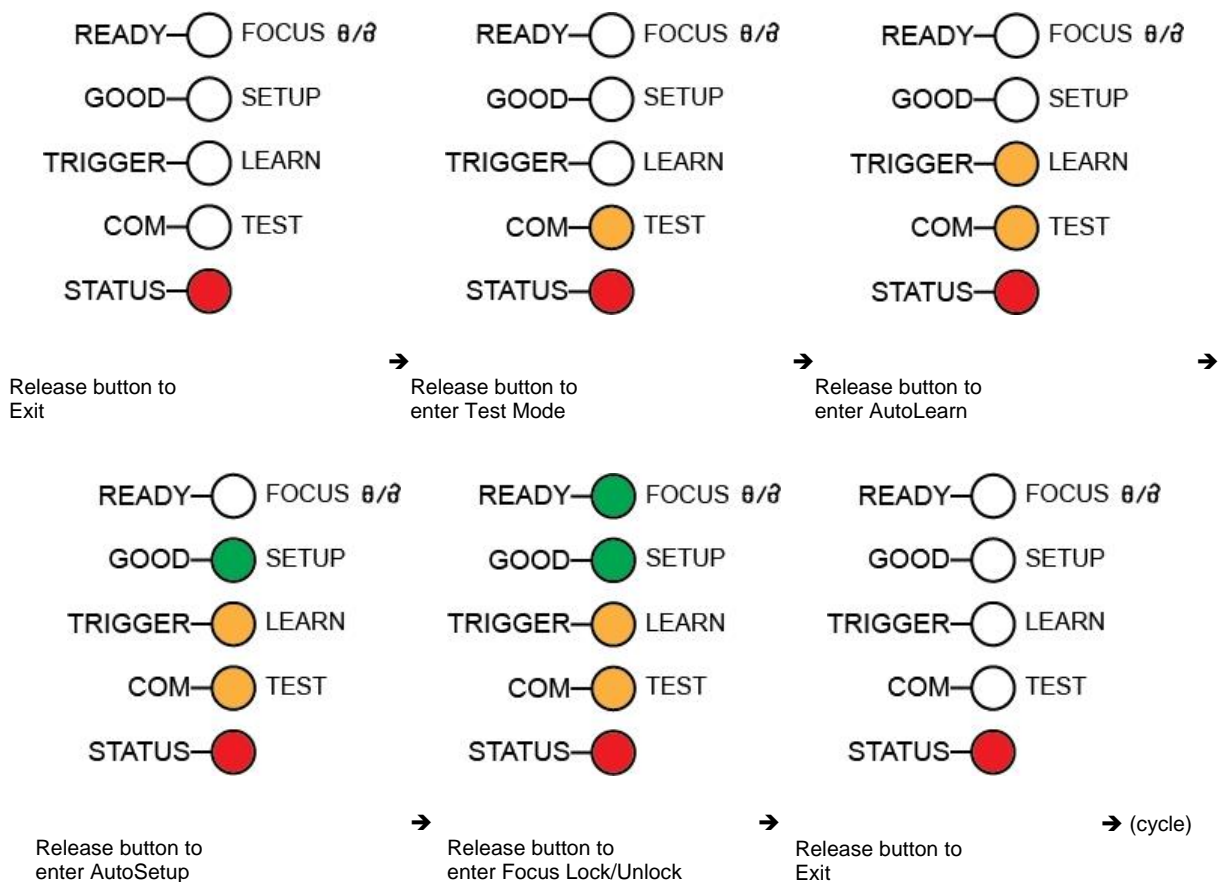

Test Mode Function

Once entered, the Bar-Graph on the five LEDs is activated and if the scanner starts reading barcodes the Bar-Graph shows the Good Read Rate. In case of no read condition, only the STATUS LED is on and blinks.

To exit the Test Mode, press the X-PRESS push button once.

AutoLearn Function

Once entered, the reader starts a procedure to automatically detect and recognize barcodes (by type and length), which are presented to it¹. The laser turns on and the LEARN LED blinks to indicate the ongoing process.

The procedure is as follows:

- **place** the desired barcode on the scanline.
- **wait** until the LEARN LED stays steady on (indicating the reader has detected the barcode).
- **repeat**, if needed, the above two steps to program up to 10 different barcodes (the LEARN LED returns to the blinking state for the next code). If more than one barcode is detected in the scan line, the Multi Label mode is enabled (refer to the “*5K Family Software Configuration Parameter Guide*” Help file).
- **exit** the process by pressing the X-PRESS push button once.

The scanner will restart at the end of the process, and then the detected barcodes are automatically configured in scanner memory.

AutoSetup Function

Once entered, if a barcode label is positioned in front of the scanline, the scanner automatically performs the optimal setup of the reading parameters for that specific barcode.

The procedure is as follows:

- **place** the desired barcode on the scanline.
- **enter** the *AutoSetup* function (the laser turns on and the SETUP LED blinks to indicate the ongoing process).
- **wait** until the SETUP LED stays steady on (indicating the reader has detected the barcode).

This procedure ends either when the barcode is successfully decoded or after a timeout of about 7 (seven) seconds.

The scanner will restart at the end of the process, and then the optimized reading parameters for that barcode are automatically configured in scanner memory.



NOTE: The AutoSetup function does not modify the programmed barcode symbologies. If needed, the AutoLearn function can be performed after Autosetup.

¹ In case of Programming Barcodes, refer to the “Setup Procedure Using Programming Barcodes” document on the downloadable Genius mini-DVD zip file.

Focus Lock/Unlock

Once entered, the scanner automatically performs the *Focus Lock* procedure to save the mechanical focus position to memory. If the mechanical focus position is changed by more than the allowed tolerance of the value in memory, a diagnostic alarm will be sent to the display.

The procedure is as follows:

- **enter** the Focus Lock function.
- **wait** until the "Focus locked at..." message appears on the display (indicating the focus position has been saved to memory). The following parameters are set:
 - Locked Position = your mechanical setting
 - Focus Displacement (Alarm) = set (default to display only)

If the Focus lock has already been set, this procedure can be used to Unlock the focus value. In this case control of the focus position is disabled.

The scanner will restart at the end of the process.

Reset Scanner to Factory Default

If it ever becomes necessary to reset the scanner to the factory default values, you can perform this procedure by holding the X-PRESS push button pressed while powering up the scanner and waiting for all LEDs to blink simultaneously three times before releasing the push button.

This procedure takes \approx 5-6 seconds for Serial Models, \approx 10 seconds for Ethernet Models, \approx 20 seconds for Profinet-IO models. At the end of the procedure the Configuration and Environmental parameters are reset and the message "Default Set" is shown on the scanner display. If connected through a CBX500 with display module, the "Default Set" message is also shown on the CBX500 display.

2.4 EXTERNAL MEMORY BACKUP & RESTORE

By selecting "External Memory Backup & Restore" from the Device menu, the following dialog box appears allowing Complete Configuration and Environmental parameter storage for network and reading devices.

Backup & Restore can be applied to any connected device through which backup memory is available, regardless of the devices' network configuration.

Backup & Restore automatically checks whether a previous backup or configuration is already stored in backup memory for each device, speeding up the procedure and making it more secure.

The Backup & Restore function is supported by the scanner when connected to or through:

- CBX + BM100 and/or BM2x0
- SC4000 ID-NET Controller
- QL500 (Ethernet TCP/IP)
- QLM-Series Gateways

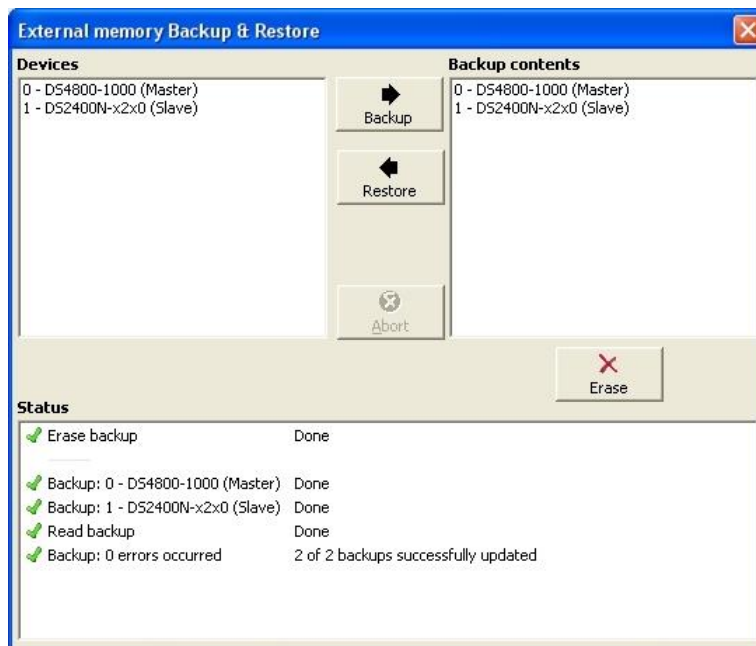
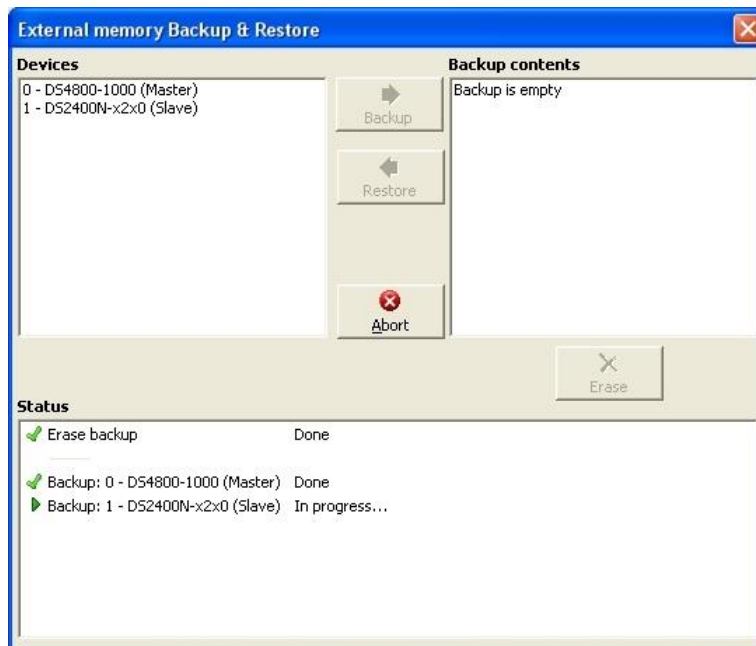

NOTE:

- Before executing a Backup on a BM100 backup module make sure the Write Protection switch is set to Unlocked.
- If BM100 and BM2x0 are both installed B&R is automatically performed only on the BM100 module.
- BM2x0 can execute B&R only with Network up and running (network cable connected).
- QL500 can backup up to 10 nodes (Master + 9 slaves).

In the pictures above, the Backup/Restore Dialog is shown:

- the **Devices** window lists all of the available devices in the current configuration,
- the **Backup Contents** window lists any previous device backups.

To perform a **Backup**:

1. Press the Backup button (you will be warned that all previous backups will be overwritten)
2. The Status window shows information as the backup procedure is being executed

To perform a **Restore**:

1. Press the Restore button (you will be warned that all scanner configurations will be overwritten)
2. The Status window shows information as the restore procedure is being executed

The **Restore** function also provides easy and secure Single Device Replacement:

1. Remove the scanner to be replaced
2. Connect the new scanner (make sure the new scanner has been previously set to default)
3. Run the Restore procedure by pressing the Restore Button (see: Restore procedure)



NOTE: If the Automatic Scanner Replacement parameter is enabled the Restore procedure starts automatically when the new scanner is recognized.

To **Erase** any previous Backup:

1. Press the Erase button
2. All backups are deleted

The **Status** window shows the status of the backup procedure as it is being executed.

The following is a list of possible error messages:

Module not present: backup module not mounted (BM100) or not ready (QL500 , BM2x0, SC4000, QLMxxx), or Search for Backup Memory at Device Startup parameter disabled

Unable to Read Backup State: Genius is unable to get connected to the device

Backup function not allowed: when device is in X-PRESS Menu mode (BM100) or is out of memory (QL500)

Failed! (Device not found): Master is unable to reach the addressed device

Failed! (Module is write protected): BM100 Write Protection switch is set to Locked

2.5 AUTOMATIC SCANNER REPLACEMENT

This parameter allows single scanner replacement to take place automatically (at power on time only) whenever a scanner substitution is made. Data for the Automatic Scanner Replacement are stored in the backup memory [BM100 Backup Module or QLMxxx Gateway]. To correctly activate the Automatic Scanner Replacement feature follow these steps:

Master/Slave Configuration:

1. Connect to the Master and properly configure all of the scanners in your system according to your application needs.
2. Enable the Automatic Scanner Replacement parameter on the Master, then Send the configuration to the Master.
3. Backup the complete network configuration by selecting Backup & Restore in the Device drop-down list from the Genius menu.
4. Get the Masters' configuration and verify that the Automatic Scanner Replacement parameter is enabled.

The Automatic Scanner Replacement is now enabled. If any network scanner (Master or Slave) is ever replaced by a new one (which must be set to the Default Configuration or have the proper node address) the Automatic Scanner Replacement feature will be performed.

Other Configuration:

1. Connect to the scanner and properly configure it according to your application needs.
2. Enable the Automatic Scanner Replacement parameter, then Send the configuration to the scanner.
3. Backup the configuration by selecting Backup & Restore in the Device drop-down list from the Genius menu.
4. Get the configuration and verify that the Automatic Scanner Replacement parameter is enabled.

The Automatic Scanner Replacement is now enabled. If the scanner is ever replaced by a new one (which must be set to the Default Configuration), the Automatic Scanner Replacement feature will be performed.

NOTE 1: The Automatic Scanner Replacement feature can only be performed at power up (either Master or Other: Stand Alone) and only one scanner at a time can be replaced.

NOTE 2: Once the Automatic Scanner Replacement has been activated, the Restore feature is also available.

NOTE 3: Once the Automatic Scanner Replacement has been activated, it will be forced if a "Reset Scanner to Factory Default" procedure is performed (by pressing and holding the X-PRESS button at power-up).

NOTE 4: Once the Automatic Scanner Replacement has been activated, it can be disabled only by Erasing the Backup content from the backup memory or by backing up a configuration once the Automatic Scanner Replacement parameter has been disabled.

2.6 DISPLAY

The DS5100 is equipped with a 2 line by 16 character LCD display which shows various diagnostic, menu and operating mode messages according to a defined priority (0 = top priority):

Priority	Message Type
0:	File Transfer, Backup & Restore, Restore Default Parameters
1:	X-PRESS Menu Selection
2:	Focus Setup Procedure
3:	Diagnostic Alarms *
4:	Reading Results
5:	Welcome Message ²

* Diagnostic Alarm Messages can be enabled/disabled in Genius.

The display language for messages can be selected in Genius. The currently supported languages are:

- English (default)
- French
- German
- Italian
- Japanese

2.6.1 Display Messages

The following examples of DS5100 Local Display messages are given to help interpret the information reported.

Test Mode Results:

```
A A A % Z Z Z Z Z Z Z Z Z Z Z Z Z
F = X X X c m - Y Y . Y i n
```

A = reading percentage from 000 to 100%.

Z = code content.

F = focus distance in given in centimetres and inches.

² For Master devices only, Network Diagnostics can be enabled through the Network Status Monitor parameter in Genius instead of the Welcome Message.

Autolearn Results:

```
X X X X X X X X X X      Y Y D G T
A u t o l e a r n      O k      # Z Z
```

X = recognized code symbology.

Y = number of digits in the read code

Z = number of configured slot (at the end of the procedure this number represents the total slots configured).

Diagnostic Alarms:

```
A l e r t      : F o c u s
E x p = X X X c m - X X . X i n
```

X = expected focus distance in cm and inches

```
A l e r t      : M o t o r
S p e e d      = X X X X / Y Y Y Y
```

X = expected speed

Y = actual speed

Generic Alarms:

```
A l e r t      :
F a i l u r e      # X X X
```

X = numeric error value (even if User Defined Messages are selected for data transmission the numeric error value is sent to the display)

Slave Node Alarms:

```
A l e r t      : I D - N E T
N o d e # X X      F a i l # Y Y Y
```

X = slave node number (1-31)

Y = numeric error value

Reading Results:

```

A A A A X X X X X X X X X X X X
Y Y C o d e s

```

A = reading result – Good (Good Read), Part (Partial Read), Mult (Multiple Read)

X = code content

Y = number of codes read

```

G o o d X X X X X X X X X X X X
Y Y D G T D W W W S S S

```

X = code content

Y = number of digits in the code

DGT = "digits"

D = code direction – F=forward, R=reverse, U=unknown

Linear Reading (only if the Quality Counters parameter is enabled)

W = number of scans on the code

S = Quality Counters value (max 100)

Code Reconstruction

W = number of scans on the code (max 255)

S = number of decodes (max 255), on the digit in the code which was decoded the least number of times

Network Diagnostic Messages (Master only):

The display alternates between message 1 and 2.

Message 1

```

0 N e t w o r k 1 5
M S S S S S S S S S S S S S S

```

Message 2

```

1 6 N e t w o r k 3 1
S S S S S S S S S S S S S S S

```

M = Master diagnostic condition; S = Slave diagnostic condition:

* = scanner OK

- =scanner not detected at startup

? =scanner detected at startup but not responding to diagnostic polling

! = scanner diagnostic error

Welcome Message:

The display alternates between message 1, 2 and 3.

Message 1 X X X X X X X X X X X X X R R R
K K K Y Y Y Y Y Y Y Y Y Y Y N N N

X = scanner model
 K = software – STD=Standard, SS=Special
 Y = software version
 R = Device Network Type – MUL=Multidata, SYN=Synchronized, ALN=Alone



NOTE: For dual port Profinet-IO/EBC models, R = Operating Mode – ONL=On Line, AUT=Automatic, CON=Continuous, TST=Test, PKT=PackTrack (EBC only).

N = Device Network Setting – M00=ID-NET Network Master, Sxx= ID-NET Network Slave address or EBC Slave address, Null string= Alone (no network)

Focus Locked:

Message 2 F o c u s L o c k e d a t
F = Z Z Z c m - Y Y . Y i n

X = device serial number
 Z = focus position in cm
 Y = focus position in inches

Focus Unlocked:

If focus is not locked an additional message “Please Lock Focus!” appears as well as the following:

Message 2 S N X X X X X X X X X X
F = Z Z Z c m - Y Y . Y i n

X = device serial number
 Z = focus position in cm
 Y = focus position in inches

Message 3 X X X X X X X X X X X X X X X
Y Y Y Y Y Y Y Y Y Y Y Y Y Y Y

X = connection type – Ethernet TCP/IP, Profinet-IO, EBC
 Y = IP address

2.7 MODEL DESCRIPTION

DS5100 scanners are described by their model number which indicates the characteristics listed in the diagram below. Not all combinations are available. For a complete list of combinations see the Models tab on the Product page of the website.

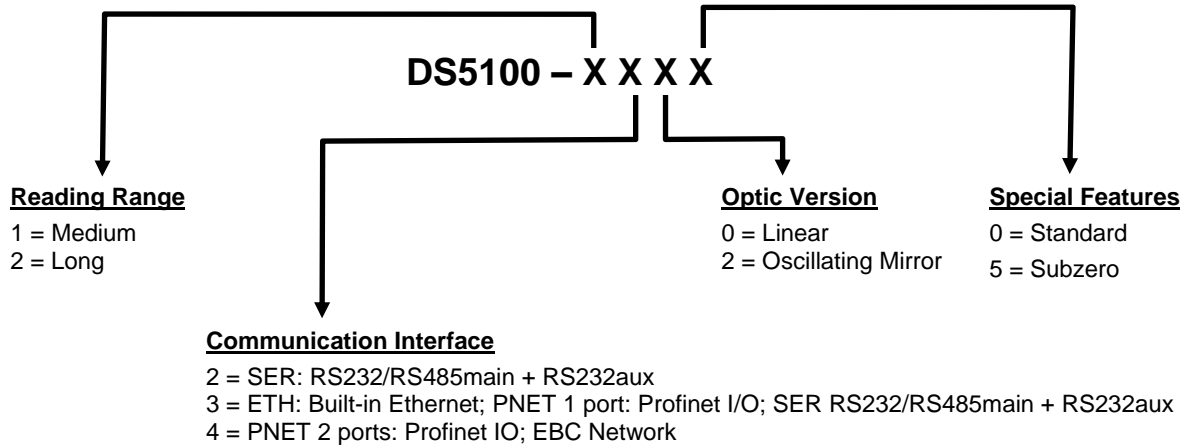

2.8 OSCILLATING MIRROR MODELS

The DS5100 OM is completely software controlled and software programmable through Genius which allows adjusting the oscillating frequency and the minimum and maximum oscillation angles of two separate reading zones.

When the oscillating mirror is programmed to read barcode labels at small angles, position the reader to **assure at least 15°** for the Skew angle. This angle refers to the most inclined or external laser line, so that all other laser lines assure more than 15° Skew. This avoids the direct reflection of the laser light emitted by the reader.

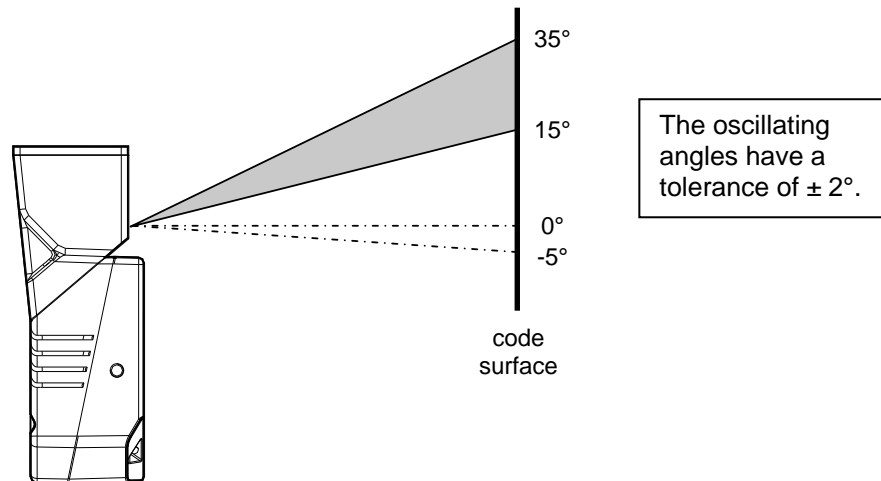

Figure 5 – Oscillating Mirror Skew Angle

Otherwise, the scanner can be mounted at an angle of inclination of 15° in order to attain symmetrical deflection ranges.

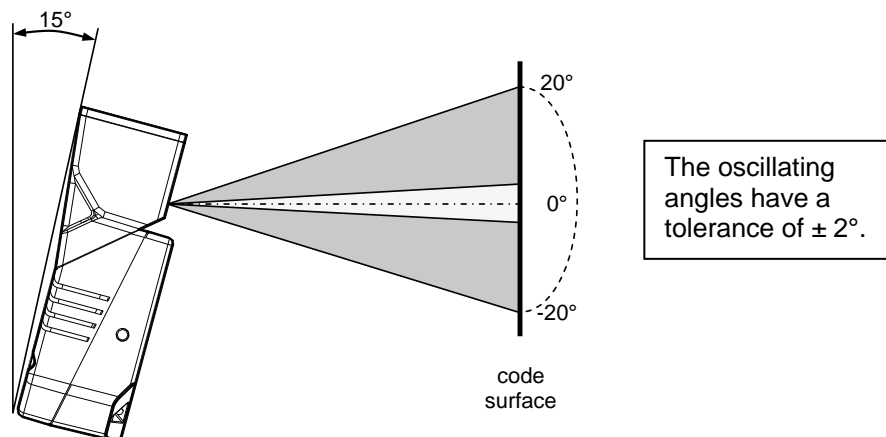

Figure 6 - Oscillating Mirror Reading Position

In the above case, the zone where the scan line is perpendicular to the reflecting surface corresponds to a neutral zone at the center of the reading field.



NOTE: By limiting the raster width to the minimum necessary, the number of scans on the reading surface is increased.

2.9 SUBZERO TEMPERATURE MODELS

The DS5100 Subzero scanner is an industrial scanner designed to operate in industrial refrigerator/freezer cells or other stable subzero degree environments, which are below the operating range of standard industrial scanners. It is not designed to move between subzero and normal environments (rapid temperature changes).

The DS5100 Subzero has an intelligent microprocessor-driven and efficient internal heating system which constantly monitors and automatically controls internal temperature. Only the necessary temperature-sensitive components are heated, resulting in an efficient heating system which has very low power consumption. Part of this system also heats the Laser Beam Output window to eliminate ice and/or condensation build-up from negatively affecting the reading results.

Upon power-up in a subzero environment, the scanner waits until these internal components are heated to within their operating temperature range. Power-up at $-35\text{ }^{\circ}\text{C}$ can take about 20 minutes before the scanner is ready to read barcodes. During this time the laser, motor, and display remain off and the Ready LED blinks, indicating the warm-up phase. While in the warm-up phase, scanner communication is operative and the device can be configured through Genius or through Host Mode Programming.

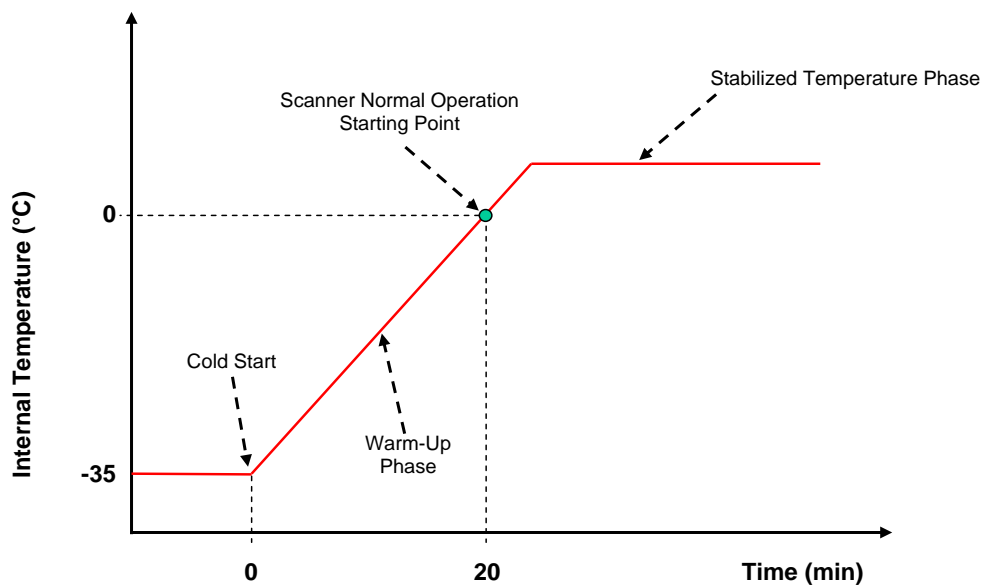

The DS5100 Subzero can be connected to the CBX100 LT Subzero connection box which can withstand the same low temperature environment as the scanner. A CBX100 LT all-in-one model includes a BM100 backup and restore module having an extended temperature range also for use in subzero environments.

2.10 IP ADDRESS ALIGNMENT USING GENIUS DISCOVERY

For Built-in Ethernet and Profinet-IO models, the scanner IP address can automatically be found on the Ethernet network by using the Genius Discovery utility available in the Options>Communications tab.



NOTE: This feature only works for the **built-in** interfaces: Ethernet or Profinet-IO.

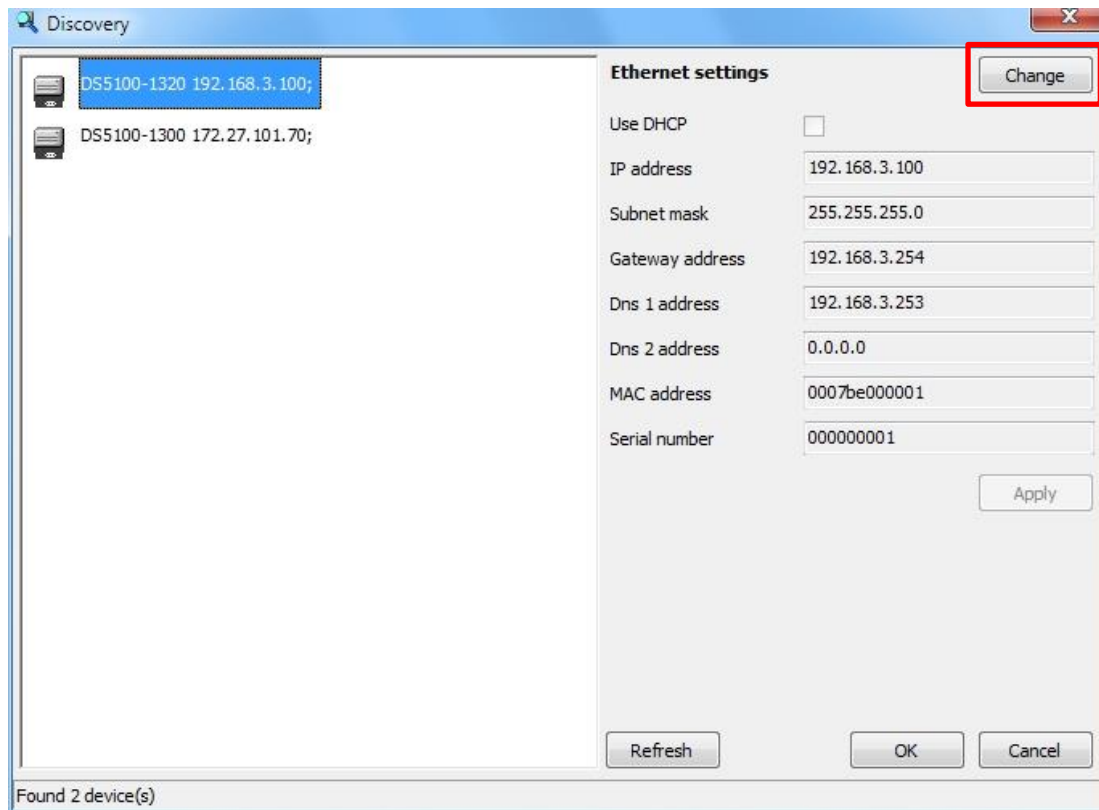

Discovery Procedure:

1. Select the desired device by comparing the MAC address and/or Serial Number fields with the label on the device.
2. Click the Change button to assign the desired IP address.



NOTE: It is advised to use an assigned static IP address instead of DHCP.

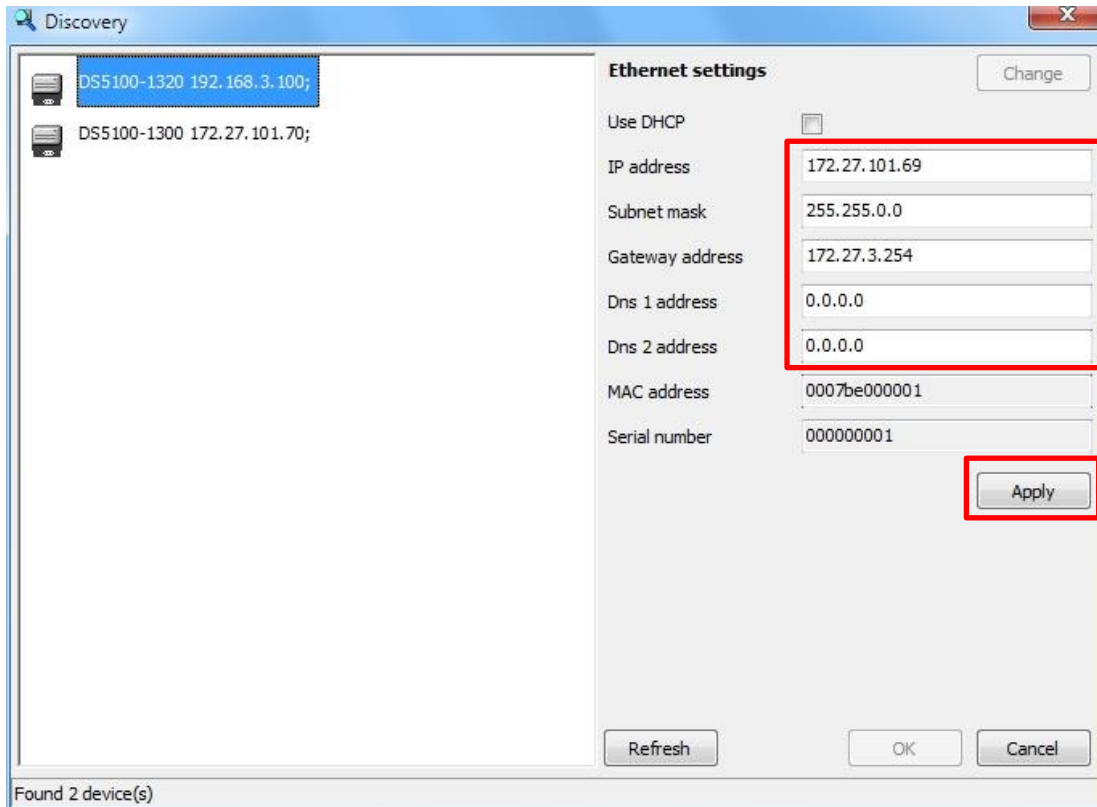

3. Click the Apply button. The device will be re-discovered. You should now see the device displayed with the newly assigned IP address.

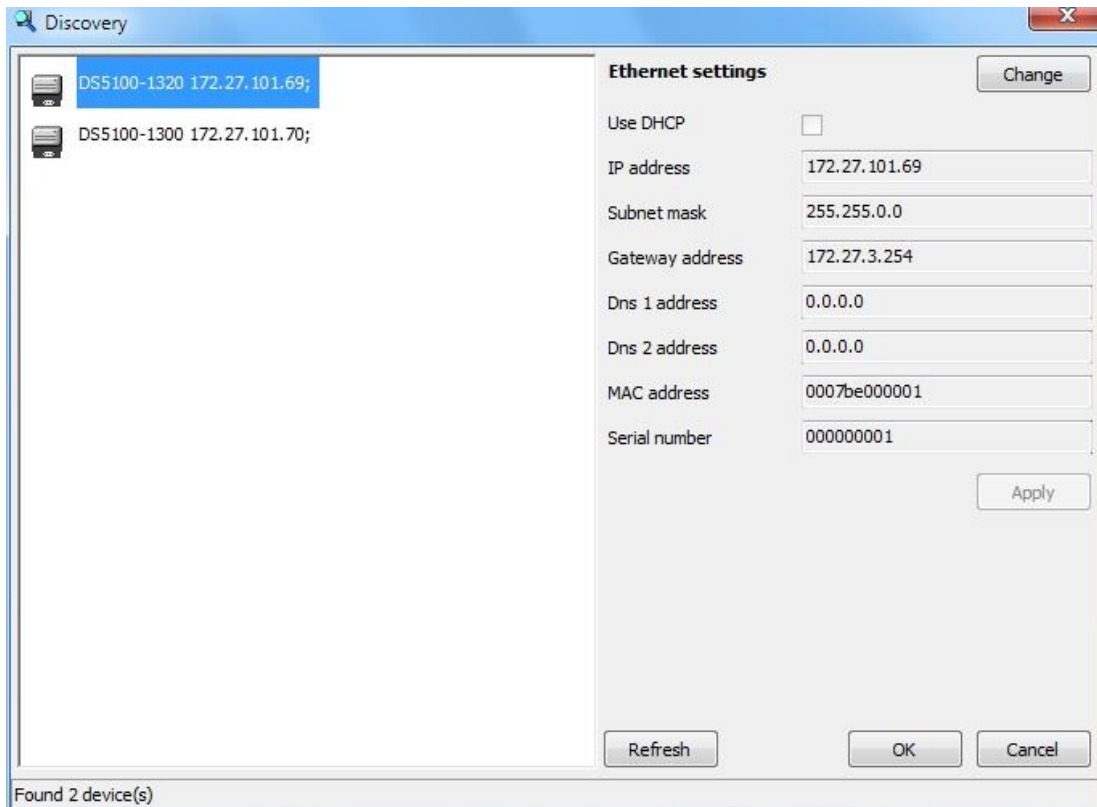

- Click OK to return to the Communications folder. You will see the updated IP address in the "Device address or name" field.



NOTE: The Port number used to connect to Genius **must** be 51235 (default).

- Click OK to return to Genius and perform a Device>Get to connect to the device.

2.11 ACCESSORIES

The following accessories are available on request for the DS5100:

Name	Description	Part Number
Mirrors		
GFC-40	105° Deflection Mirror (only for DS5100-XX00 Linear readers)	93ACC1785
GFC-400	(only for DS5100-XX00 Linear readers)	93ACC1867
Brackets		
BK-4000	L-Shape Bracket	93ACC1837
BK-4001	U-Shape Bracket	93ACC1838
Connection Boxes		
CBX100	Compact Connection Box	93A301067
CBX100 All-In-One	Compact Connection Box + BM100	93A301076
CBX100 LT	Compact Connection Box Subzero	93A301069
CBX100 LT All-In-One	Compact Connection Box Subzero + BM100	93A301085
CBX500	Modular Connection Box	93A301068
BM100	Backup Module	93ACC1808
BM150	CBX500 Display Module	93ACC1809
BM200/210	Ethernet TCP/IP Module STD/IP65	93ACC1851, 93ACC1852
BM300/310	Profibus Module STD/IP65	93ACC1810, 93ACC1811

Name	Description	Part Number
BM400	DeviceNet Module IP65	93ACC1814
BM500/510/520	Ethernet/IP Module STD/IP65/IP54	93ACC1812, 93ACC1813, 93ACC1840
BM600	CANopen Module	93ACC1815
BM700	Profinet Module	93ACC1816
BM1100	CC-Link Module	93ACC1845
BM1200/1210	Modbus TCP Module	93ACC1848, 93ACC1849
BM1300	EtherCAT IP54 Module	93ACC0113
BA100	DIN Rail Mounting Adapters	93ACC1821
BA200	Bosch and 80/20 Frame Mounting Adapters	93ACC1822
BA900	Two Cable Glands Panel	93ACC1847
QL100	Quick Link Slave ID-NET T-Connector	93ACC1860
QL150	Quick Link Slave ID-NET + Service T-Connector	93ACC1868
QL200	Quick Link Slave ID-NET + Power T-Connector	93ACC1861
QL300	Quick Link Master ID-NET Serial Host Connector	93ACC1862
QL500	Quick Link Master ID-NET Ethernet Host Connector (includes Ethernet/IP explicit messaging)	93ACC1864
QLM500	Quick Link Metal Master ID-NET - Ethernet/IP Gateway	93ACC0037
QLM600	Quick Link Metal Master ID-NET - Profibus Gateway	93ACC0033
QLM700	Quick Link Metal Master ID-NET - Profinet I/O Gateway	93ACC0038
Controllers		
SC4000-1000	ID-NET Standard Controller	935201000
SC5000-1000	Standard System Controller	935750001
SC5000-1100	Profibus System Controller	935750002
SC5000-1200	Profinet System Controller	935750003
Cables		
CAB-DS01-S	M12-IP67 Cable To CBX or QL (1M)	93A050058
CAB-DS03-S	M12-IP67 Cable To CBX or QL (3M)	93A050059
CAB-DS05-S	M12-IP67 Cable To CBX or QL (5M)	93A050060
CAB-XB02	25PM-25PF Extension Cable CBX (2M)	93A051384
CAB-ETH-M01	M12-RJ45 IP67 Ethernet Cable (1M)	93A051346
CAB-ETH-M03	M12-RJ45 IP67 Ethernet Cable (3M)	93A051347
CAB-ETH-M05	M12-RJ45 IP67 Ethernet Cable (5M)	93A051348
CBL-1534.02	Adapter Cable Ethernet M12 to RJ45	93A050057
ETH CABLE M12-M12 1M	M12-M12 Ethernet Cable (1M) for Profinet models	93A050065
ETH CABLE M12-M12 3M	M12-M12 Ethernet Cable (3M) for Profinet models	93A050066
ETH CABLE M12-M12 5M	M12-M12 Ethernet Cable (5M) for Profinet models	93A050067
CS-A1-02-G-03	M12 4PF-Wires Power Cable (3M) for Profinet models	95A251380
CS-A1-02-O-10	M12 4PF-Wires Power Cable (10M) for Profinet models	95A251090
AS-I Power Backbone	PWR Cable, AS-I, 2 Wires, 10M	93ACC0081
AS-I Power Backbone	PWR Cable, AS-I, 2 Wires, 25M	93ACC0082
AS-I Power Branch	PWR Cable M12- ASI standard-1M	93ACC0067
AS-I Power Branch	PWR Cable M12- ASI standard-2M	93ACC0068
Sensors		
MEP-593	Photocell Kit - PNP (PH-1)	93ACC1791
MEP-543	Photocell Kit - NPN	93ACC1728
Power Supplies		
PG-6000	24 V Power Supply Unit EU (for Serial and Ethernet models – connects to CBX)	93ACC1720

Name	Description	Part Number
PG-6001	24 V Power Supply Unit UK (for Serial and Ethernet models – connects to CBX)	93ACC1719
PG-6002	24 V Power Supply Unit US (for Serial and Ethernet models – connects to CBX)	93ACC1718
PG-100-K01	POWER SUPPLY 60W KIT EU with M12 connector (for Profinet models)	93ACC0059
PG-100-K02	POWER SUPPLY 60W KIT UK with M12 connector (for Profinet models)	93ACC0060
PG-100-K03	POWER SUPPLY 60W KIT US with M12 connector (for Profinet models)	93ACC0058
PG-240-K01	POWER SUPPLY 240W 8 Port M12 (EU) w/o M12 Cable	93ACC0145
PG-240-K03	POWER SUPPLY 240W 8 Port M12 (US) w/o M12 Cable	93ACC0144
PWR-480B	POWER UNIT 110/230VAC 24V	93ACC0076

3 MECHANICAL INSTALLATION

3.1 PACKAGE CONTENTS

Verify that the DS5100 reader and all the parts supplied with the equipment are present and intact when opening the packaging; the list of parts includes:

- DS5100 reader
- DS5100 Quick Guide
- Barcode Test Chart (Grade A)
- Mounting Kit:
 - bracket
 - screws
 - flat washers
 - lock washers

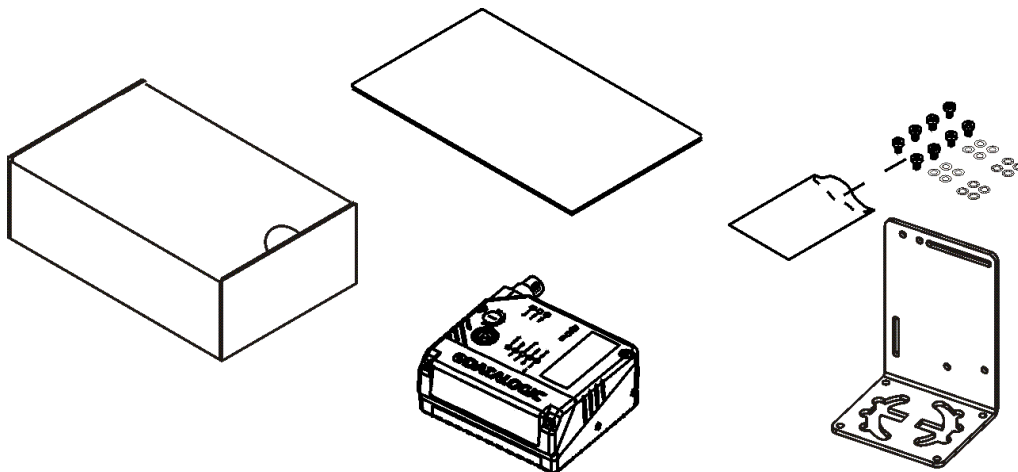

Figure 14- DS5100 Package Contents

3.2 MECHANICAL INSTALLATION

DS5100 can be installed to operate in different positions. The four screw holes (M4 x 5mm depth) on the body of the reader are for mechanical fixture to the L-shaped mounting bracket.

There are also three screw holes (M5 x 5mm depth) for fixture to the U-shaped mounting bracket.

The following diagrams give the overall dimensions of the scanner and mounting brackets and may be used for installation. Refer to par. 3.2.1 and 3.4 for correct positioning.

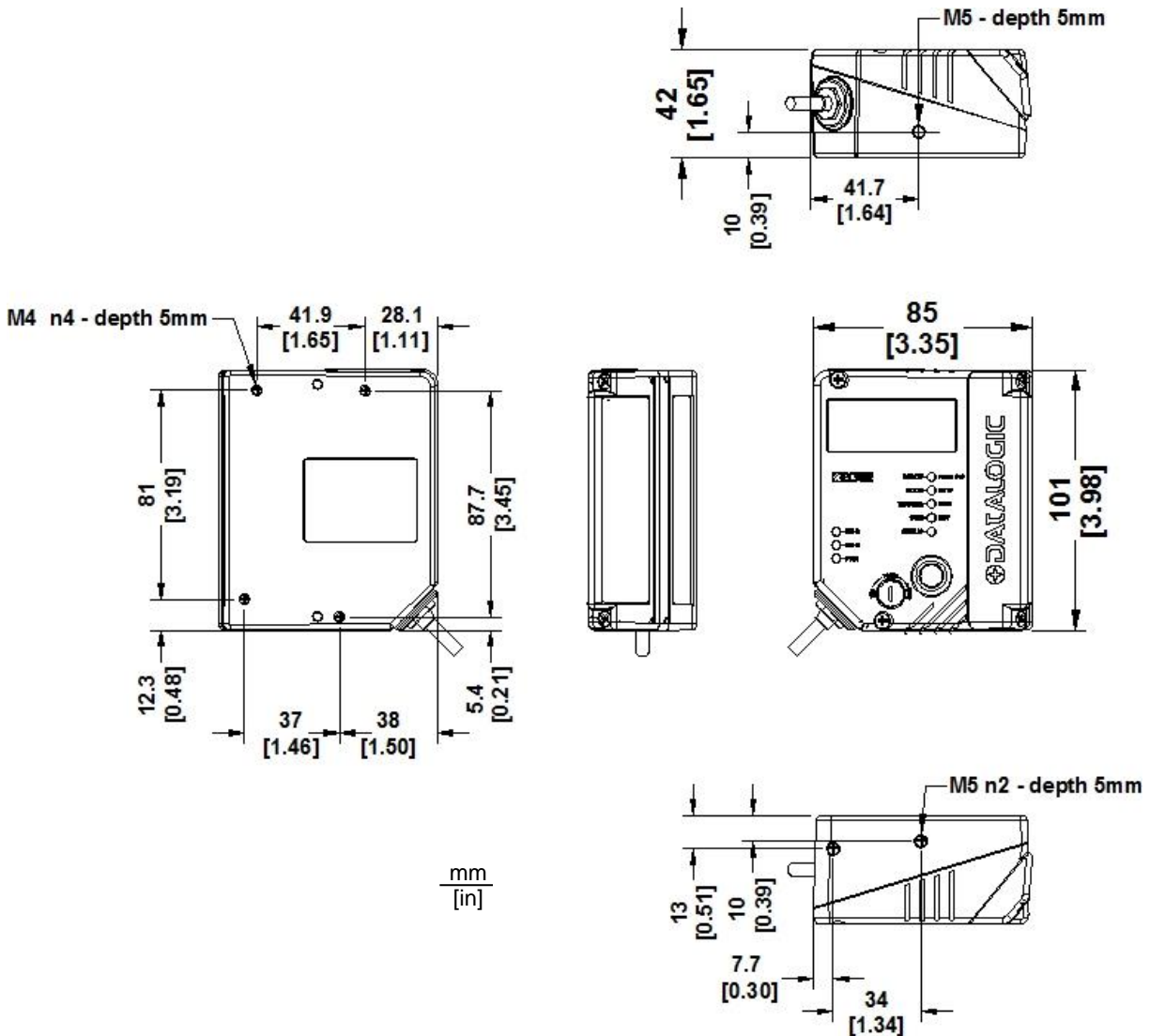
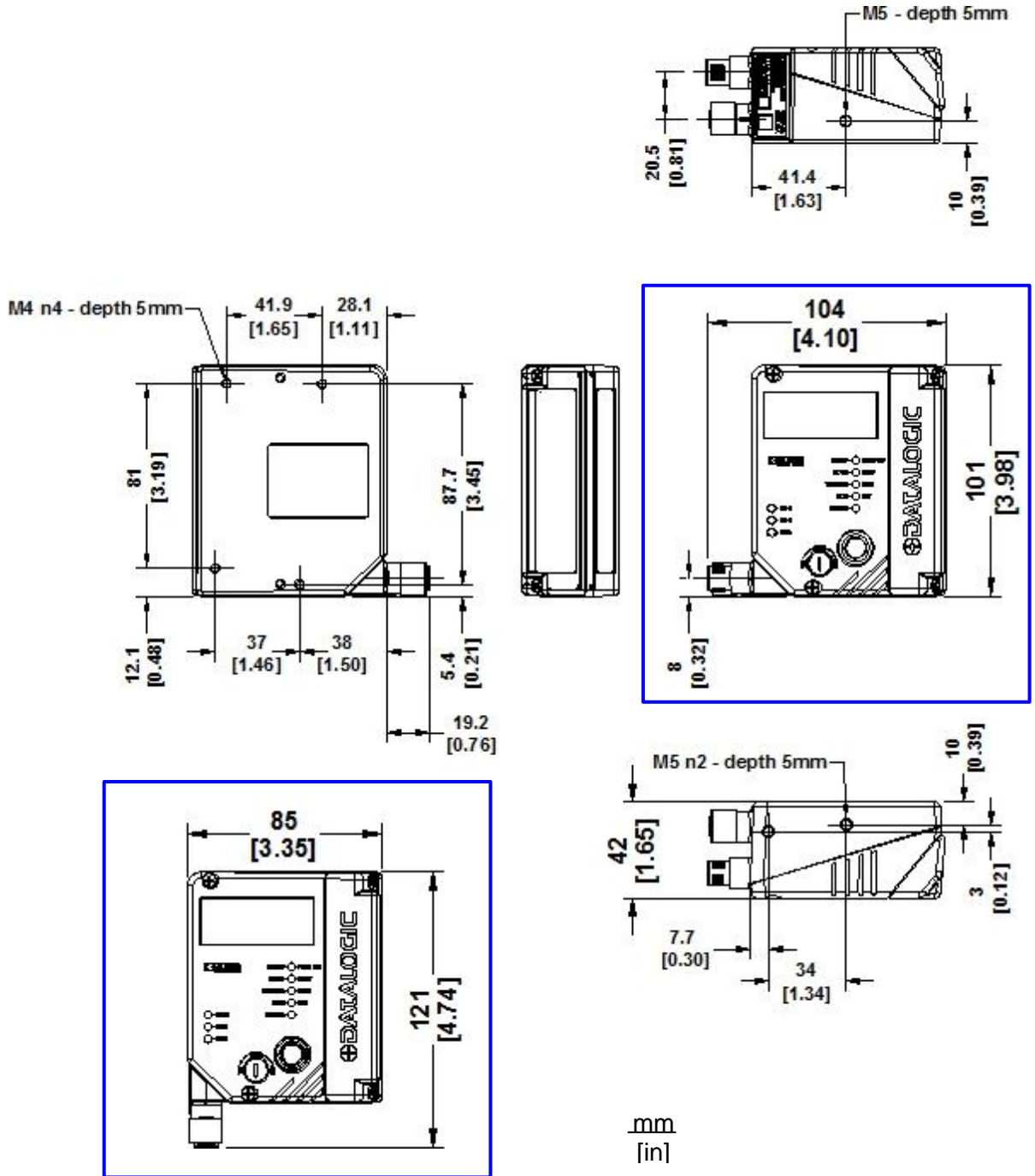
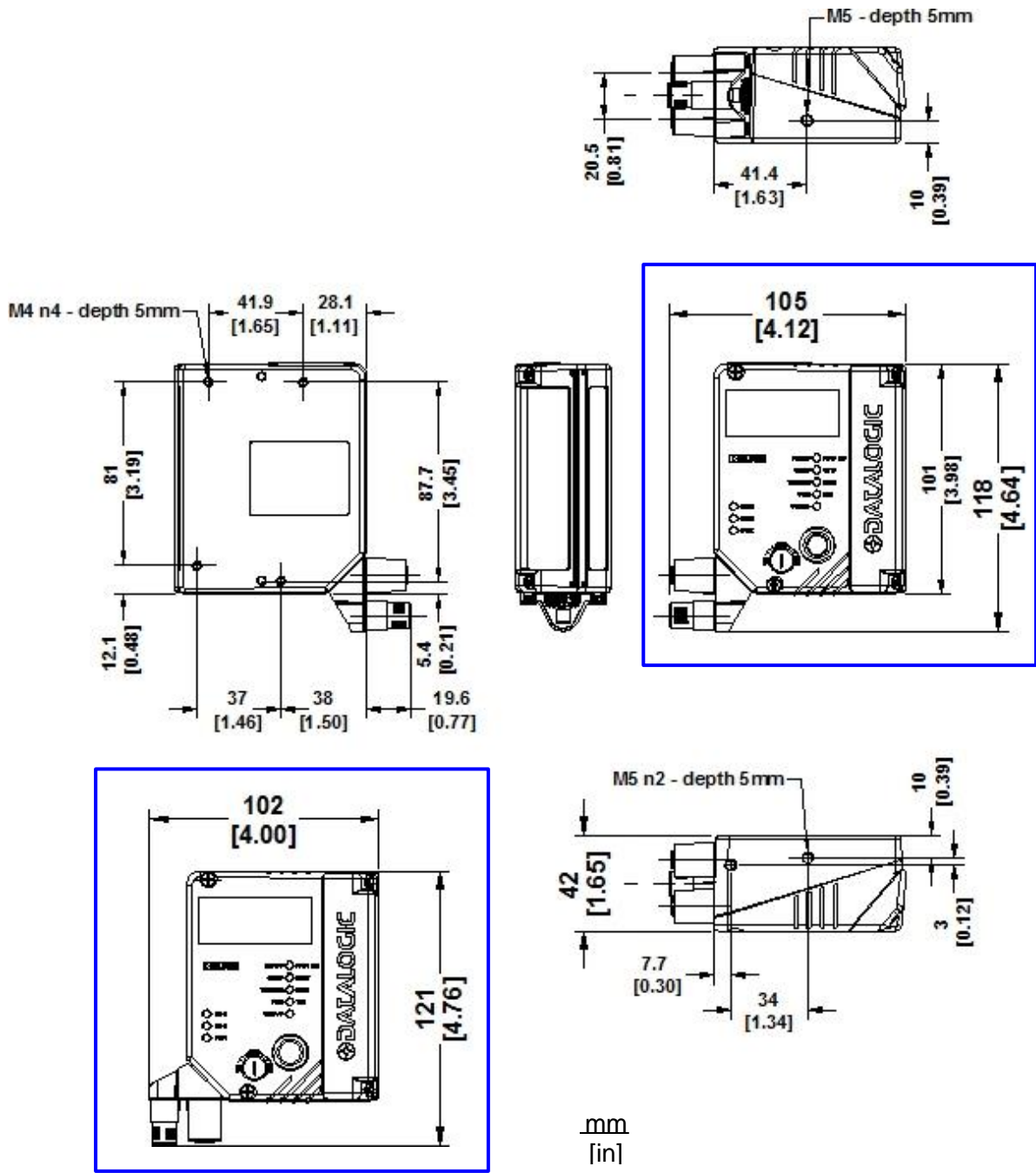

Figure 15 – DS5100 Standard Serial Model Overall Dimensions



Connector block rotates to 90° position.

Figure 16 – DS5100 Standard Ethernet Model Overall Dimensions



Connector block rotates to 90° position.

Figure 17 – DS5100 Standard Profinet Model Overall Dimensions

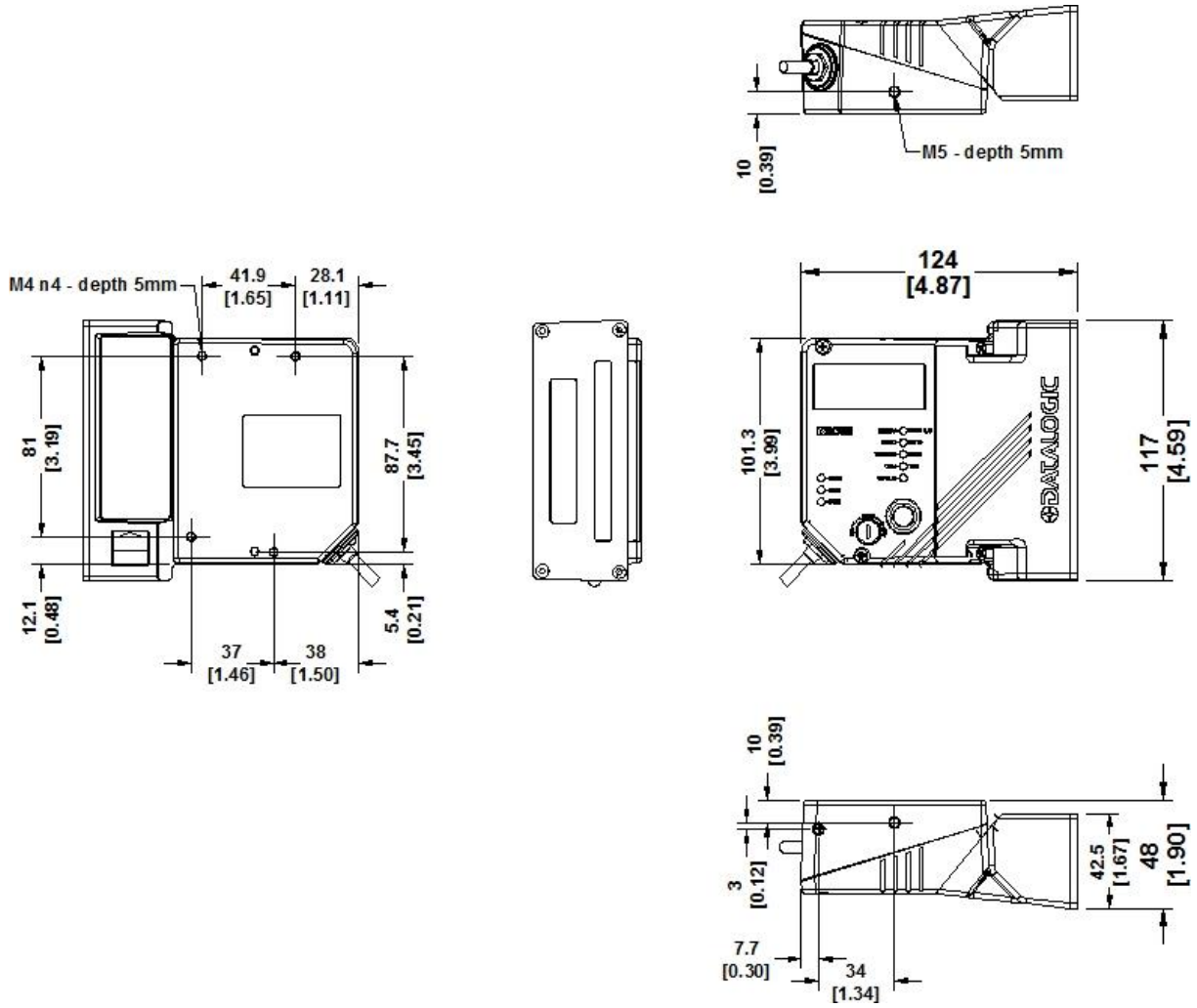
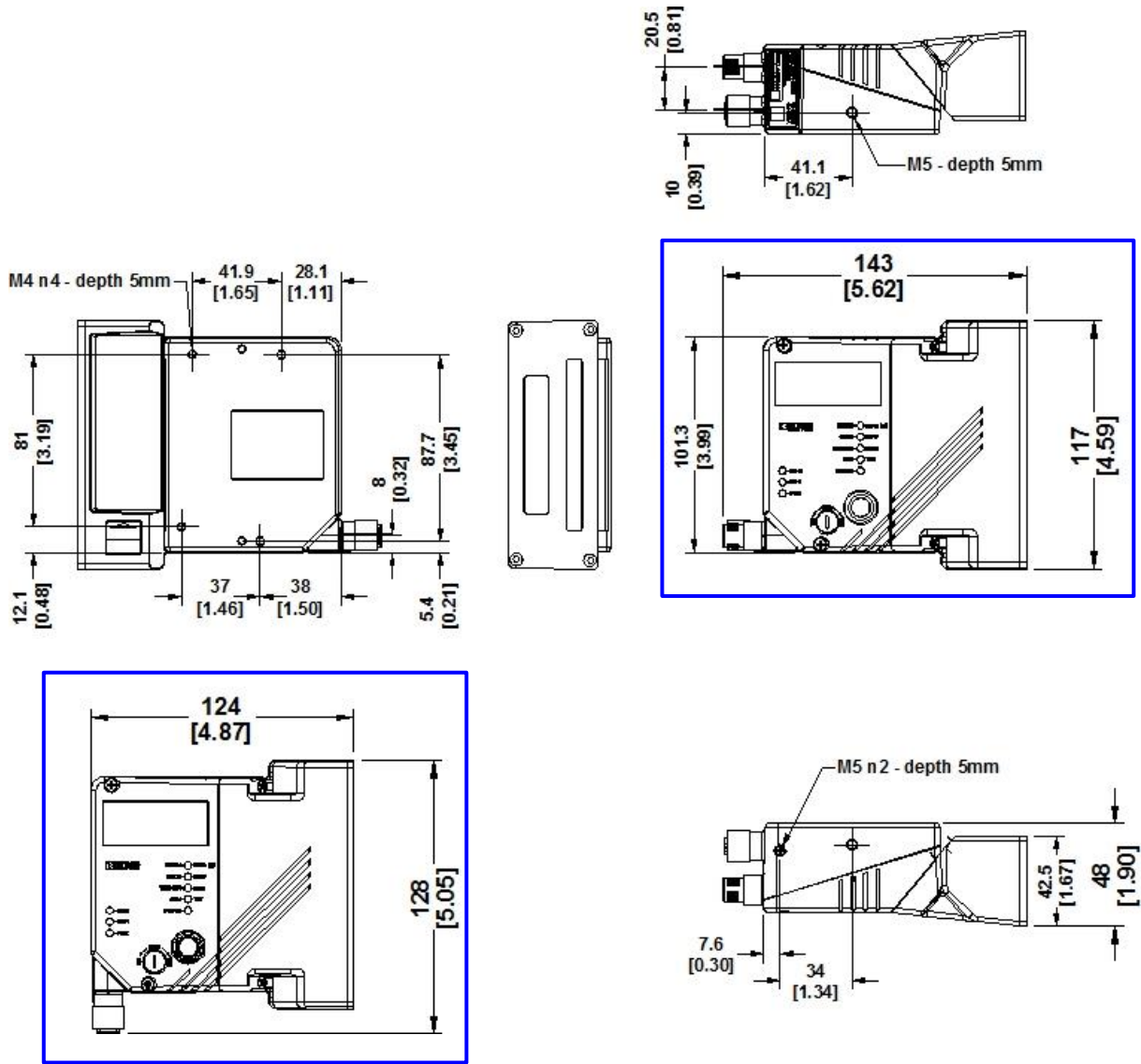
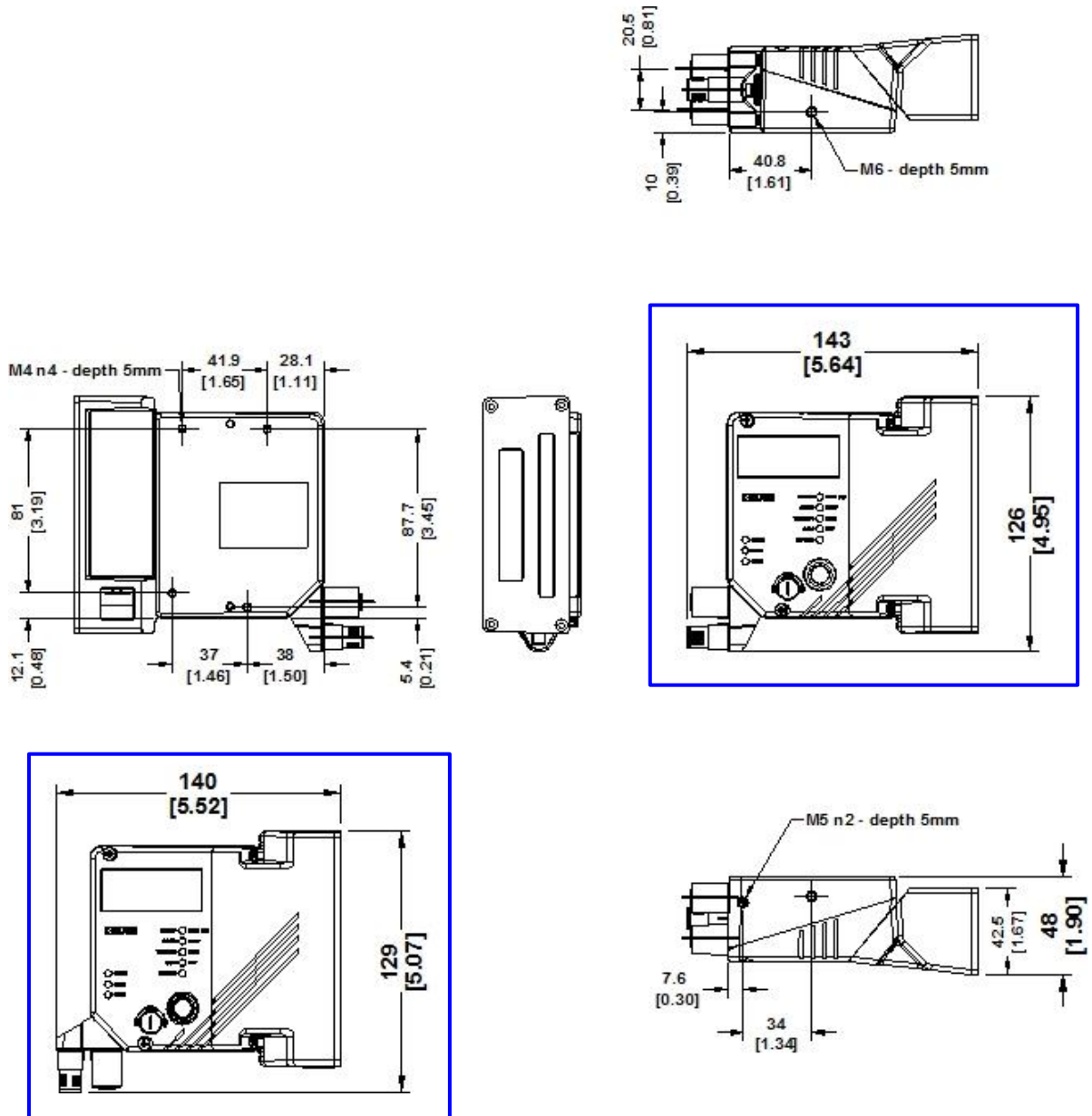

Figure 18 – DS5100 OM Serial Model Overall Dimensions



Connector block rotates to 90° position.

Figure 19 – DS5100 OM Ethernet Model Overall Dimensions



Connector block rotates to 90° position.

Figure 20 – DS5100 OM Profinet Model Overall Dimensions

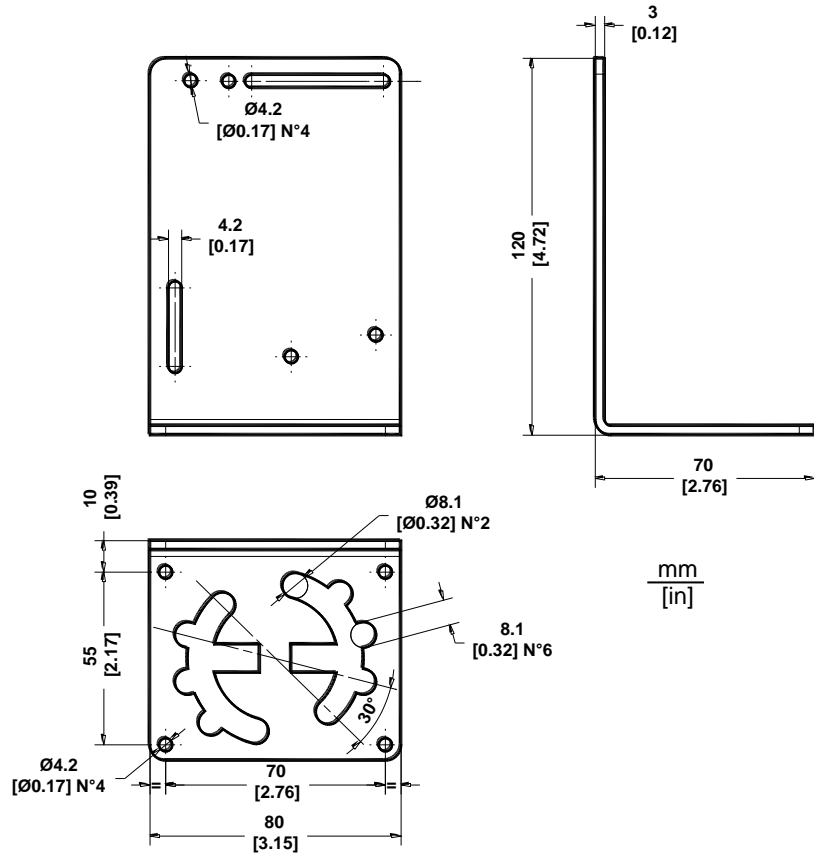

Figure 21 – L Shape Mounting Bracket Overall Dimensions

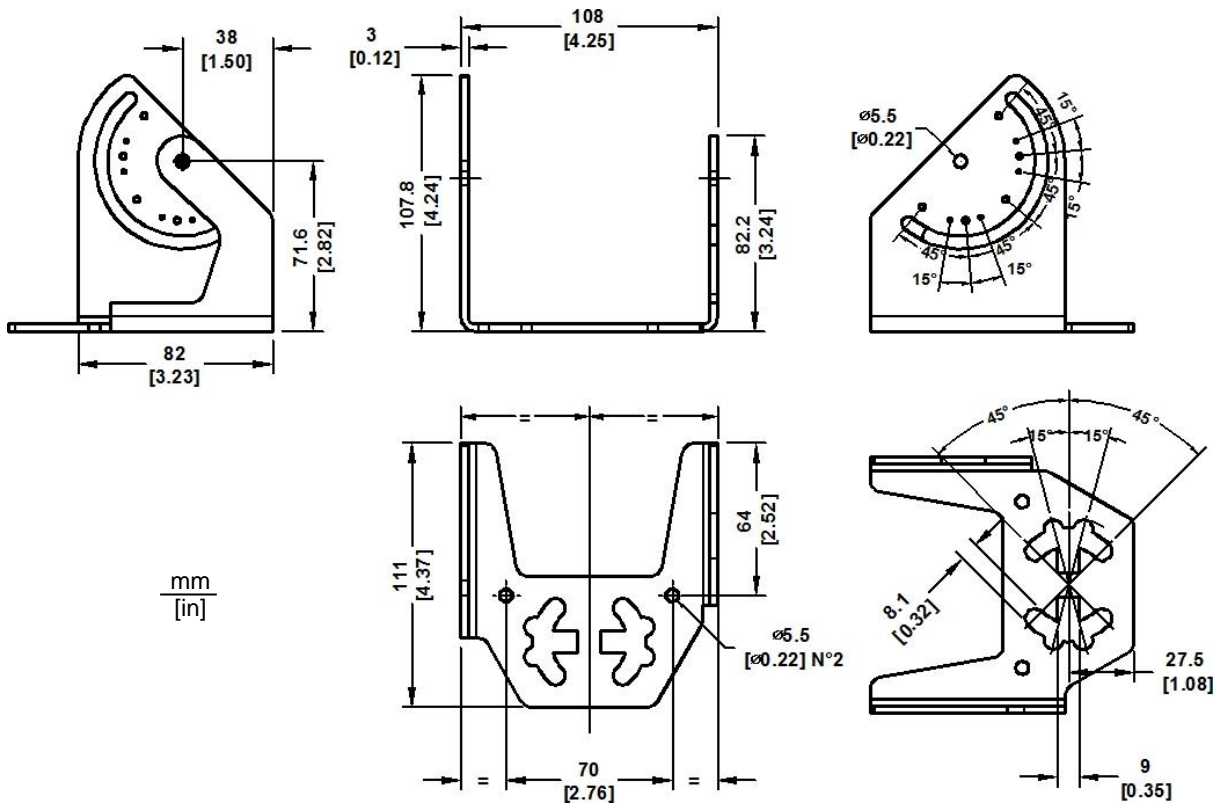

Figure 22 – U Shape Mounting Bracket Overall Dimensions

3.2.1 Mounting DS5100

Using the DS5100 mounting bracket you can quickly and easily obtain standard mounting positions (i.e. 15° Skew angles) for the reader as shown in the following figures:

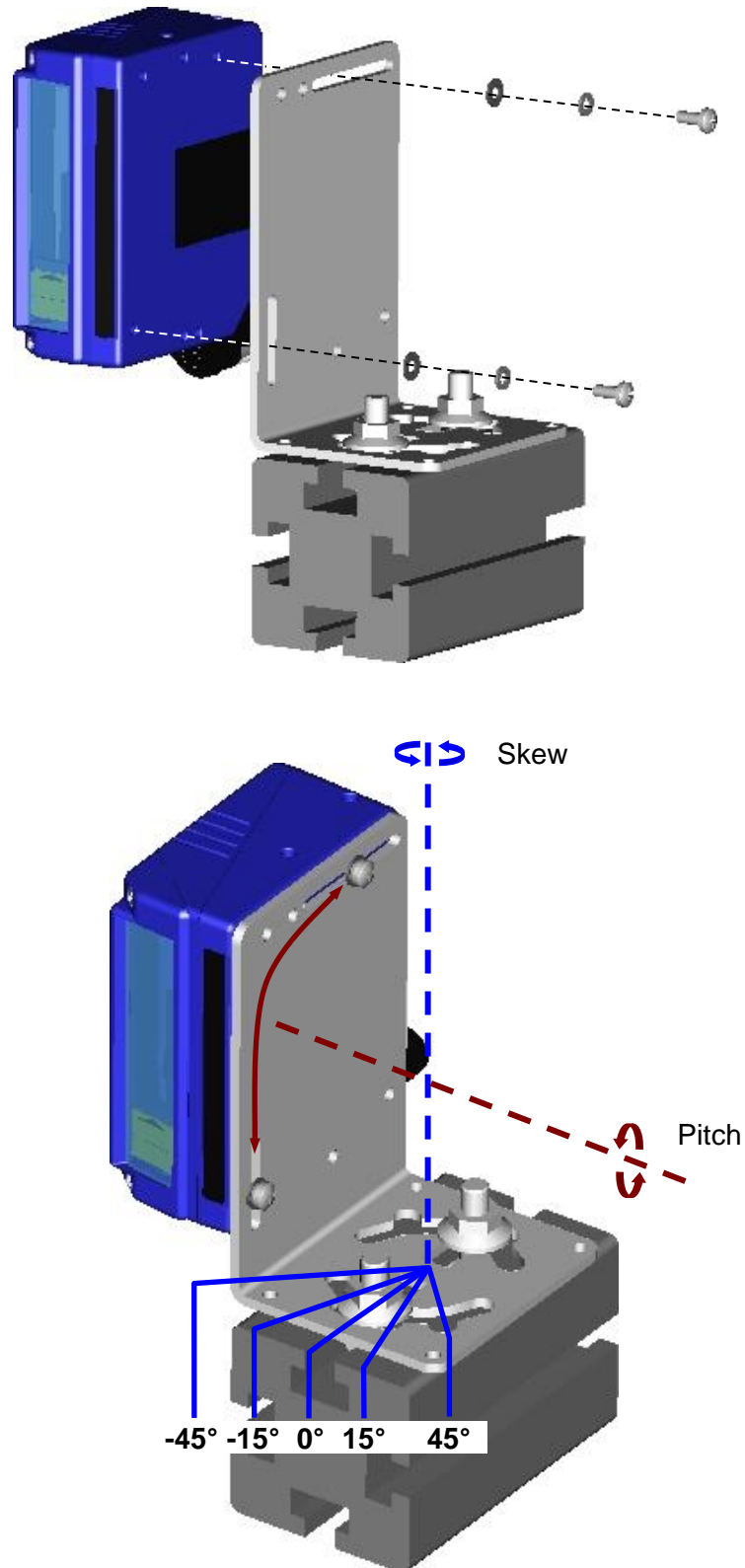

Figure 23 – Positioning with L Shape Mounting Bracket

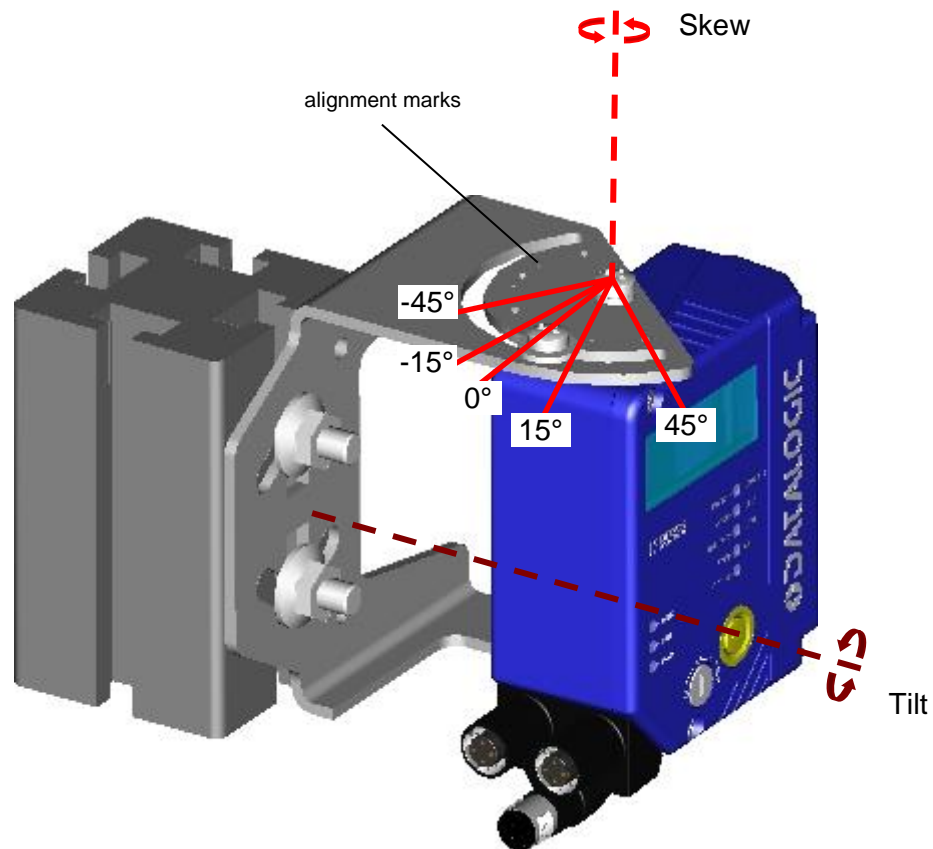
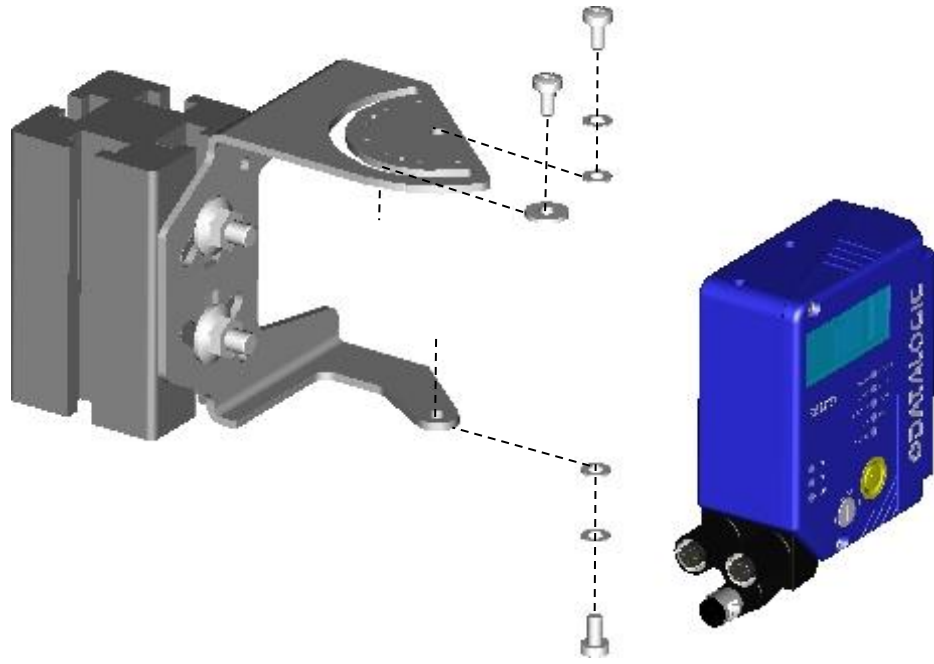

Figure 24 – Positioning with U Shape Mounting Bracket

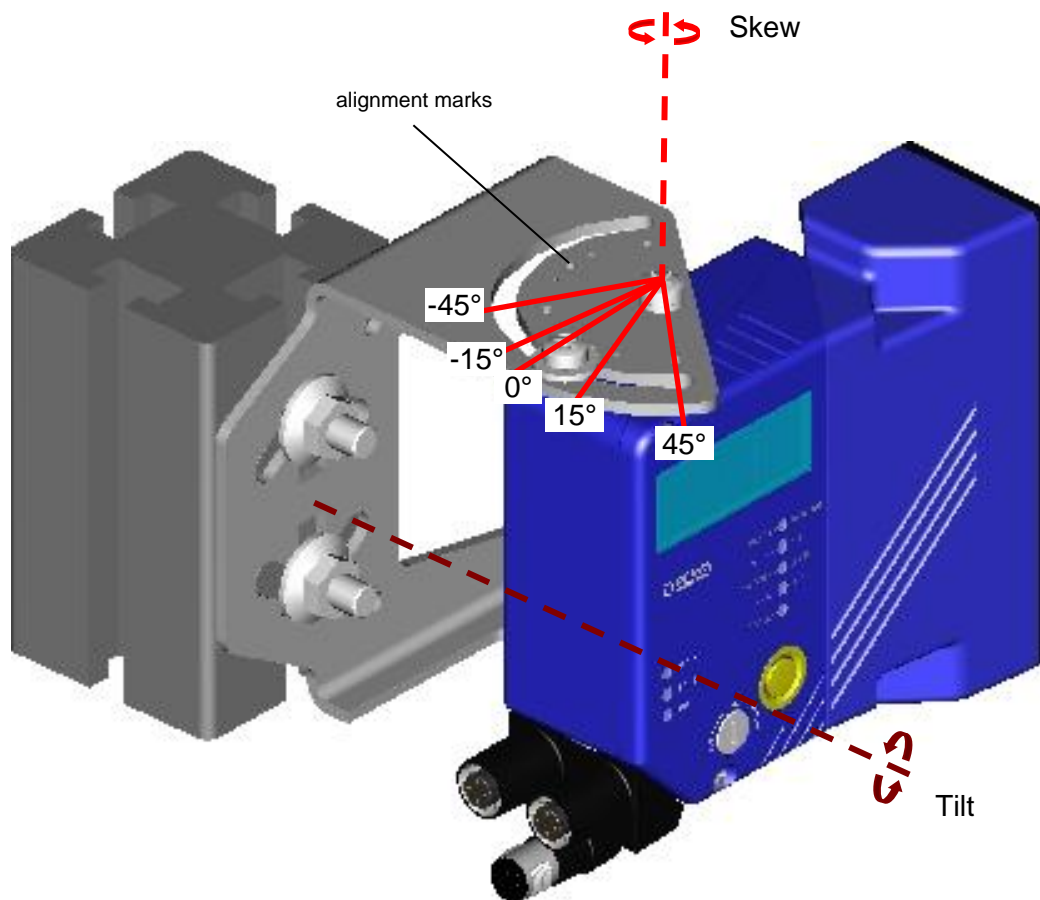
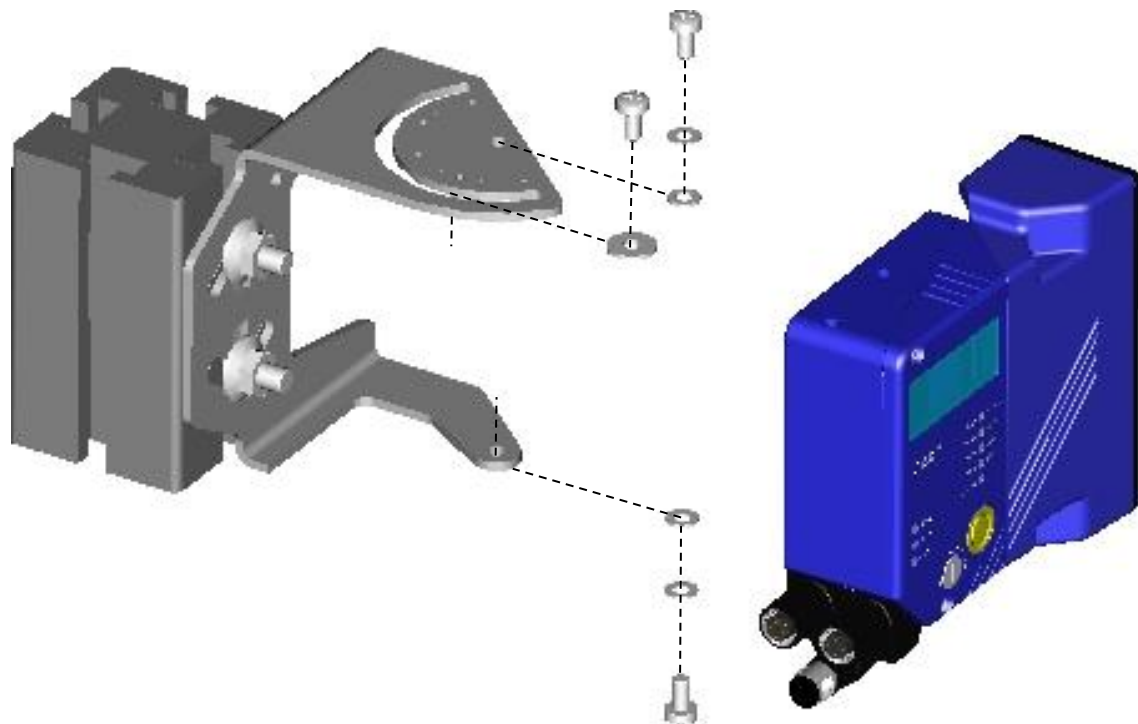

Figure 25 – DS5100 OM Positioning with U Shape Mounting Bracket

3.3 MOUNTING SCANNER ACCESSORIES

3.3.1 Mounting a GFC-40 Accessory Deflection Mirror

The GFC-40 is a 105° deflection reading mirror accessory that mounts directly to the DS5100 Scanner. It allows code reading in reduced space applications. The installation of the deflection mirror is very easy.

1. Make sure the device is not powered.
2. Remove the original 0° scanning window from the scanner by unscrewing the two captive cover screws.



Figure 26 - Removing the 0° Scanning Window



CAUTION: Avoid any contact with the deflection mirror, mirrored rotor, the lenses or other optical components; otherwise the performance of the reader will be reduced. Clean the deflection mirror surface and reading window with a clean soft cloth and alcohol before closing the scanner.

3. Check that the seal is correctly positioned (not symmetrical - curved seal corners towards scanner lower edge) and then after having aligned the GFC-40 onto the scanner, fix it with the two captive screws.

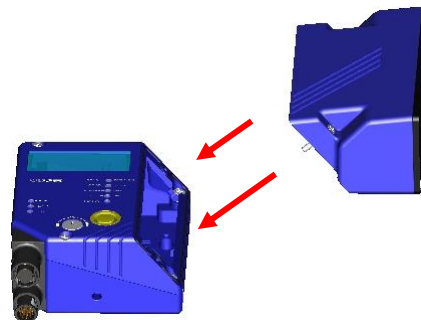

Figure 27 - Mounting the GFC-40 Deflection Mirror

The reading position with respect to the scanner is shown below.

105° ($\pm 2^\circ$) Embedded Skew Angle.

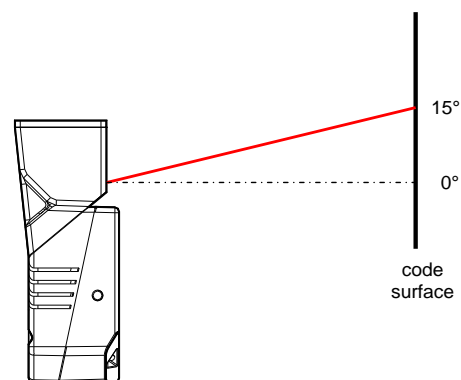

Figure 28 - GFC-40 Laser Beam Output Position

3.4 POSITIONING

The DS5100 scanner is able to decode moving barcode labels at a variety of angles, however significant angular distortion may degrade reading performance.

When mounting the DS5100 take into consideration these three ideal label position angles: **Skew 15° to 30°, Tilt 0° and Pitch 0°.**

Follow the suggestions for the best orientation:

The **Skew** angle is represented by the value **S** in Figure 29. Position the reader to **assure at least 15°** for the **Skew** angle. This avoids the direct reflection of the laser light emitted by the DS5100.

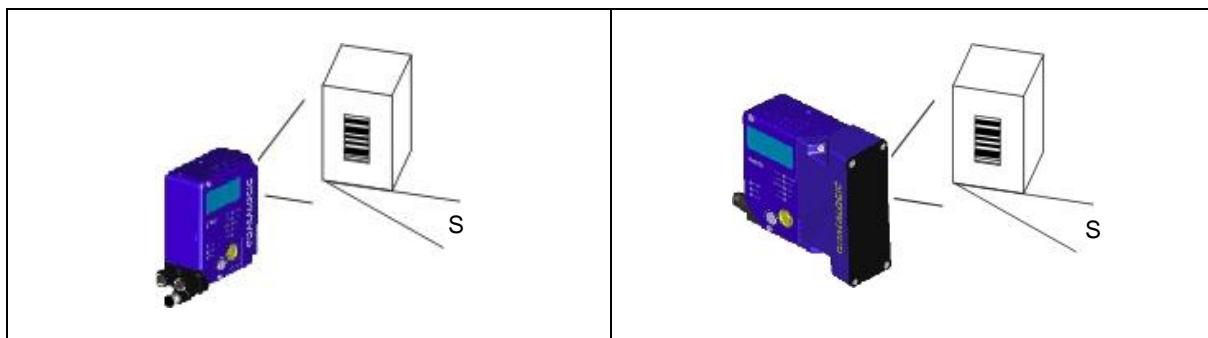

Figure 29 – DS5100 Skew Angle

The **Tilt** angle is represented by the value **T** in Figure 30. Position the reader in order to **minimize** the **Tilt** angle.

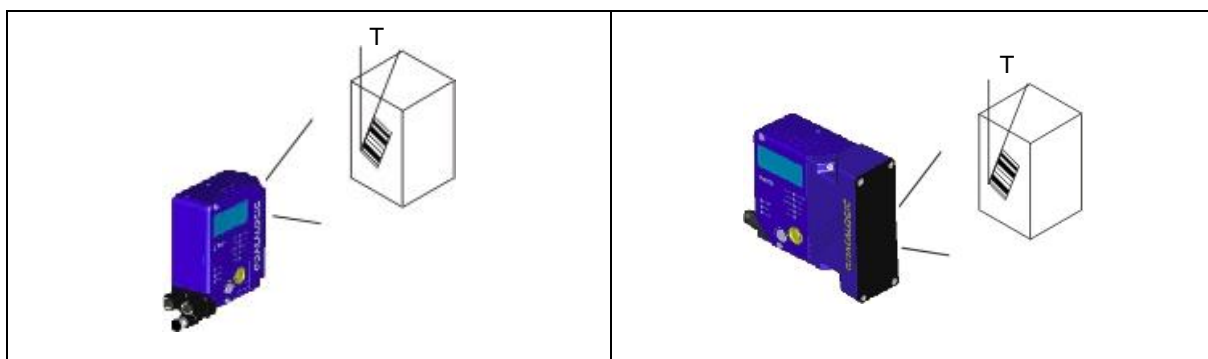

Figure 30 – DS5100 Tilt Angle

By using the ACR4 (Advanced Code Reconstruction) software parameter, the tilt angle is less critical and can be decoded even if the scan line doesn't cross the entire code.

See par. 6.1 or the Help On Line for details.

The **Pitch** angle is represented by the value **P** in Figure 31. Position the reader in order to **minimize** the **Pitch** angle.

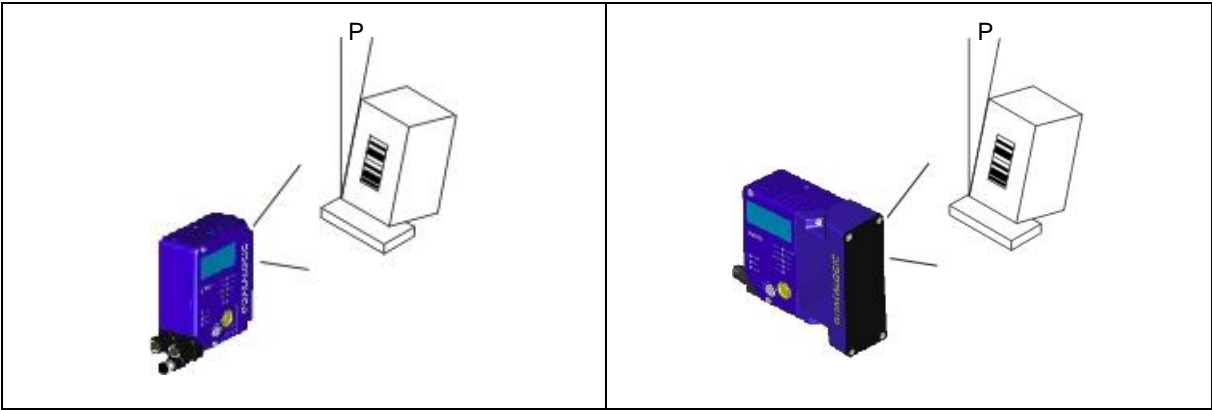

Figure 31 – DS5100 Pitch Angle

4 ELECTRICAL INSTALLATION

Serial Interface models are equipped with a cable terminated by a 25-pin male D-sub connector for connection to the power supply and input/output signals. For Ethernet models, an accessory 17-pin to 25-pin cable is available for CBX connections.

We recommend making system connections through one of the CBX connection boxes since they offer the advantages of easy connection, easy device replacement and filtered reference signals.



NOTE: If you require direct wiring to the scanner, the details of the connector pins and relative connections are indicated in Appendix A for Serial models or in Appendix B for Built-in Ethernet models.



NOTE: Profinet-IO models do not connect to the CBX connection boxes. The details of the connector pins and relative connections are indicated in Appendix C.

The table below gives the pinout of the CBX100/500 terminal block connectors. Use this pinout when the DS5100 reader is connected by means of the CBX100/500:

CBX100/500 Terminal Block Connectors	
Input Power	
Vdc	Power Supply Input Voltage +
GND	Power Supply Input Voltage -
Earth	Protection Earth Ground
Inputs	
+V	Power Source – External Trigger
I1A	External Trigger A (polarity insensitive)
I1B	External Trigger B (polarity insensitive)
-V	Power Reference – External Trigger
+V	Power Source – Inputs
I2A	Input 2 A (polarity insensitive)
I2B	Input 2 B (polarity insensitive)
-V	Power Reference – Inputs
Outputs	
+V	Power Source - Outputs
-V	Power Reference - Outputs
O1+	Output 1 +
O1-	Output 1 -
O2+	Output 2 +
O2-	Output 2 -
Auxiliary Interface	
TX	Auxiliary Interface TX
RX	Auxiliary Interface RX
SGND	Auxiliary Interface Reference
ID-NET	
REF	Network Reference
ID+	ID-NET network +
ID-	ID-NET network -
Shield	Network Cable Shield

Main Interface		
	RS232	RS485 Full-Duplex
	TX	TX+
	RX	*RX+
	RTS	TX-
	CTS	*RX-
	SGND	SGND

* Do not leave floating, see par. 4.2.2 for connection details.



NOTE: To avoid electromagnetic interference when the scanner is connected to a CBX connection box, verify the jumper positions in the CBX as indicated in its Installation Manual.

4.1 POWER SUPPLY

Power can be supplied to the scanner through the CBX100/500 spring clamp terminal pins as shown in Figure 32:

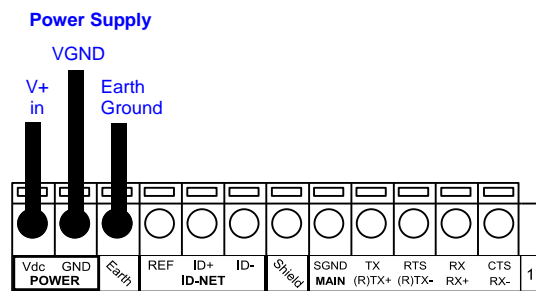

Figure 32 - Power Supply Connections

The power must be between 10 and 30 Vdc only.

It is recommended to connect the device CHASSIS to earth ground (Earth) by setting the appropriate jumper in the CBX connection box. See the CBX Installation Manual for details.

4.2 MAIN SERIAL INTERFACE



CAUTION: Do not connect to the Main Interface spring clamp terminals if using Host Interface Modules (Fieldbus) with the CBX500.

The signals relative to the following serial interface types are available on the CBX spring clamp terminal blocks.

If the interface type is not compatible with the current communication handshaking, then the system forces the handshake to **none**.

The main interface type and the relative parameters (baud rate, data bits, etc.) can be set using the Genius utility program or the Genius based Host Mode Programming procedure.

Details regarding the connections and use of the interfaces are given in the next paragraphs.

4.2.1 RS232 Interface

The serial interface is used in this case for point-to-point connections; it handles communication with the host computer and allows both transmission of code data and the programming of the scanner. This is the default setting.

The following pins are used for RS232 interface connection:

CBX100/500	Function
TX	Transmit Data
RX	Receive Data
RTS	Request To Send
CTS	Clear To Send
SGND	Signal Ground

It is always advisable to use shielded cables. The overall maximum cable length must be less than 15 m (49.2 ft).

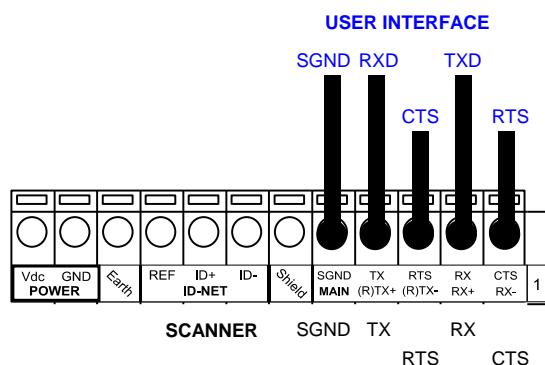

Figure 33 – RS232 Main Interface Connections Using Hardware Handshaking

The RTS and CTS signals control data transmission and synchronize the connected devices.

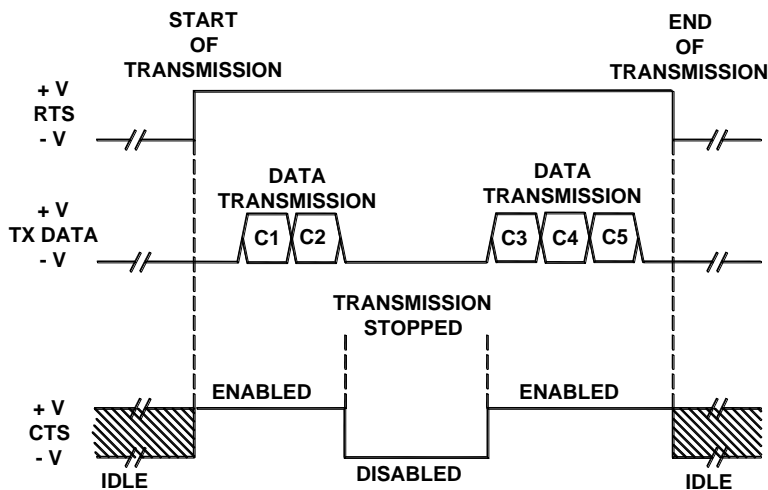

Figure 34 - RS232 Control Signals

If the RTS/CTS handshaking protocol is enabled, the DS5100 activates the RTS output to indicate a message is to be transmitted. The receiving unit activates the CTS input to enable the transmission.

4.2.2 RS485 Full-Duplex Interface

The RS485 full-duplex (5 wires + shield) interface is used for non-pollled communication protocols in point-to-point connections over longer distances (max 1200 m / 3940 ft) than those acceptable for RS232 communications or in electrically noisy environments.

The CBX pinout follows:

CBX100/500	Function
TX+	RS485 Transmit Data +
RX+	RS485 Receive Data +
TX-	RS485 Transmit Data -
RX-	RS485 Receive Data -
SGND	Signal Ground

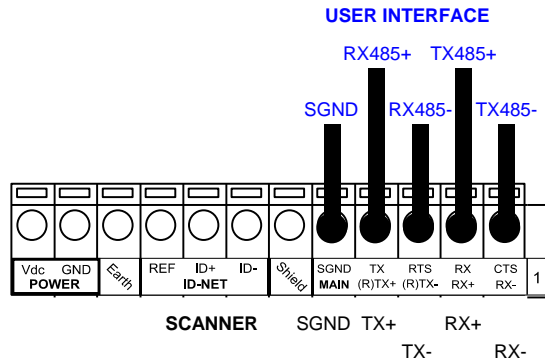

Figure 35 - RS485 Full-duplex Connections



NOTE: For applications that do not use RX485 signals, do not leave these lines floating but connect them to SGND as shown below.

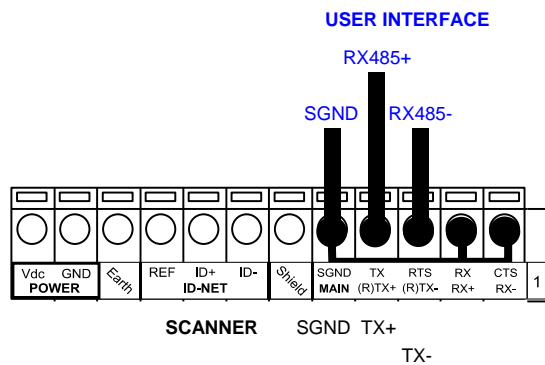

Figure 36 - RS485 Full-duplex Connections using Only TX Signals

4.3 ID-NET INTERFACE

CBX100/500	Function
Shield	Network Cable Shield
ID+	ID-NET network +
ID-	ID-NET network -
REF	Network Reference

4.3.1 ID-NET Cables

The following instructions are referred to Figure 38, Figure 39 and Figure 40.

- The general cable type specifications are: CAT5 twisted pair + additional CAT5 twisted pair, shielded cable AWG 24 (or AWG 22) stranded flexible.

We recommend using DeviceNet cables (drop or trunk type) to the following reference standards:

AN50325 – IEC 62026

UL STYLE 2502 80°C 30V

- Cable Shield MUST be connected to earth ground ONLY at the Master.
- NEVER use ID-NET cable shield as common reference.
- The ID-NET max cable length depends on the baudrate used, (see the Baudrate Table below).
- For Common Power Connections use only 2 wires (ID+ and ID-).
 - DC Voltage Power cable (Vdc – GND) should be handled as a signal cable (i.e. do not put it together with AC cable):
 - Wire dimensioning must be checked in order to avoid voltage drops greater than 0.8 Volts.
 - Cable should lie down as near as possible to the ID-NET cable (avoiding wide loops between them).
- Scanner's chassis may be connected to earth.
- Network inside the same building.

Baudrate Table				
Baud Rate	125 kbps	250 kbps	500 kbps	1Mbps
Cable Length	1200 m	900 m	700 m	*

* Application dependent, contact your Datalogic Automation representative for details.



NOTE: The default ID-NET baudrate is 500 kbps. Lower ID-NET baudrates allow longer cable lengths. The baudrate is software configurable by authorized Datalogic Automation personnel only.

4.3.2 ID-NET Response Time

The following figure shows the response time of the ID-NET network. This time is defined as the period between the Trigger activation and the beginning of data transmission to the Host.

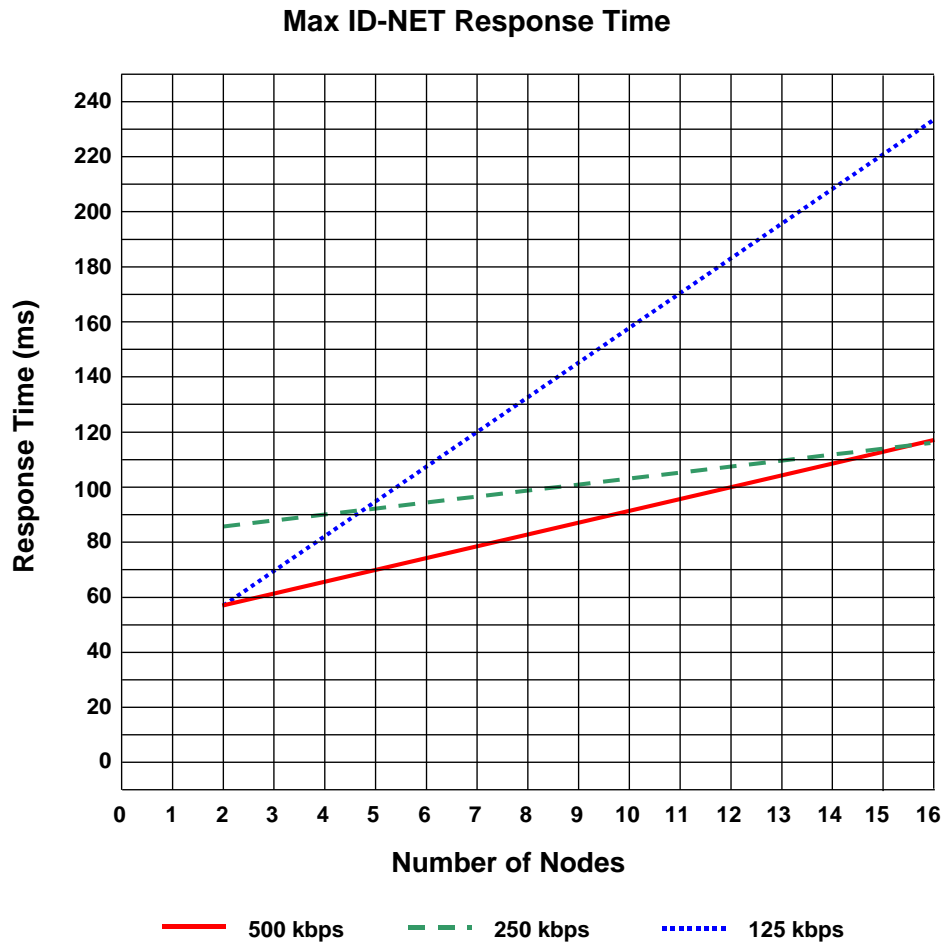

Figure 37 – ID-NET Response Time

CONDITIONS:

- ID-NET Synchronized layout
- message length = 50 bytes per node

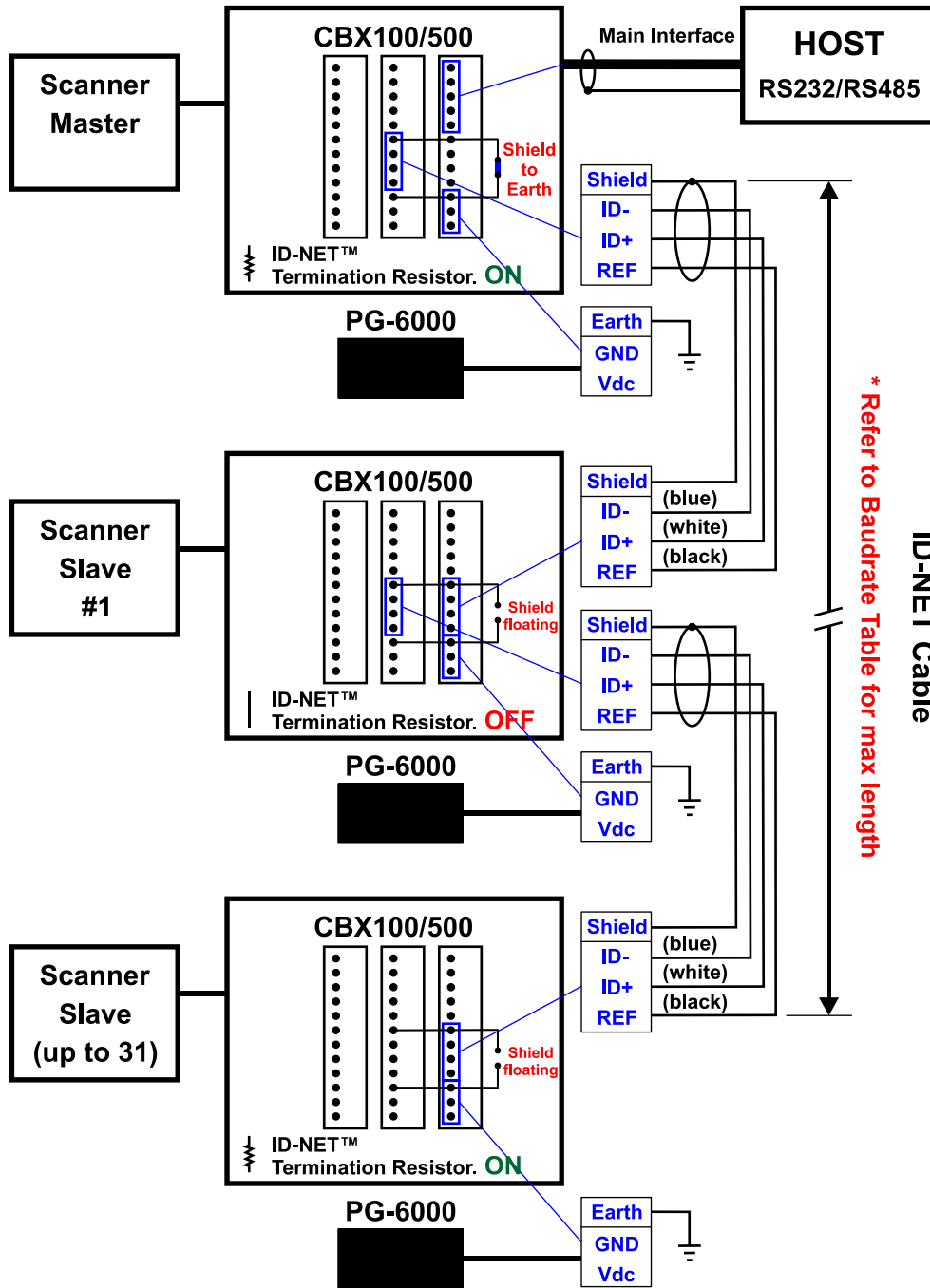

Figure 38 – ID-NET Network Connections with isolated power blocks

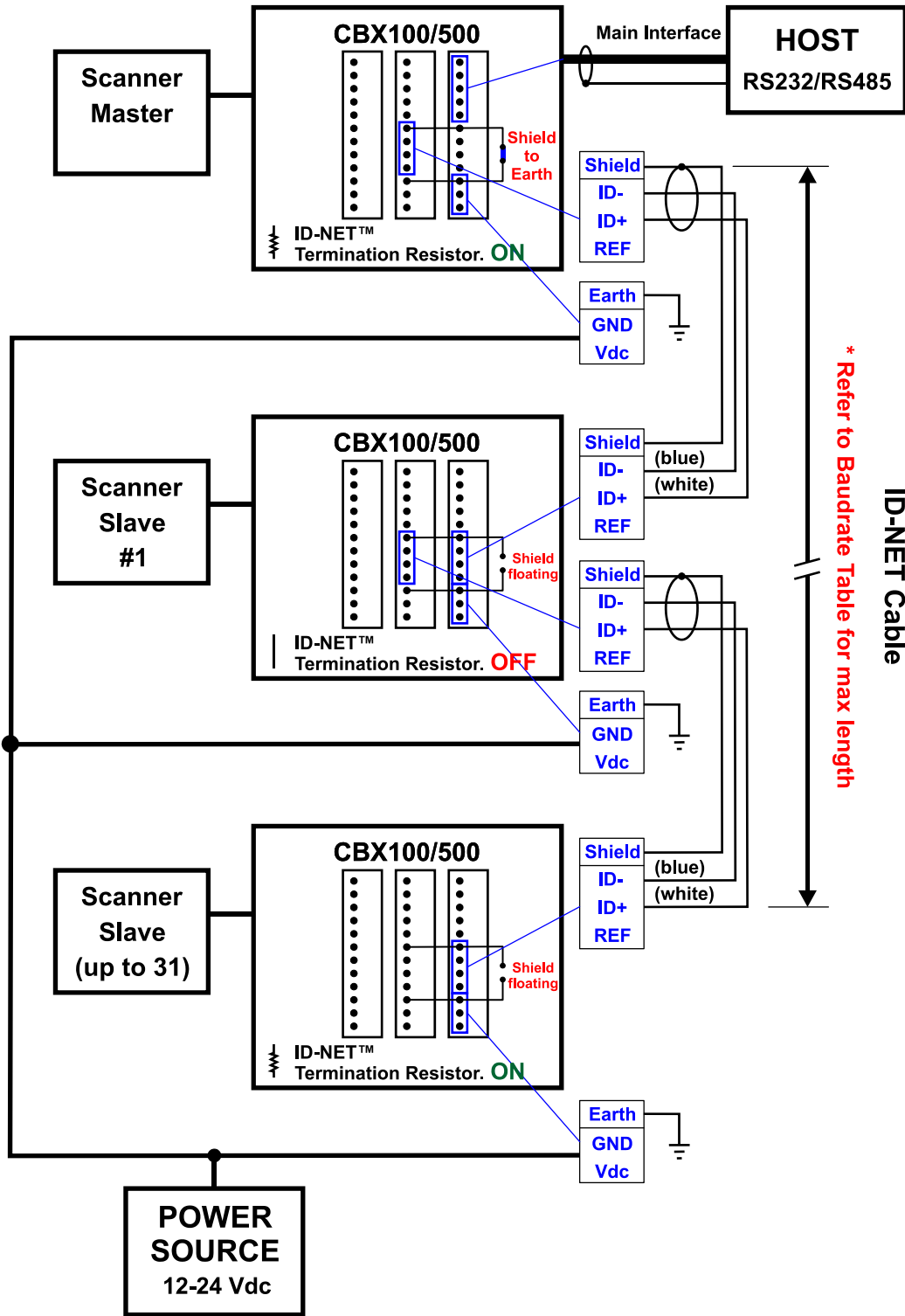

Figure 39 - ID-NET Network Connections with Common Power Branch Network

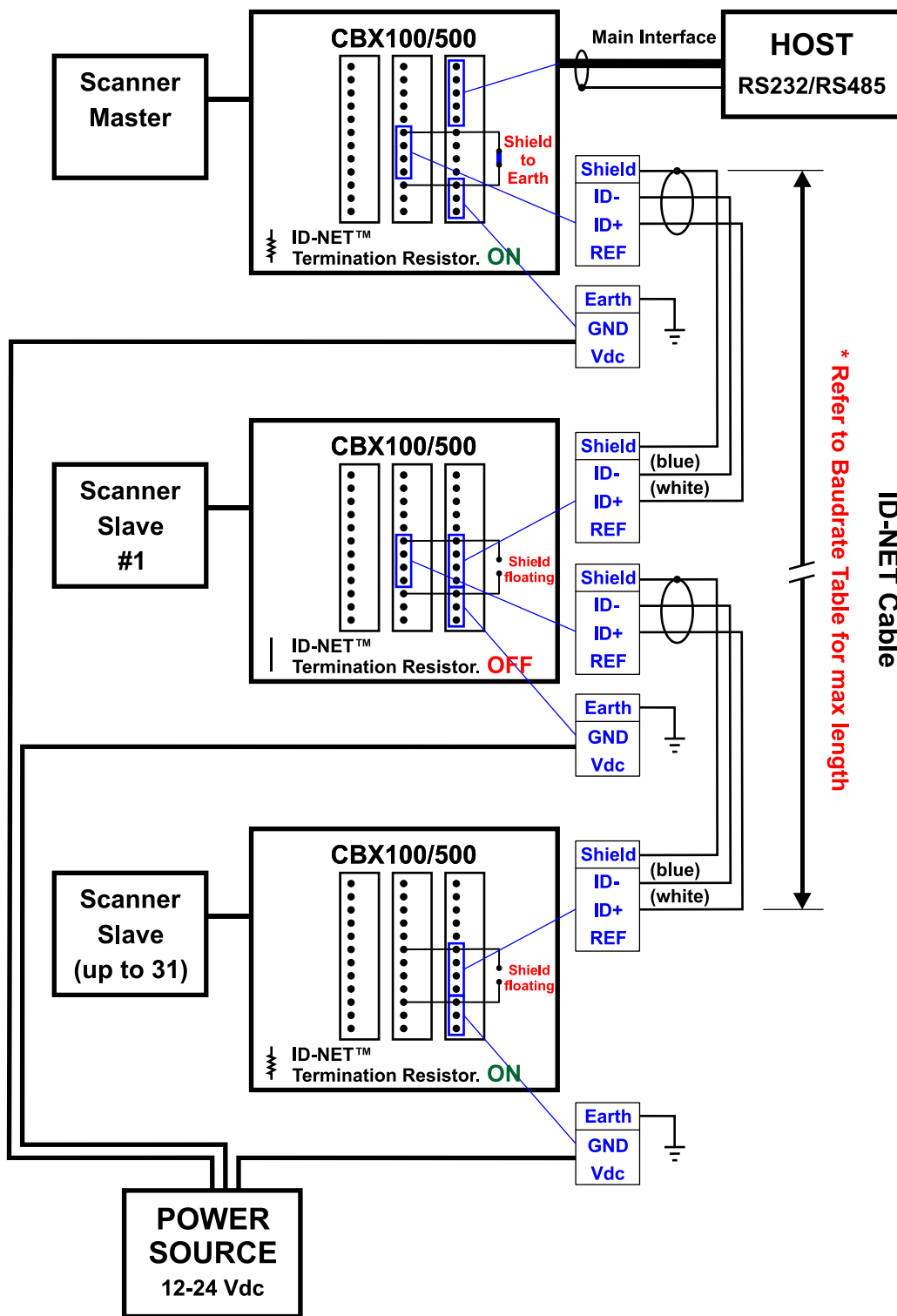

Figure 40 – ID-NET Network Connections with Common Power Star Network

4.3.3 ID-NET Network Termination

The network must be properly terminated in the first and last scanner of the network. This is done by setting the ID-NET Termination Resistance Switch in the CBX100/500 to ON.

4.4 AUXILIARY RS232 INTERFACE

The auxiliary serial interface is used exclusively for RS232 point-to-point connections.

The parameters relative to the aux interface (baud rate, data bits, etc.) as well as particular communication modes such as LOCAL ECHO can be defined using the Genius utility program or Genius-based Host Mode Programming provided on the downloadable Genius mini-DVD zip file.

The 9-pin female Auxiliary Interface connector inside the CBX is the preferred connector for device configuration or communication monitoring.

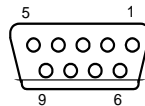

Figure 41 - 9-pin female connector

If permanent system wiring is required, the following pins are used to connect the RS232 auxiliary interface:

CBX100/500	Function
RX	Auxiliary Interface Receive Data
TX	Auxiliary Interface Transmit Data
SGND	Auxiliary Interface Reference

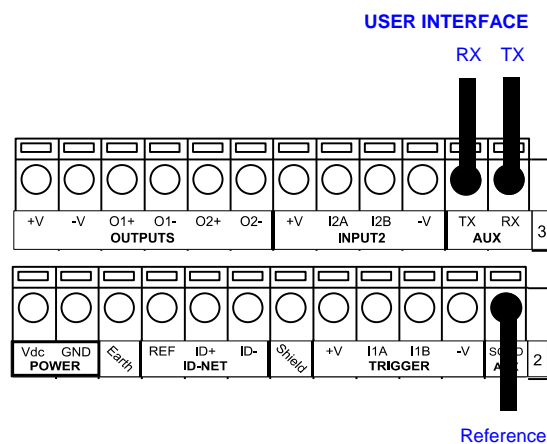

Figure 42 - RS232 Auxiliary Interface Connections



NOTE: Do not connect the Aux Interface to the CBX spring clamp connectors and the 9-pin connector simultaneously.

4.5 INPUTS

There are two optocoupled polarity insensitive inputs available on the scanner: Input 1 (External Trigger) and Input 2, a generic input:

The electrical features of both inputs are:

Maximum voltage:	30 Vdc
Maximum current:	12 mA (scanner) + 12 mA (CBX)

An anti-disturbance filter is implemented in software on both inputs so that the minimum pulse duration is \cong 5 milliseconds. This value can be increased through the software parameter Debounce Filter, see the "5K Family Software Configuration Parameter Guide" Help file".

CBX100/500	Function
+V	Power Source - External Trigger
I1A	External Trigger A (polarity insensitive)
I1B	External Trigger B (polarity insensitive)
-V	Power Reference - External Trigger

The External Trigger input is used in the On-Line operating Mode and tells the scanner to scan for a code. The active state of this input is selected in software. Refer to the Genius Help On Line.

The yellow Trigger LED ([Figure A, B, C, D, E](#), 7) is on when the active state of the External Trigger corresponds to ON.

This input is optocoupled and can be driven by both an NPN and PNP type command. The connections are indicated in the following diagrams:

EXTERNAL TRIGGER INPUT CONNECTIONS USING SCANNER POWER

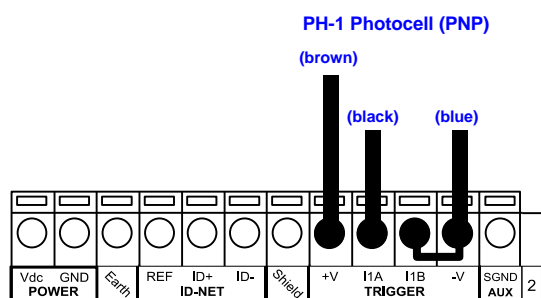
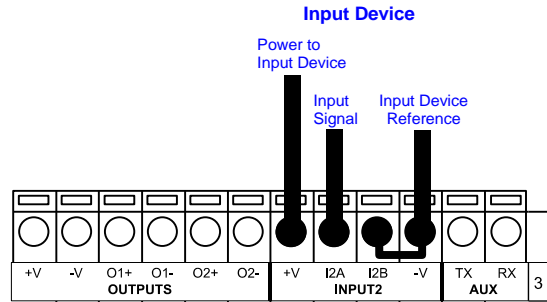

Figure 43 – PH-1 Photocell (PNP) External Trigger Using Scanner Power

CBX100/500	Function
+V	Power Source - Inputs
I2A	Input 2 A (polarity insensitive)
I2B	Input 2 B (polarity insensitive)
-V	Power Reference - Inputs

INPUT 2 CONNECTIONS USING SCANNER POWER



PNP Input 2 Using Scanner Power

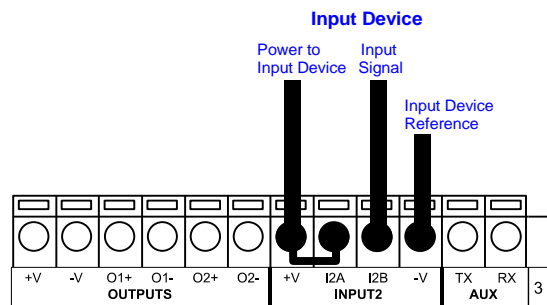

NPN Input 2 Using Scanner Power

INPUT 2 CONNECTIONS USING EXTERNAL POWER

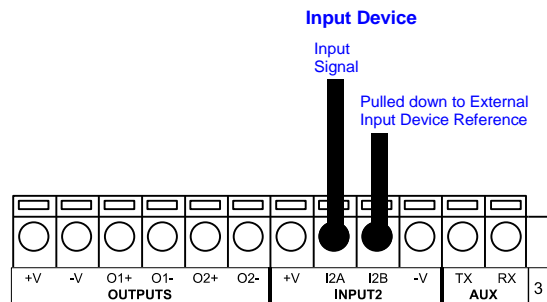

Figure 47 - PNP Input 2 Using External Power

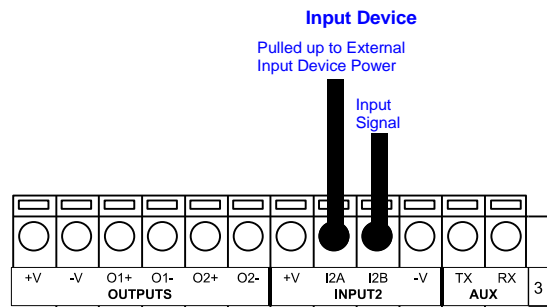

Figure 48 - NPN Input 2 Using External Power

4.5.1 Code Verifier

If the scanner is used as a Code Verifier, the verifier code can be configured in software through the Genius configuration program. However it is also possible to use one of the inputs to trigger when the scanner should store a code read as the verifier code.

The Code Verifier parameter must be enabled, and the configuration parameters to allow correct Code Type reading must be saved to the scanner in order to read the verifier code.

When the selected input is activated, the next read code will be stored as the verifier code in the scanner's non-volatile (Flash) memory.

For more details see the Verifier Parameters in the "5K Family Software Configuration Parameter Guide" Help file".

4.6 OUTPUTS

Two general purpose outputs are available.



CAUTION: For Ethernet models, when **Outputs 1 and 2** are connected through the CBX connection box, they become opto-isolated and polarity sensitive and acquire the electrical characteristics listed below. To function correctly, they require setting the Output Type configuration parameter to NPN for the respective output.

CBX100/500	Function
+V	Power Source - Outputs
O1+	Output 1 +
O1-	Output 1 -
O2+	Output 2 +
O2-	Output 2 -
-V	Power Reference Outputs

The meaning of the two outputs Output 1 and Output 2 can be defined by the user (No Read, Right, Wrong, etc.). Refer to the Genius Help On Line.

By default, Output 1 is associated with the No Read event, which activates when the code signaled by the external trigger is not decoded, and Output 2 is associated with the Complete Read event, which activates when all the selected codes are correctly decoded.

The output signals are fully programmable being determined by the configured Activation/Deactivation events, Deactivation Timeout or a combination of the two.

The electrical features of the outputs are the following:

$V_{CE} = 30 \text{ Vdc max.}$
$I_{CE} = 40 \text{ mA continuous max.; } 130 \text{ mA pulsed max.}$
$V_{CE \text{ saturation}} = 1 \text{ Vdc max. @ } 10 \text{ mA}$
$P_D = 90 \text{ mW Max. @ } 50 \text{ }^\circ\text{C ambient temp.}$

OUTPUT 1 AND 2 CONNECTIONS USING SCANNER POWER



CAUTION: Power from the Vdc/GND spring clamps is available directly to the Output Device on the +V/-V spring clamps, and does not pass through the Power Switch (ON/OFF) inside the CBX. Disconnect the power supply when working inside the CBX.

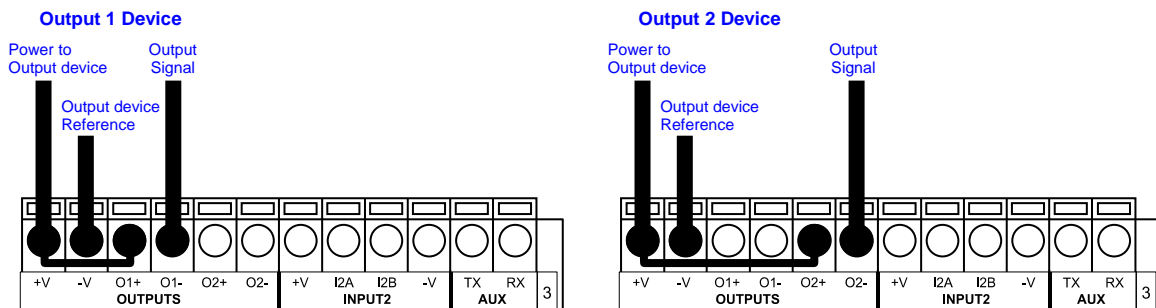

Figure 49 - PNP/Open Emitter Output Using Scanner Power

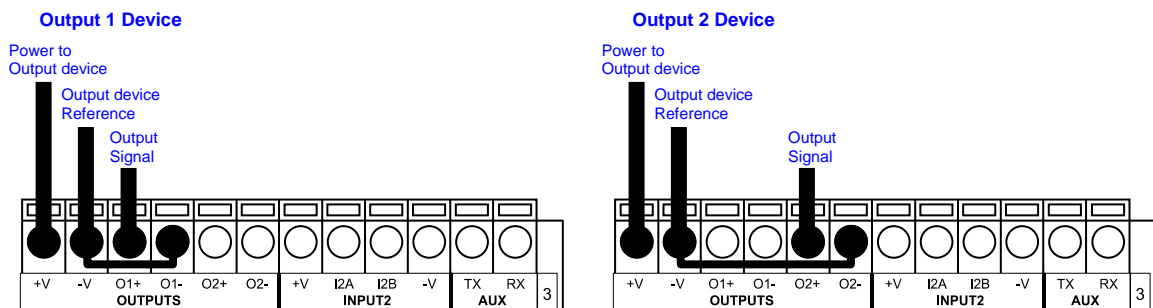

Figure 50 - NPN/Open Collector Output Using Scanner Power

OUTPUT 1 AND 2 CONNECTIONS USING EXTERNAL POWER

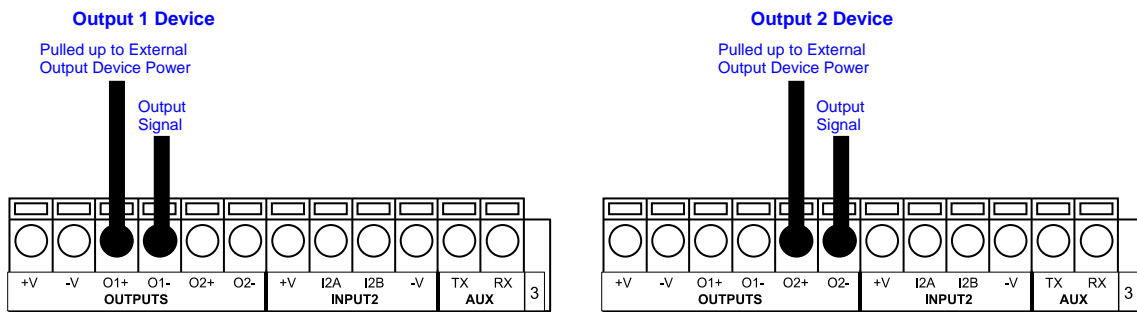

Figure 51 - PNP/Output Open Emitter Using External Power

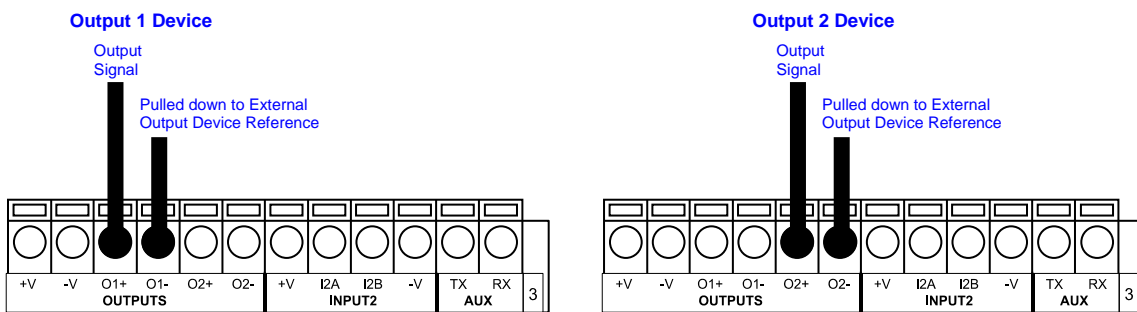

Figure 52 - NPN/Output Open Collector Using External Power

4.7 USER INTERFACE - HOST

The following table contains the pinout for standard RS232 PC Host interface. For other user interface types please refer to their own manual.

RS232 PC-side connections			
<p>9-pin male connector</p>		<p>25-pin male connector</p>	
Pin	Name	Pin	Name
2	RX	3	RX
3	TX	2	TX
5	GND	7	GND
7	RTS	4	RTS
8	CTS	5	CTS

5 TYPICAL LAYOUTS

The following typical layouts refer to system hardware configurations. Dotted lines in the figures refer to optional hardware configurations within the particular layout.

These layouts also require the correct setup of the software configuration parameters. Complete software configuration procedures can be found in the **Guide To Rapid Configuration** in the Genius Help On Line.

5.1 POINT-TO-POINT

In this layout the data is transmitted to the Host on the main serial interface. A Genius based Host Mode programming can be accomplished either through the main interface or the Auxiliary interface.

In Local Echo communication mode, data is transmitted on the RS232 auxiliary interface independently from the main interface selection.

When On-Line Operating mode is used, the scanner is activated by an External Trigger (photoelectric sensor) when the object enters its reading zone.

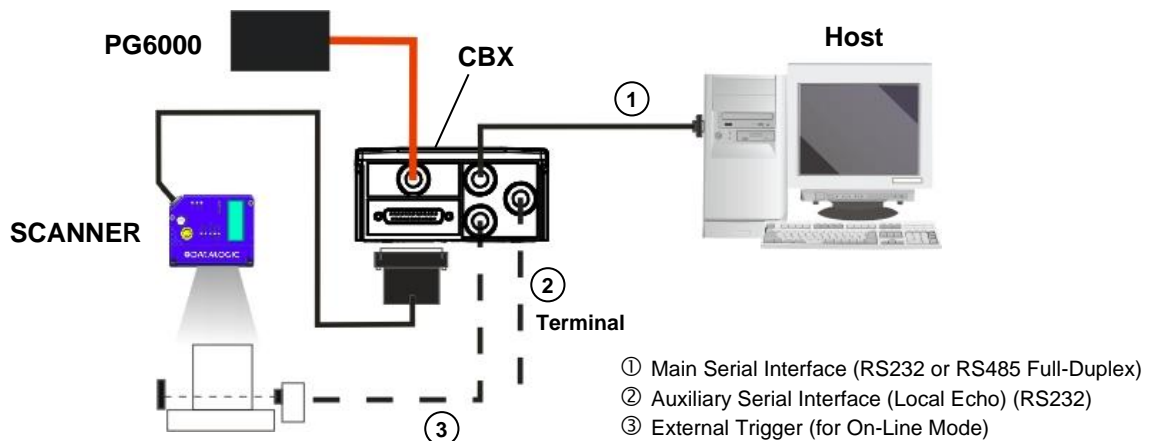

Figure 53 – Serial Interface Point-to-Point Layout

5.2 EXTERNAL FIELDBUS USING HOST MODE INTERFACE MODULES

In this layout a single scanner functions as a Slave node on a Fieldbus network. The data is transmitted to the Host through an accessory Fieldbus interface board installed inside the CBX500 connection box.

Scanner configuration can be accomplished through the Auxiliary interface using the Genius configuration program or Genius based Host Mode programming.

In Local Echo communication mode, data is transmitted on the RS232 auxiliary interface independently from the Fieldbus interface selection.

When On-Line Operating mode is used, the scanner is activated by an External Trigger (photoelectric sensor) when the object enters its reading zone.

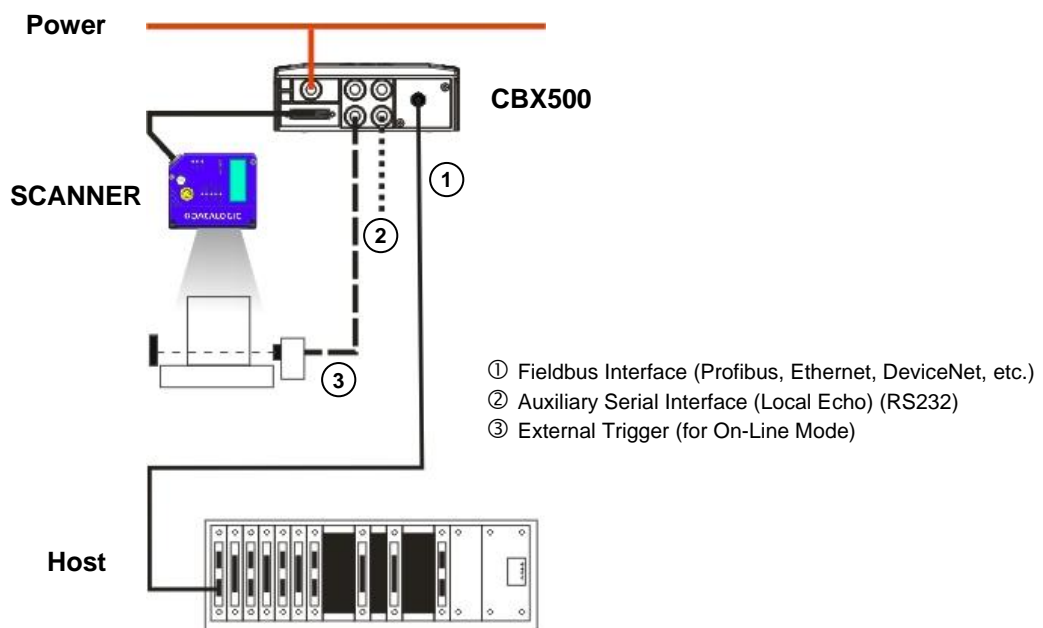

Figure 54 – External Fieldbus Interface Point-to-Point Layout

5.3 BUILT-IN ETHERNET NETWORKS

5.3.1 External Trigger Ethernet Host (x3xx models only)

In this layout, before proceeding with the connection, it is necessary to configure the reader Ethernet parameters via Genius. For further details see par. 2.10.

When using a Local Area Network (LAN), one or more DS5100-x3xx model scanners can be connected to the network by using **CAB-ETH-M0x** cables. In the example below Power and an External Trigger are brought to each scanner through a CBX connection box using the **CAB-DS0x-S** cables.

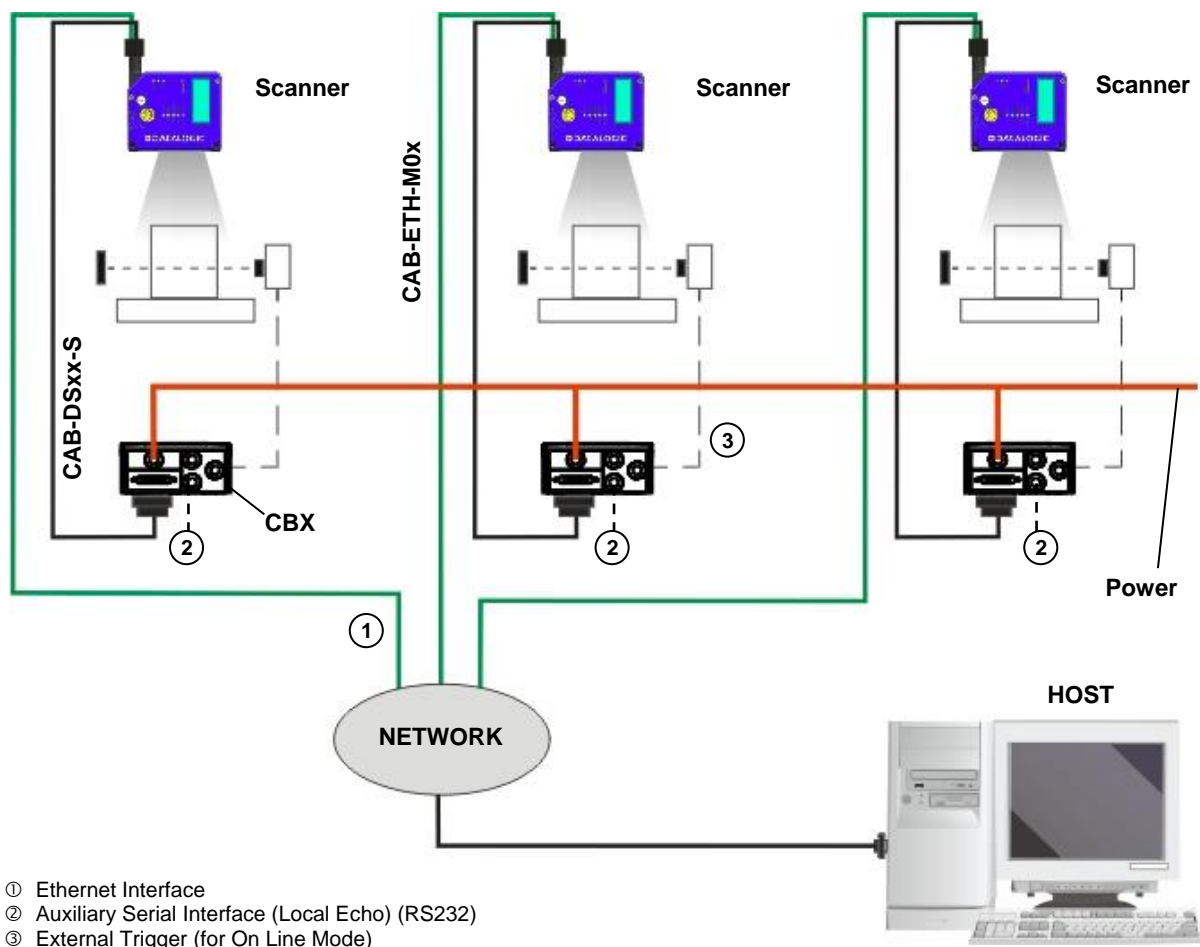

Figure 55 - Ethernet TCP/IP Network Layout

5.4 BUILT-IN PROFINET-IO NETWORKS

The PROFINET-IO interface is used to collect data from several readers to build a multi-point or a multi-sided reading system; there can be one PROFINET-IO Controller (Host) and up to 255 PROFINET-IO Devices (Scanners) connected together in the same subnetwork.

Before proceeding with the connection, it is necessary to configure the scanner. This can be done via Genius through the Ethernet socket. For further details see par. 2.10. Once a connection is established, the scanner can also be configured by sending Host Mode programming strings from the PLC, see the 5K Host Mode Programming Manuals.

5.4.1 Multi Station Layout with Single Port Scanners (x3xx models)

One or more DS5100-x3xx model scanners can be connected to the network by using **CAB-ETH-M0x** cables connected to a Certified PROFINET-IO Switch or PLC. Every scanner must have its own unique Station Name (see Profinet-IO Line Parameters in Help On Line).

For a Multi Station layout each scanner independently receives the Trigger signal (Trigger Input from presence sensor, Input from Fieldbus Host, or Serial Start/Stop from Fieldbus Host) and each scanner sends its message to the Host.

In the example below, Power and an External Trigger are brought to each scanner through a CBX connection box using the **CAB-DS0x-S** cables.

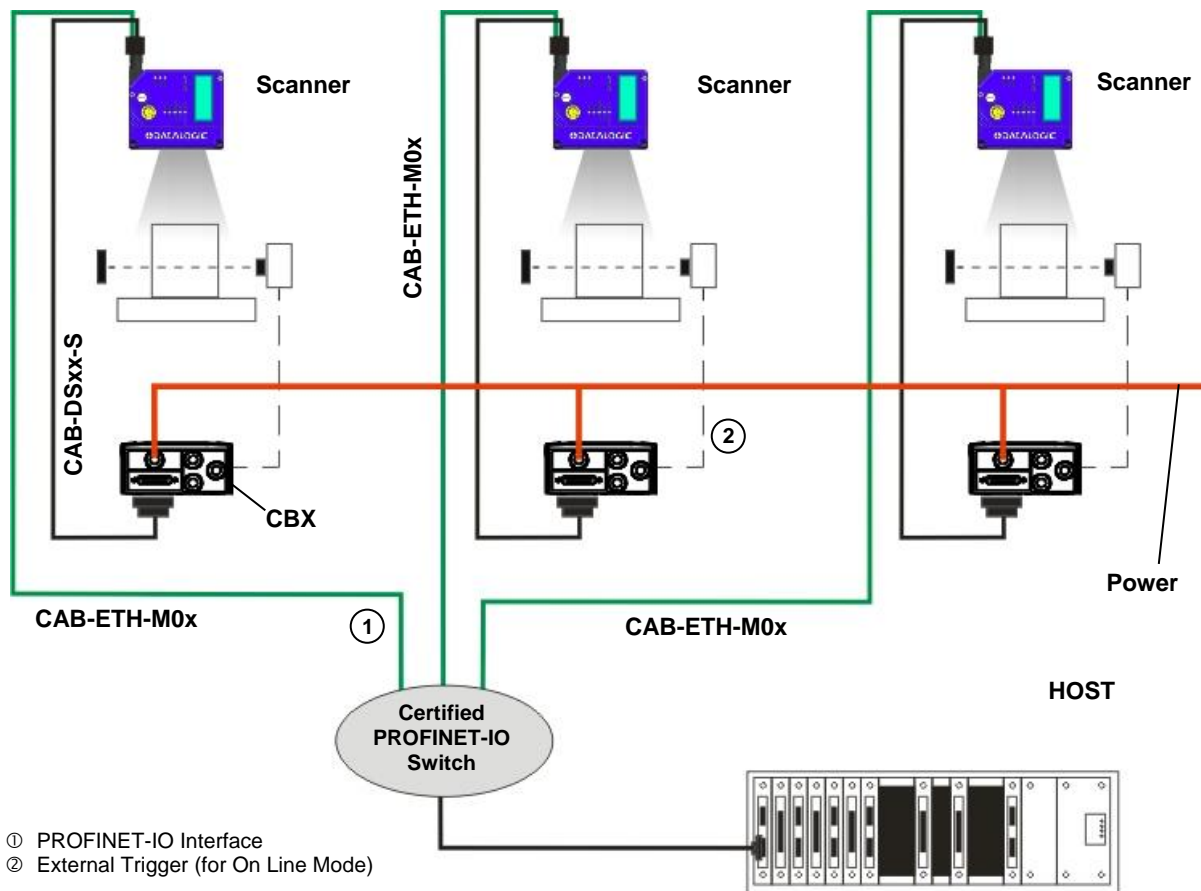

Figure 56 – PROFINET-IO Multi Station Layout (Single Port Models)

5.4.2 Single Station Layout with Dual Port Scanners (x4xx models)

More than one DS5100-x4xx (dual port) model scanner is chained together in the PROFINET-IO network by using an **ETH CABLE M12-M12** cable. The first scanner in the chain is connected to a Certified PROFINET-IO Switch or PLC using a **CAB-ETH-M0x** cable. The last scanner has a protection cap to cover the unused port. Every scanner must have its own unique Station Name (see Profinet-IO Line Parameters in Help On Line).

For a Single Station layout each scanner simultaneously receives the Trigger signal (Trigger Input from presence sensor, Input from Fieldbus Host, or Serial Start/Stop from Fieldbus Host) and each scanner sends its message to the Host.

Power connections can be made using the CS-A1-02 or AS-I accessory power cables to the power source. This cable also allows the External Trigger Input to be connected to a presence sensor (see Appendix C for details).

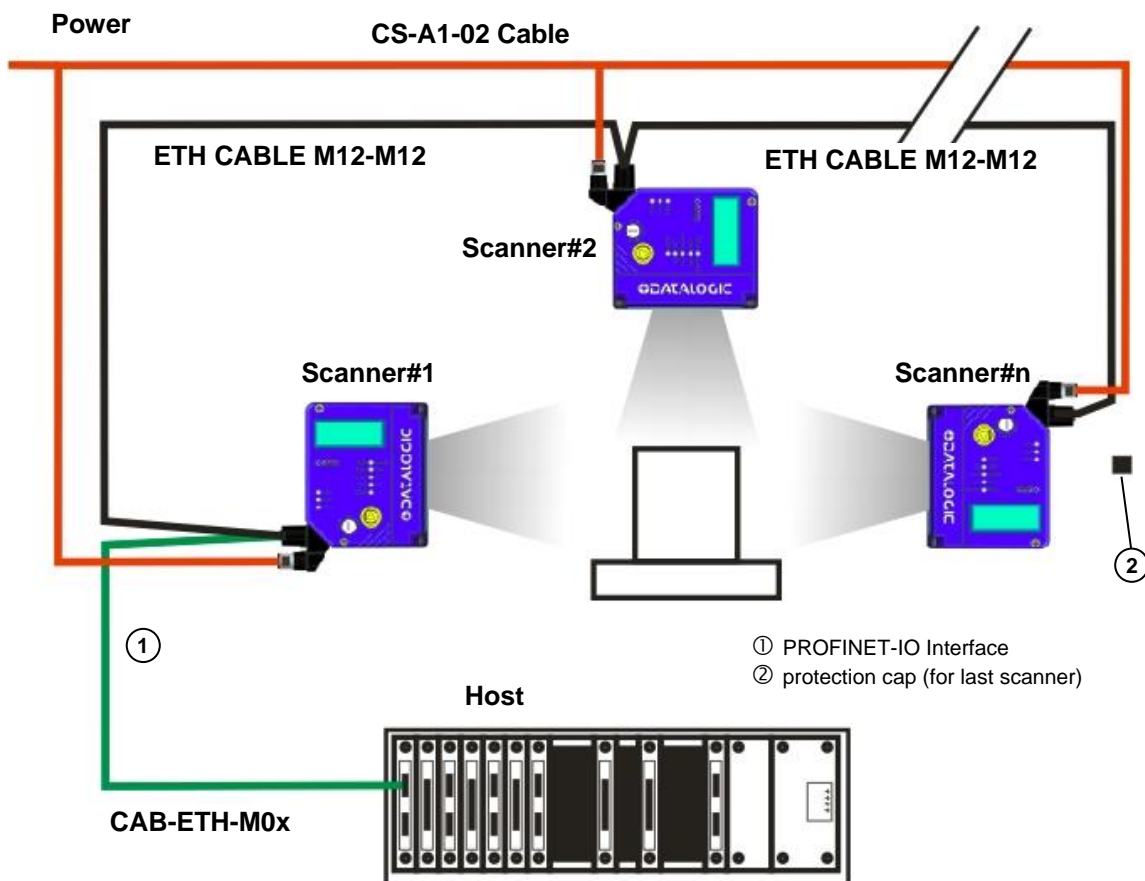

Figure 57 – PROFINET-IO Single Station Layout (Dual Port Models)

5.4.3 Multi Station Layout with Dual Port Scanners (x4xx models only)

More than one DS5100-x4xx (dual port) model scanner is chained together in the PROFINET-IO network by using an **ETH CABLE M12-M12** cable. The first scanner in the chain is connected to a Certified PROFINET-IO Switch or PLC using a **CAB-ETH-M0x** cable. The last scanner has a protection cap to cover the unused port. Every scanner must have its own unique Station Name (see Profinet-IO Line Parameters in Help On Line).

For a Multi Station layout each scanner independently receives the Trigger signal (Trigger Input from presence sensor, Input from Fieldbus Host, or Serial Start/Stop from Fieldbus Host) and each scanner sends its message to the Host.

Power connections can be made using the CS-A1-02 or AS-I accessory power cables to the power source. This cable also allows the External Trigger Input to be connected to a presence sensor (see Appendix C for details).

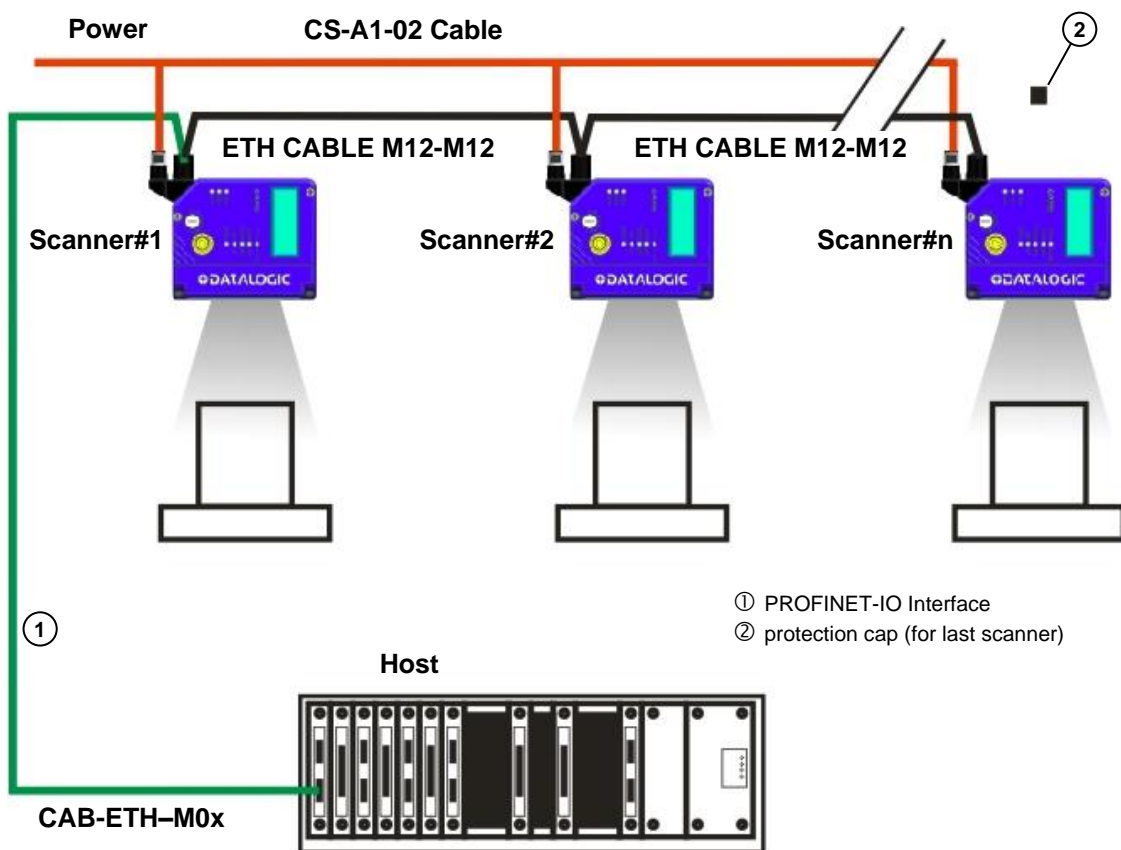

Figure 58 – PROFINET-IO Multi Station Layout (Dual Port Models)

5.5 EBC™ NETWORKS (x4xx models only)

The DS5100 dual port model can be integrated into a Large Synchronized Network (multi-scanner reading station) using the proprietary EBC network interface. The SC5000 (Controller) is the station master and the DS5100 and/or DS8110/DX8210 EBC slave scanners are connected together in the same subnetwork.

The slave scanners are chained together in a ring topology using the EBC interface with ETH CABLE M12-M12 cables.

Power connections can be made using the CS-A1-02 or AS-I accessory power cables to the power source.

The “Trigger” signal is sent through the SC5000 to all the readers simultaneously and each scanner sends its message to the SC5000 Master which relays a single message to the Host computer. See below for DS5100 configuration details and the SC5000 Reference Manual for more system details.

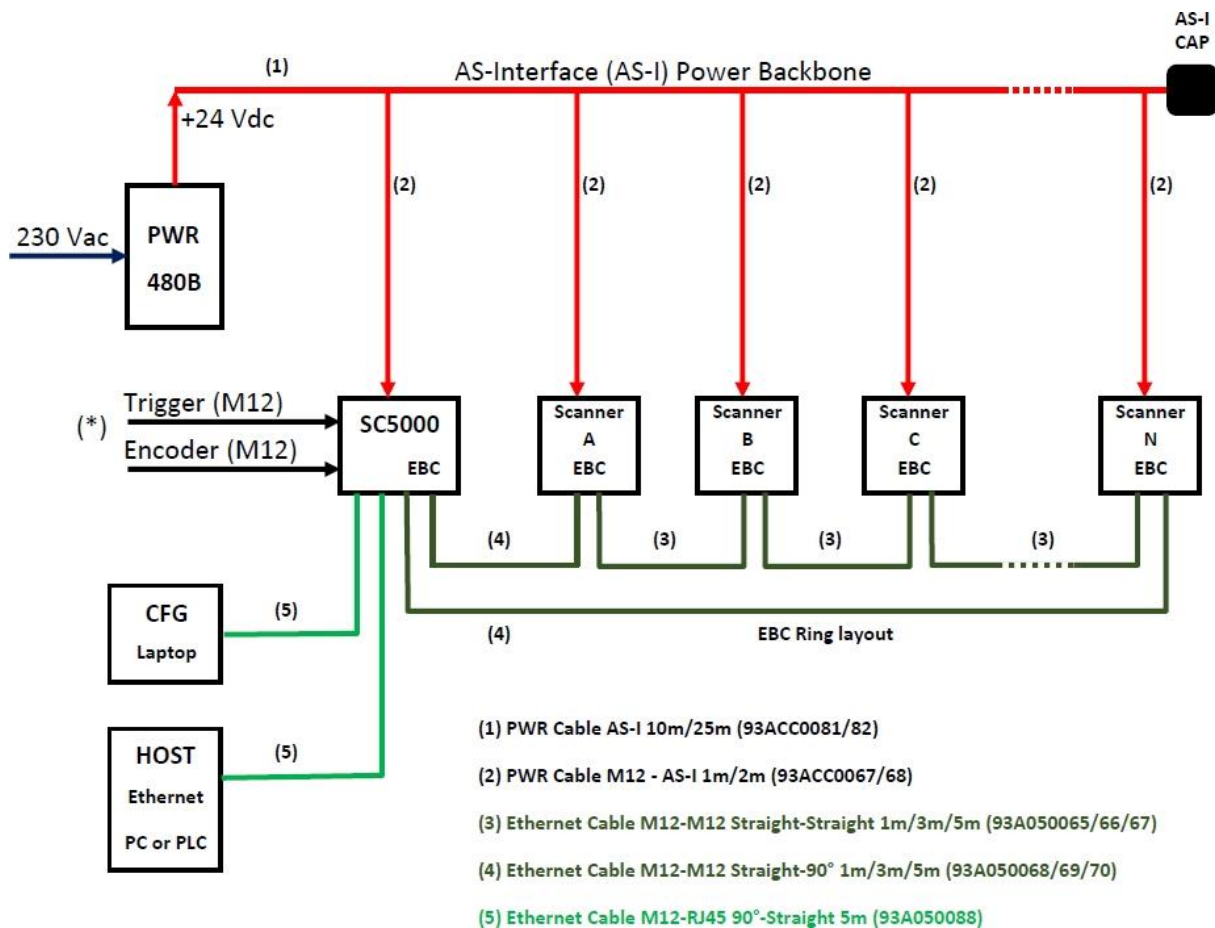

Figure 59 – Large Synchronized Network with DS5100 Scanners



NOTE: The DS5100 scanners must be configured through Genius™. They will be shown and monitored through the SC5000 e-Genius GUI but they cannot be configured by it. Follow the procedure below for configuration.

DS5100-x4xx models can only be integrated into EBC networks as slave scanners where SC5000 is the Master Controller. To do this:

1. Physically mount and electrically connect the DS5100 scanner in the application.
2. To set the DS5100 scanner as an EBC Slave, follow the [EBC network selection](#) procedure described in step 4, X-PRESS Configuration.
3. Run Discovery from the SC5000 System Info page to discover all scanners in the network.

The screenshot shows the SC5000 Datalogic GUI. The 'Discover Scanners' button is highlighted with a red box. The 'Device Information' section contains the following table:

Model	Dev	MAC Addr	Software Version	Description	
	0	0007BE0099C7	ARM_release_v3_1_2_0	Controller	
	1	000E1304010F	ARM_SS5281_v3_1_2_4	Right	ID
	2	000E1304010D	ARM_SS5281_v3_1_2_4	Top Right	ID
	3	0007BE00F239	ARM_SS5281_v3_1_2_4	Back	ID
	4	0007BE00DABE	ARM_SS5281_v3_1_2_4	Front	ID
	5	0007BE013E9E	ARM_SS5281_v3_1_2_4	Top Left	ID
	6	000E13040102	ARM_SS5281_v3_1_2_4	Left	ID
	7	0007BE013B1E	ARM_SS5281_v3_1_2_4	Bottom Left	ID
	8	0007BE00EF8D	ARM_SS5281_v3_1_2_4	Bottom Right	ID

Below the table is an 'Edit...' dropdown. The 'Unconfigured Devices' section shows a table with one entry:

	MAC Addr	Model
1	0007BE0380DA	DS5100-2400

Below this is another 'Edit...' dropdown. The 'Additional Devices' section has a checkbox for 'Send Barcodes to Non-Singulated Dimensioning System' which is currently unchecked. At the bottom of the GUI are buttons for 'Update All', 'Reset All', and 'Reset Page'. The footer shows '© 2017 Datalogic'.



NOTE: The DS5100 scanners can also be added to the EBC network using the Add button in the SC5000 GUI.

- Give a descriptive name to the DS5100 scanner (typically scanner position) and then press the Update All button.

SC5000 **DATALOGIC™**

System Info

System Description:

Role:

Enable Automatic Slave Replace:

Master Tools

Device Information

Model	Dev	MAC Addr	Software Version	Description	
	0	0007BE0099C7	ARM_release_v3_1_2_0	Controller	
	1	000E1304010F	ARM_SS5281_v3_1_2_4	Right	ID
	2	000E1304010D	ARM_SS5281_v3_1_2_4	Top Right	ID
	3	0007BE00F239	ARM_SS5281_v3_1_2_4	Back	ID
	4	0007BE00DABE	ARM_SS5281_v3_1_2_4	Front	ID
	5	0007BE013E9E	ARM_SS5281_v3_1_2_4	Top Left	ID
	6	000E13040102	ARM_SS5281_v3_1_2_4	Left	ID
	7	0007BE013B1E	ARM_SS5281_v3_1_2_4	Bottom Left	ID
	8	0007BE00EF8D	ARM_SS5281_v3_1_2_4	Bottom Right	ID
	9	0007BE0380DA	APL_5KPNIO_STD_1.0.0.368	New Scanner	ID

Edit...

Additional Devices

Send Barcodes to Non-Singulated Dimensioning System

© 2017 Datalogic

- From the SC5000 Utilities menu launch Genius.
- Run the Get command to open the DS5100 Controller.

SC5000 **DATALOGIC™**

Utilities | Launch Genius

Launch Genius Configurator for DS5100

- Backup or Restore
- Reboot
- Update Firmware
- **Launch Genius**
- Help

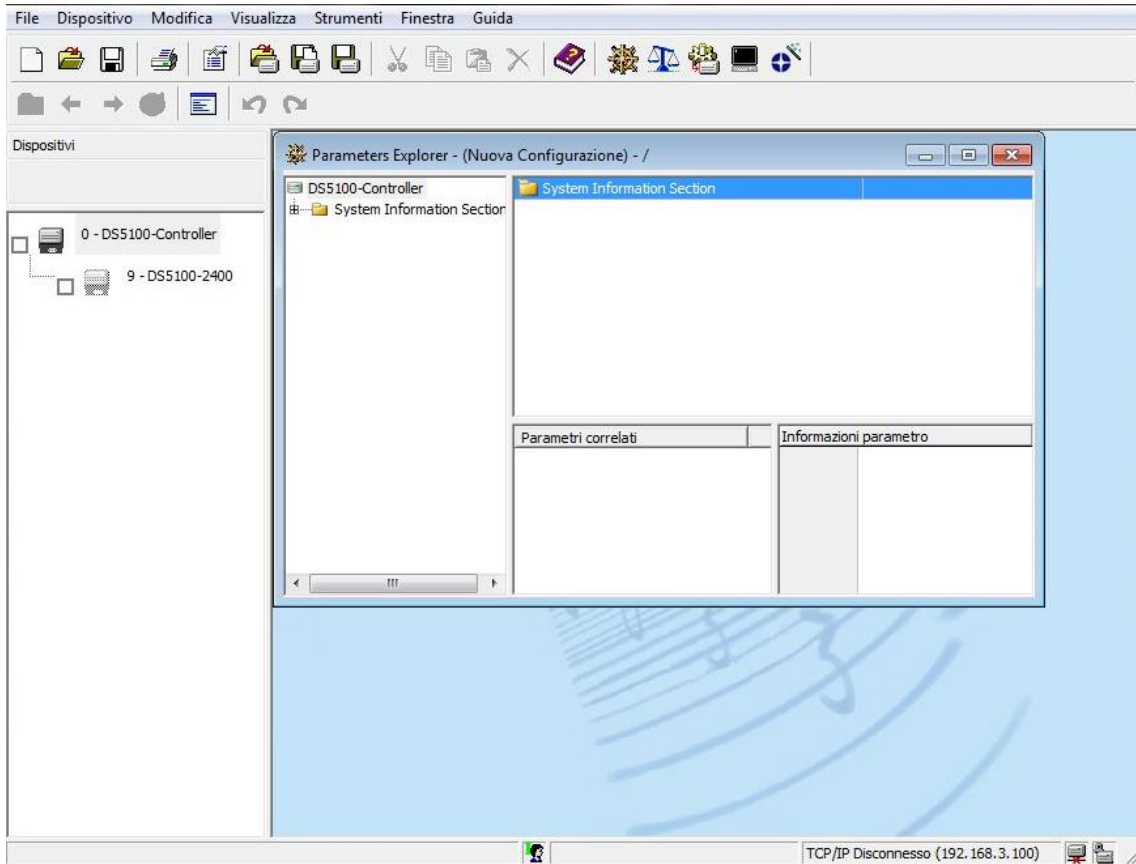

7. Double-click on the DS5100 scanner to configure it.

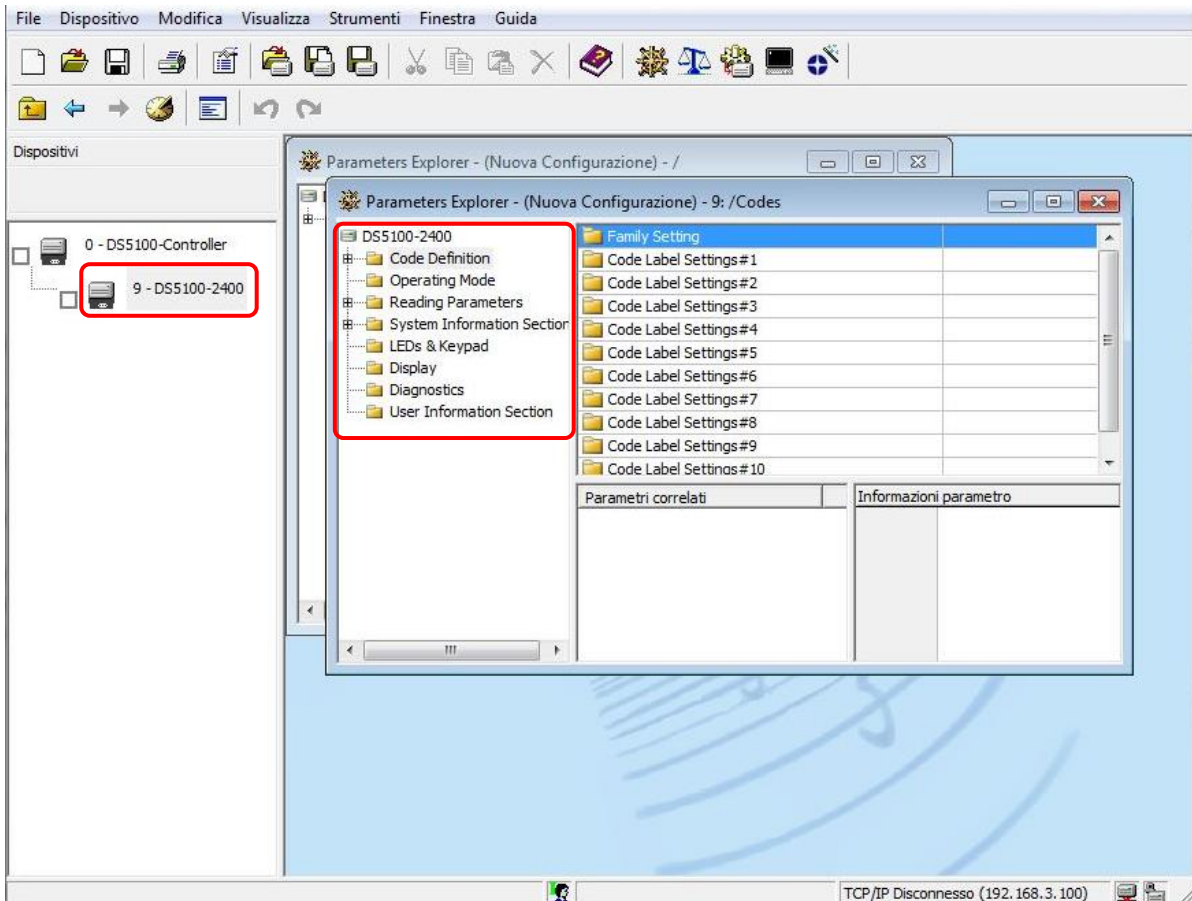

Common parameters to configure/check are:

- Code Settings
- Operating Mode: PackTrack (default) or On Line, etc.
- Focus Lock



NOTE: The PackTrack operating mode is only available for dual port long range models working in EBC (DS5100-24xx).

8. Save the configuration to the DS5100 scanner in Genius.
9. Save the entire EBC network (slave scanners + SC5000 configuration) backup on the Compact Flash in the SC5000. See the SC5000 Reference Manual for details.

The DS5100 can also be used in Redundant System applications (REDs).

5.6 ID-NET SYNCHRONIZED NETWORKS

The ID-NET connection is used to collect data from several scanners to build a multi-point or a multi-sided reading system; there can be one master and up to 31 slaves connected together.

The slave scanners are connected together using the ID-NET interface. Every slave scanner must have a ID-NET address in the range 1-31.

The master scanner is also connected to the Host on the RS232/RS485 main serial interface.

For a Master/Slave Synchronized layout the External Trigger signal is unique to the system; there is a single reading phase and a single message from the master scanner to the Host computer. **It is not necessary to bring the External Trigger signal to all the scanners.**

The main, auxiliary, and ID-NET interfaces are connected as shown in the figure below.

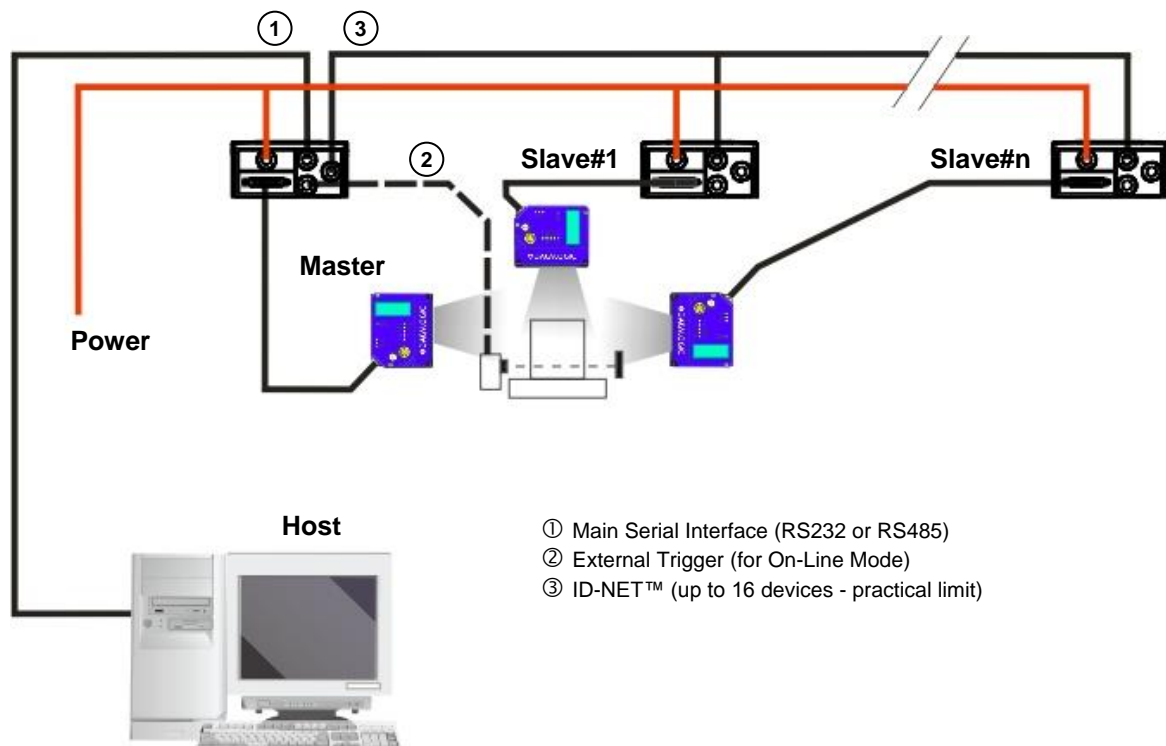

Figure 60 – ID-NET Synchronized Layout

The Master scanner can be connected to the CBX series connection box (CBX + BM100 module) or to a QL500 having sw version 2.02.01 and later, with the advantage of the Backup and Restore configuration function.



NOTE: The auxiliary serial interface of the slave scanners can be used in Local Echo communication mode to control any single scanner (visualize collected data) or to configure it using the Genius utility or the Genius based Host Mode programming procedure.

The ID-NET termination resistor switches must be set to ON only in the first and last CBX connection box.

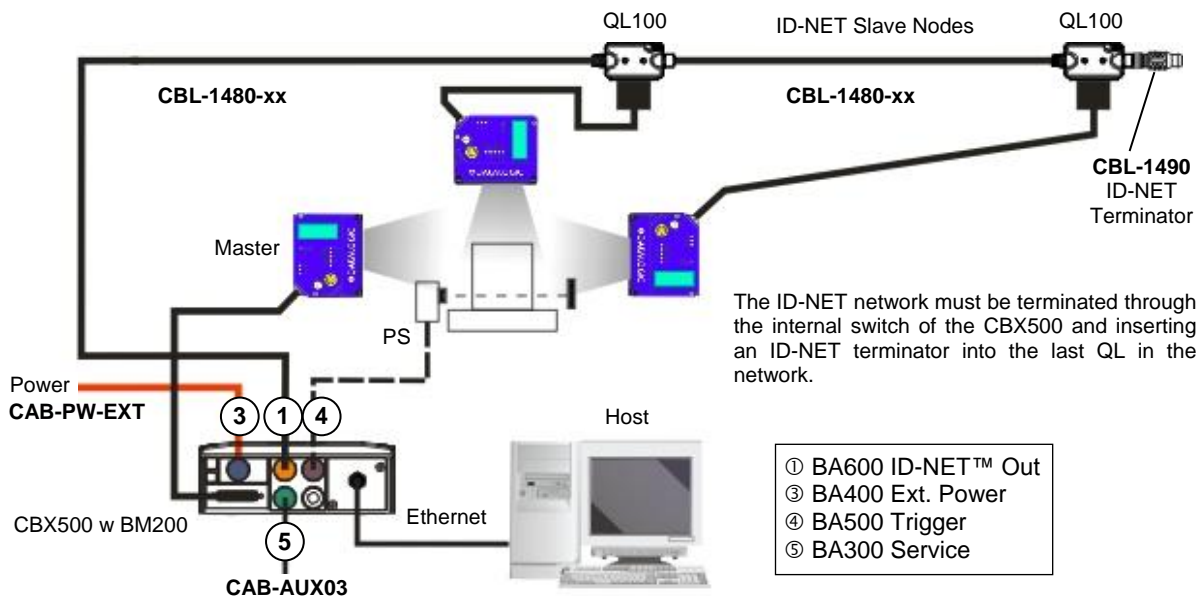

**Figure 61 – ID-NET Synchronized Layout
DS5100 Master with CBX500 + DS5100 Slaves with QL100**

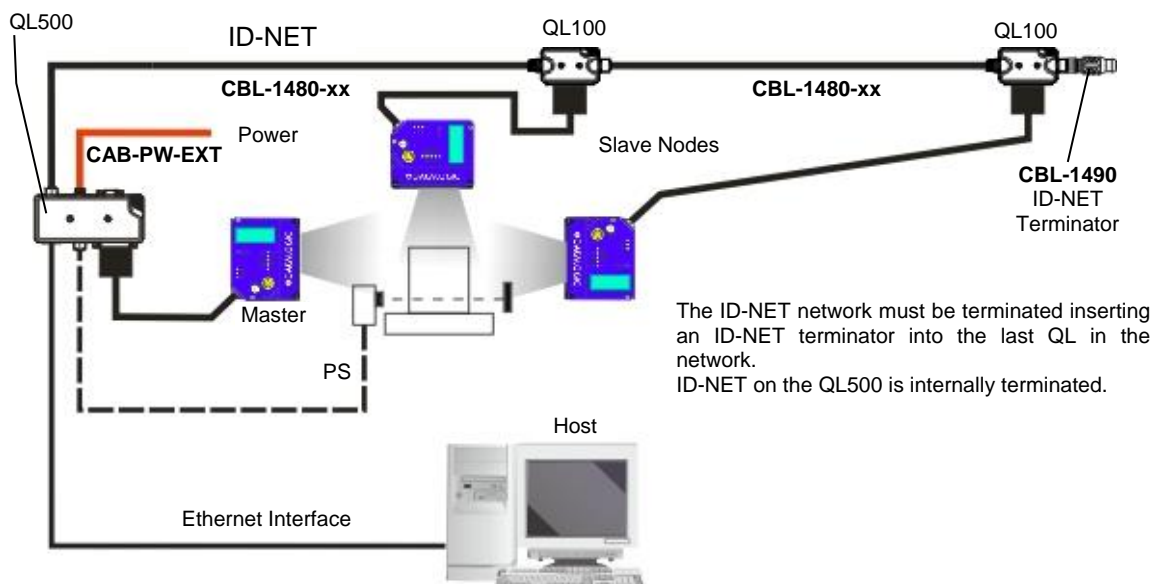
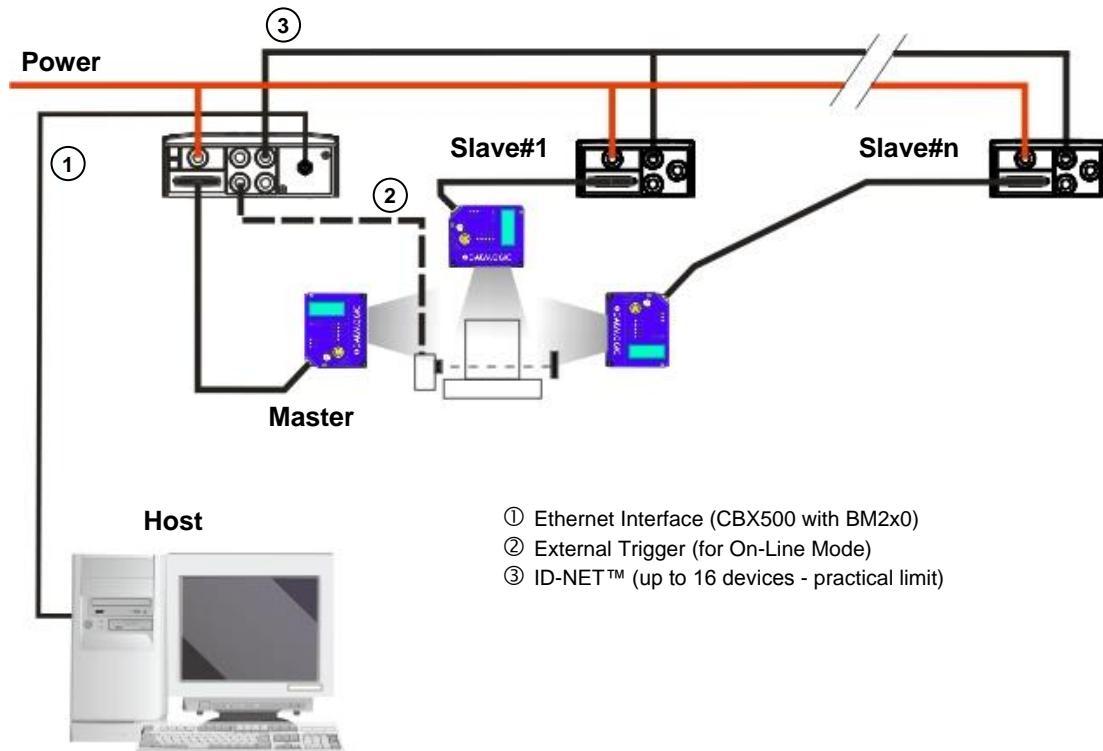

**Figure 62 – ID-NET Synchronized Layout
DS5100 Master with QL500 + DS5100 Slaves with QL100**

The Master scanner can communicate to the Host as a Slave node on an Ethernet TCP/IP network. This example requires using the accessory BM2x0 Ethernet interface board installed inside the CBX500 connection box.

System configuration can be accomplished through the Auxiliary interface of the Master scanner (internal CBX500 9-pin connector) using the Genius configuration program or Genius based Host Mode programming.

Configuration can also be accomplished in Genius directly through the Ethernet network. In this case initial connection can be made using Programming Barcodes.



**Figure 63 – ID-NET Synchronized Layout
DS5100 Master with BM200/210 TCP/IP Ethernet Interface to Host**

Alternatively, the Master scanner can communicate to the Host as a Slave node on a Fieldbus network. This requires using an accessory Fieldbus interface board installed inside the CBX500 connection box.

System configuration can be accomplished through the Auxiliary interface of the Master scanner (internal CBX500 9-pin connector) using the Genius configuration program or Genius based Host Mode programming.

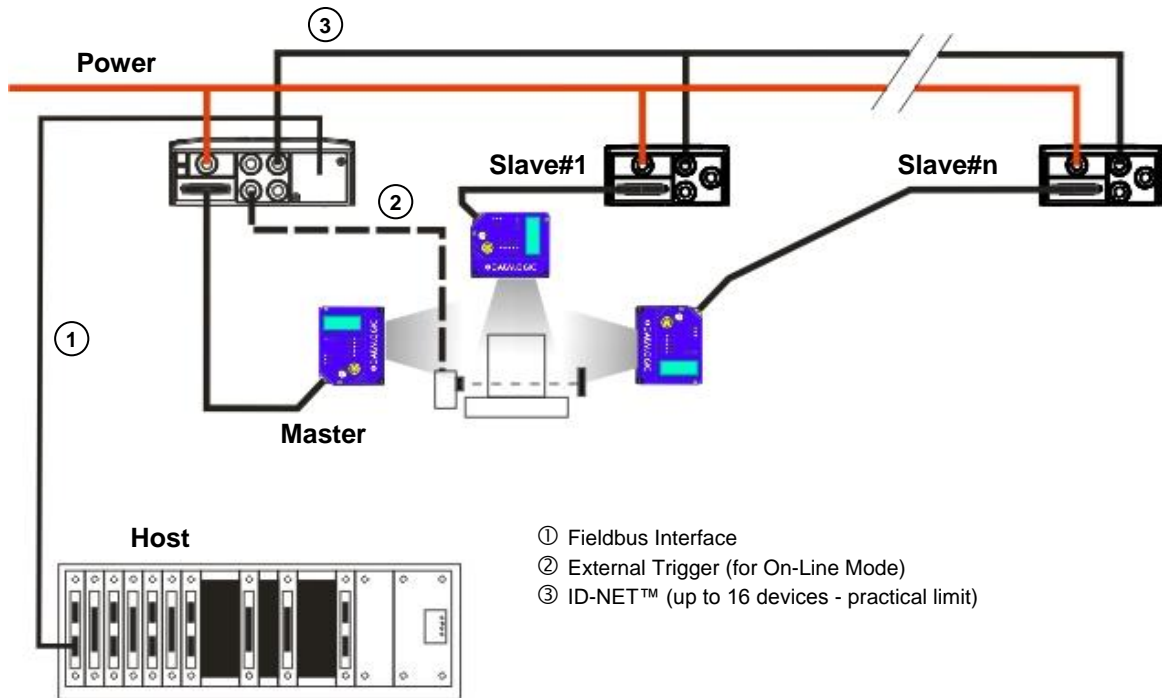

Figure 64 – ID-NET Fieldbus Synchronized Layout

The QLM600 Profibus Gateway active connection module can also be used. System configuration can be accomplished through the Auxiliary interface of the Master scanner (QLM600 Aux connector) using the Genius configuration program or Genius based Host Mode programming.

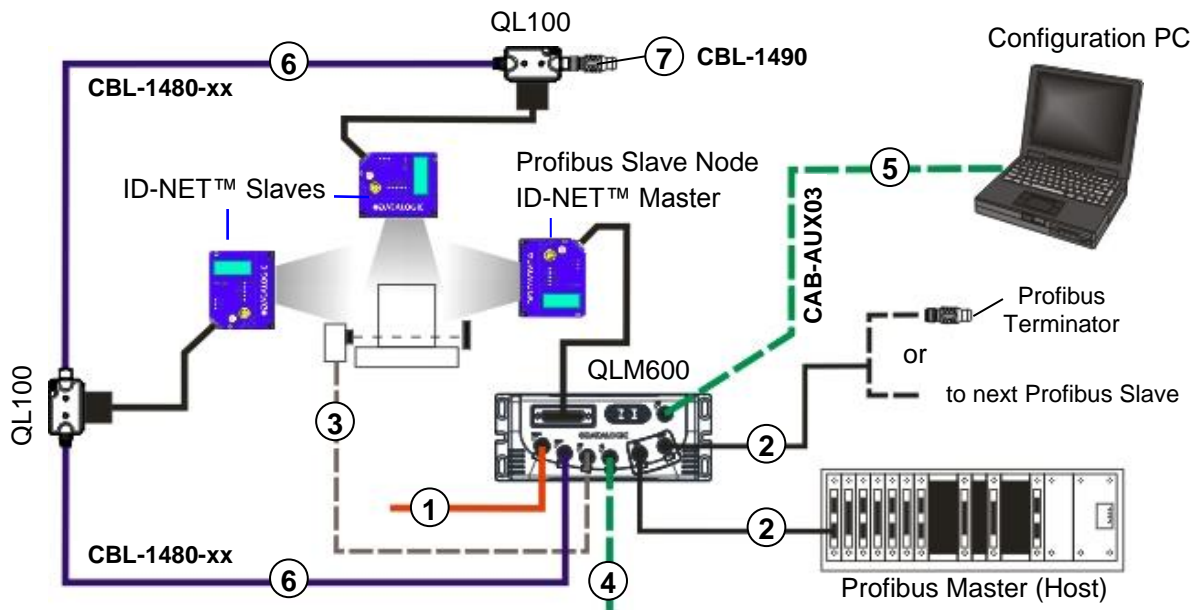

Figure 65 - ID-NET Synchronized Network – DS5100 Master with QLM600 + DS5100 Slaves with QL100s

- ① Input Power
- ② Profibus Interface
- ③ External Trigger (for On-Line Mode)
- ④ External Digital I/O Devices
- ⑤ Aux port for Reader Configuration
- ⑥ ID-NET Network
- ⑦ ID-NET Terminator



NOTE: The ID-NET network must be terminated inserting an ID-NET terminator into the last QL in the network. ID-NET on the QLM600 is internally terminated.

5.7 ID-NET MULTIDATA NETWORKS

For a Master/Slave Multidata layout each scanner has its own reading phase independent from the others; each single message is sent from the master scanner to the Host computer.

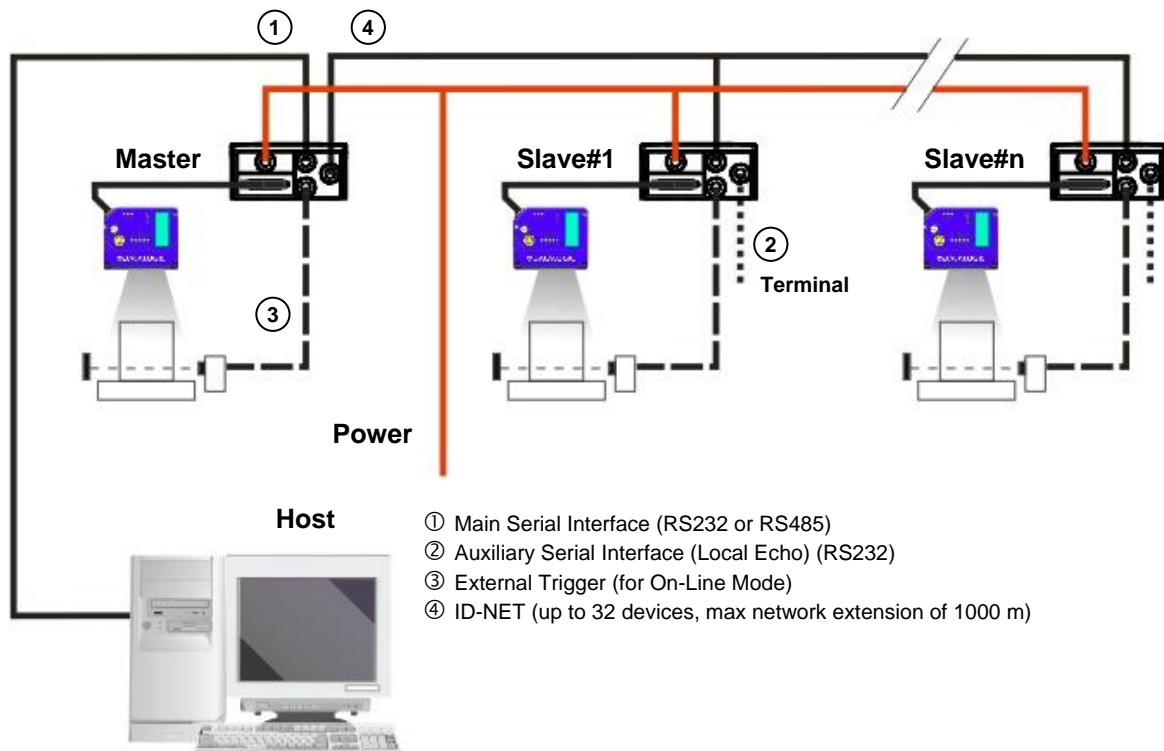

Figure 66 – ID-NET Multidata with Serial Host

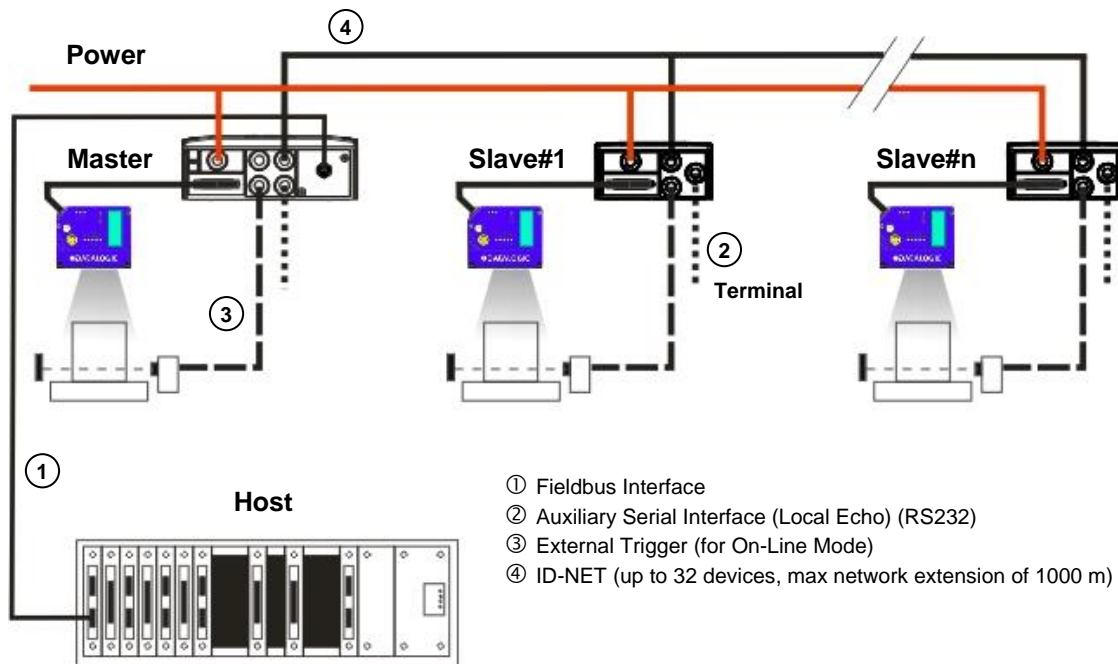

Figure 67 – ID-NET Multidata with Fieldbus Host

5.8 PASS-THROUGH

An alternative Pass-Through layout allows the more efficient ID-NET network to be used. This layout is really an ID-NET Master/Slave Multidata layout which also allows **each** scanner (Master and Slaves) to accept input on the Auxiliary interface, for example to connect a device such as a hand-held reader for manual code reading capability.

Each scanner transmits its own messages plus any messages received by its Auxiliary interface onto the ID-NET interface. The Master passes all messages to the Host.

When On-Line Operating mode is used, the scanner is activated by an External Trigger (photoelectric sensor) when the object enters its reading zone.

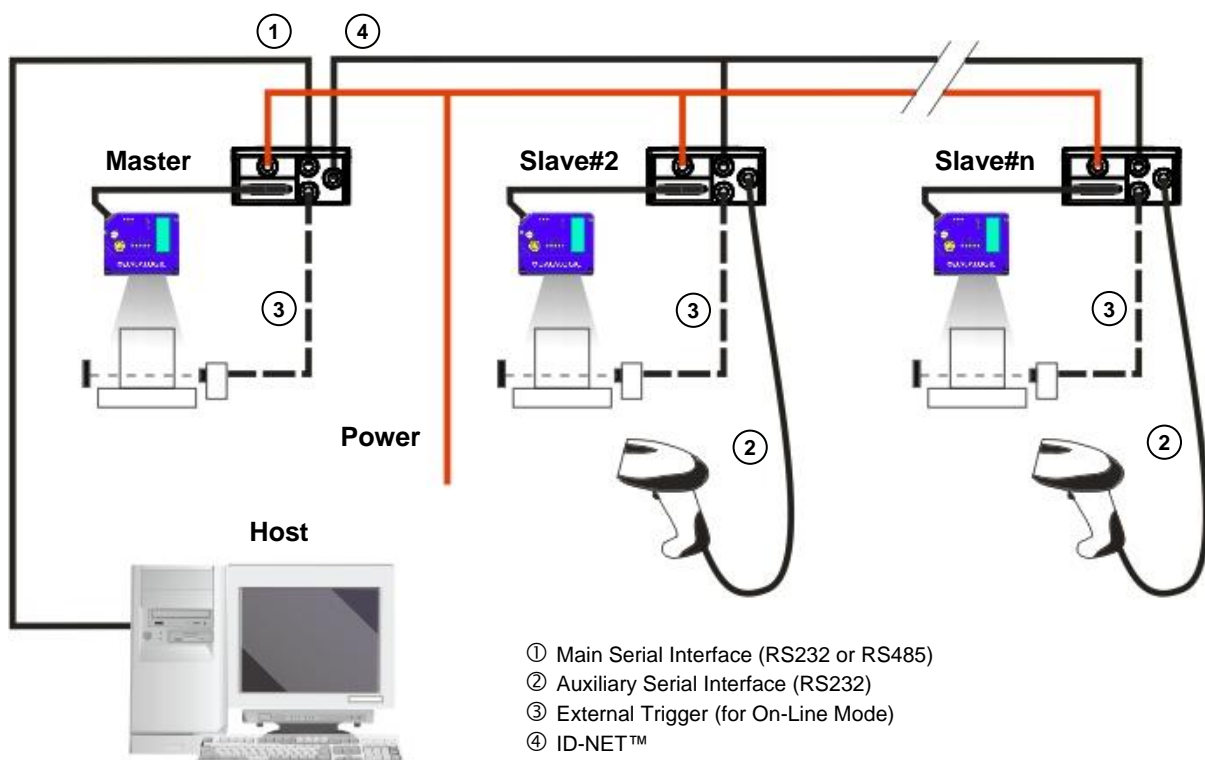

Figure 68 – Pass-Through On ID-NET Layout



NOTE: The Master scanner connected to the Host can be alternatively connected to a Fieldbus network using a Host Interface module through a CBX500 connection box.

5.9 OTHER LAYOUTS



NOTE: Other backward-compatible layouts are available such as: RS232 Master/Slave, RS232 Pass Through and Multiplexer. We recommend using the more efficient ID-NET network for Master/Slave or Multiplexer layouts.

6 READING FEATURES

6.1 ADVANCED CODE RECONSTRUCTION (ACR 4)

The traditional way of barcode reading could be called “Linear Reading”. In this case, the laser beam crosses the barcode symbol from its beginning to its end as shown in the following figure:

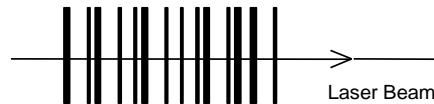

Figure 69 – Linear Reading

In Advanced Code Reconstruction mode it is no longer necessary for the laser beam to cross the label from the start to the end. With just a set of partial scans on the label (obtained using the motion of the label itself), the scanner is able to “reconstruct” the barcode. A typical set of partial scans is shown in the figure below:

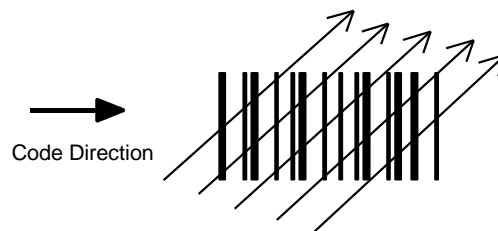

Figure 70 – Partial Scans

None of the partial scans contains the whole label. The decoder aligns each partial scan correctly and combines them in order to obtain the entire code.

The alignment is performed by calculating the time difference from one partial scan to another using a reference code element.

ACR4 therefore has an intrinsic ability to increase the reading percentage of damaged codes as in the examples below:



Figure 71 – ACR4 Readable Codes

6.1.1 Tilt Angle for Advanced Code Reconstruction

The most important parameter in Advanced Code Reconstruction is the value of the maximum tilt angle (α maximum) under which the code reconstruction process is still possible.

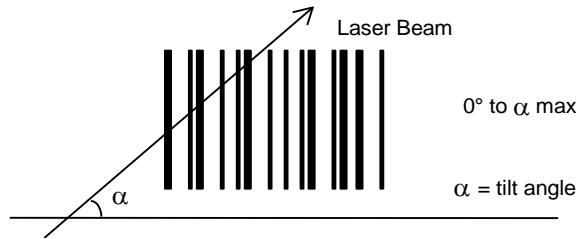

Figure 72 – Tilt Angle

The decoder will be able to read the label with a tilt angle between $+\alpha$ max and $-\alpha$ max as shown in the following figure:

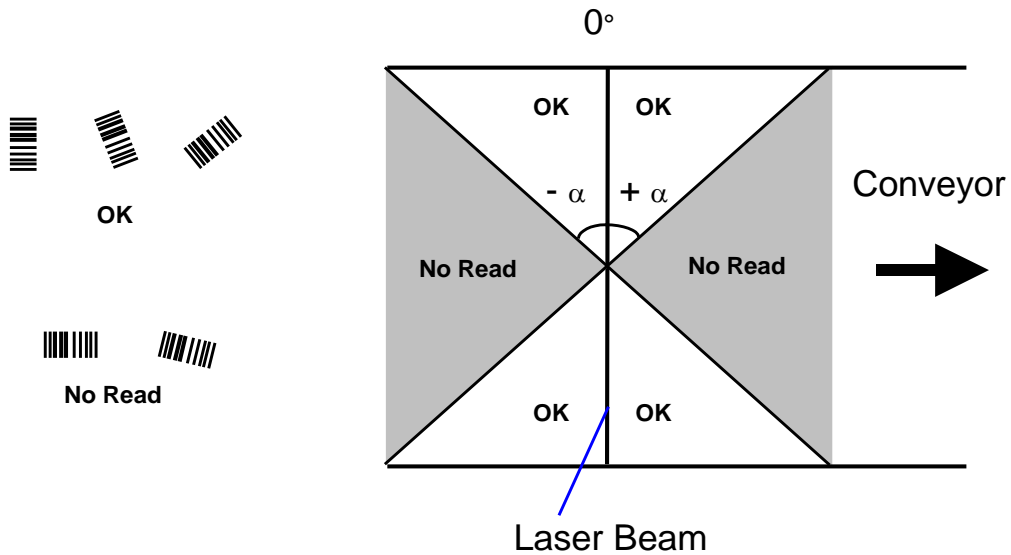

Figure 73 – Reading Zones with α Max

6.1.2 ACR Reading Conditions for Medium Range Models

The following tables describe the minimum code height requirements (in mm) for standard ACR4 applications depending on the code symbology and the given reading conditions.

- ANSI Grade B minimum

2/5 Interleaved		Minimum Code Height for ACR4 Reading (mm)											
		45° max						30° max					
Conveyor Speed (m/s)		0.5	1	1.5	2	2.5	3	0.5	1	1.5	2	2.5	3
Code Resolution (mm)	0.25	12	15	18	21	23	26	8	11	13	15	17	19
	0.30	14	16	19	22	25	28	9	11	14	16	18	20
	0.33	15	17	20	23	26	29	10	12	14	16	19	21
	0.38	16	19	22	24	27	30	11	13	15	17	20	22
	0.50	20	22	25	28	31	34	13	15	17	19	22	24
	0.72	26	29	32	35	37	40	17	19	21	23	25	28
	1.00	35	37	40	43	46	49	21	24	26	28	30	33

Ratio 3:1

Table 1

Code 39		Minimum Code Height for ACR4 Reading (mm)											
		45° max						30° max					
Conveyor Speed (m/s)		0.5	1	1.5	2	2.5	3	0.5	1	1.5	2	2.5	3
Code Resolution (mm)	0.25	11	14	16	19	22	25	8	10	12	14	16	19
	0.30	12	15	18	20	23	26	8	10	13	15	17	19
	0.33	13	16	18	21	24	27	9	11	13	15	18	20
	0.38	14	17	20	22	25	28	9	12	14	16	18	21
	0.50	17	20	22	25	28	31	11	13	16	18	20	22
	0.72	22	25	28	31	33	36	14	16	19	21	23	25
	1.00	29	32	35	37	40	43	18	20	23	25	27	29

Ratio 3:1; Interdigit = Module Size

Table 2

Code 128 – GS1-128		Minimum Code Height for ACR4 Reading (mm)											
		45° max						30° max					
Conveyor Speed (m/s)		0.5	1	1.5	2	2.5	3	0.5	1	1.5	2	2.5	3
Code Resolution (mm)	0.25	9	12	15	18	21	23	7	9	11	13	16	18
	0.30	10	13	16	19	22	24	7	9	12	14	16	18
	0.33	11	14	16	19	22	25	8	10	12	14	17	19
	0.38	12	15	17	20	23	26	8	10	13	15	17	19
	0.50	14	17	20	22	25	28	9	12	14	16	18	21
	0.72	18	21	24	27	29	32	12	14	16	19	21	23
	1.00	24	26	29	32	35	38	15	17	19	22	24	26

Table 3

Codabar		Minimum Code Height for ACR4 Reading (mm)											
		45° max						30° max					
Conveyor Speed (m/s)		0.5	1	1.5	2	2.5	3	0.5	1	1.5	2	2.5	3
Code Resolution (mm)	0.25	10	12	15	18	21	24	7	9	11	14	16	18
	0.30	11	13	16	19	22	25	7	10	12	14	16	19
	0.33	11	14	17	20	22	26	8	10	12	14	17	19
	0.38	12	15	18	21	23	26	8	11	13	15	17	20
	0.50	15	17	20	23	26	29	10	12	14	16	19	21
	0.72	19	22	25	27	30	33	12	15	17	19	21	24
	1.00	25	27	30	33	36	39	16	18	20	22	25	27

Ratio 3:1; Interdigit = Module Size

Table 4

EAN 8-13, UPC-A		Minimum Code Height for ACR4 Reading (mm)											
		45° max						30° max					
Conveyor Speed (m/s)		0.5	1	1.5	2	2.5	3	0.5	1	1.5	2	2.5	3
Code Resolution (mm)	0.25	9	12	15	18	21	23	7	9	11	13	16	18
	0.30	10	13	16	19	22	24	7	9	12	14	16	18
	0.33	11	14	16	19	22	25	8	10	12	14	17	19
	0.38	12	15	17	20	23	26	8	10	13	15	17	19
	0.50	14	17	20	22	25	28	9	12	14	16	18	21
	0.72	18	21	24	27	29	32	12	14	16	19	21	23
	1.00	24	26	29	32	35	38	15	17	19	22	24	26

Table 5



NOTE: To maximize scanner performance in Advanced Code Reconstruction Reading applications:

- enable only the code symbologies that will actually be used in the application and disable any code symbologies that will not be used in the application
- reconstruct only one code label at a time

6.1.3 ACR Reading Conditions for Long Range Models

The following tables describe the minimum code height requirements (in mm) for standard ACR4 applications depending on the code symbology and the given reading conditions.

- ANSI Grade B minimum

2/5 Interleaved		Minimum Code Height for ACR4 Reading (mm)											
		45° max						30° max					
Conveyor Speed (m/s)		0.5	1	1.5	2	2.5	3	0.5	1	1.5	2	2.5	3
Code Resolution (mm)	0.25	10	11	13	14	16	17	7	8	9	10	12	13
	0.30	12	13	14	16	17	19	8	9	10	11	12	14
	0.33	12	14	15	17	18	20	8	9	10	12	13	14
	0.38	14	15	16	18	19	21	9	10	11	12	14	15
	0.50	18	18	20	21	23	24	11	12	13	14	15	17
	0.72	24	25	26	27	28	30	15	16	16	18	19	20
	1.00	33	33	34	35	36	37	20	20	21	22	23	24

Ratio 3:1

Table 6

Code 39		Minimum Code Height for ACR4 Reading (mm)											
		45° max						30° max					
Conveyor Speed (m/s)		0.5	1	1.5	2	2.5	3	0.5	1	1.5	2	2.5	3
Code Resolution (mm)	0.25	9	9	11	12	14	15	6	7	8	9	10	11
	0.30	10	11	12	13	15	16	7	7	8	10	11	12
	0.33	11	11	12	14	15	17	7	8	9	10	11	12
	0.38	12	13	13	15	16	18	8	8	9	10	12	13
	0.50	15	16	16	17	18	20	9	10	11	12	13	14
	0.72	20	21	22	22	23	24	13	13	14	14	15	16
	1.00	27	28	29	29	30	31	17	17	18	18	19	20

Ratio 3:1; Interdigit = Module Size

Table 7

Code 128 – GS1-128		Minimum Code Height for ACR4 Reading (mm)											
		45° max						30° max					
Conveyor Speed (m/s)		0.5	1	1.5	2	2.5	3	0.5	1	1.5	2	2.5	3
Code Resolution (mm)	0.25	7	9	10	12	13	15	6	6	8	9	10	11
	0.30	8	9	11	12	14	15	6	7	8	9	10	12
	0.33	9	10	11	13	14	16	6	7	8	9	11	12
	0.38	10	11	12	14	15	17	6	8	9	10	11	12
	0.50	12	13	14	16	17	19	8	9	10	11	12	13
	0.72	16	17	18	19	21	22	10	11	12	13	14	15
	1.00	21	22	23	24	25	26	13	14	15	16	17	18

Table 8

Codabar		Minimum Code Height for ACR4 Reading (mm)											
		45° max						30° max					
Conveyor Speed (m/s)		0.5	1	1.5	2	2.5	3	0.5	1	1.5	2	2.5	3
Code Resolution (mm)	0.25	8	9	10	12	13	15	5	6	8	9	10	11
	0.30	9	9	11	12	14	15	6	7	8	9	10	12
	0.33	9	10	11	13	14	16	6	7	8	9	11	12
	0.38	10	11	12	14	15	17	7	8	9	10	11	12
	0.50	13	13	14	16	17	19	8	9	10	11	12	13
	0.72	17	18	18	19	21	22	11	11	12	13	14	15
	1.00	23	23	24	25	26	26	14	15	15	16	17	18

Ratio 3:1; Interdigit = Module Size

Table 9

EAN 8-13, UPC-A		Minimum Code Height for ACR4 Reading (mm)											
		45° max						30° max					
Conveyor Speed (m/s)		0.5	1	1.5	2	2.5	3	0.5	1	1.5	2	2.5	3
Code Resolution (mm)	0.25	7	8	9	11	12	14	5	6	7	8	9	11
	0.30	8	9	10	11	13	14	6	6	7	9	10	11
	0.33	9	10	10	12	13	15	6	7	8	9	10	11
	0.38	10	11	11	12	14	15	6	7	8	9	10	12
	0.50	12	13	14	14	15	17	8	8	9	10	11	12
	0.72	16	17	18	18	19	20	10	11	11	12	13	14
	1.00	21	22	23	24	24	25	13	14	15	15	16	16

Table 10



NOTE: To maximize scanner performance in Advanced Code Reconstruction Reading applications:

- enable only the code symbologies that will actually be used in the application and disable any code symbologies that will not be used in the application
- reconstruct only one code label at a time

6.2 LINEAR CODE READING

The number of scans performed on the code by the scanner and therefore the decoding capability is influenced by the following parameters:

- number of scans per second
- code motion speed
- label dimensions
- scan direction with respect to code motion

At least 5 scans during the code passage should be allowed to ensure a successful read.

6.2.1 Step-Ladder Mode

If scanning is perpendicular to the code motion direction (Figure 74), the number of effective scans performed by the reader is given by the following formula:

$$SN = [(LH/LS) * SS] - 2$$

Where: SN = number of effective scans
 LH = label height (in mm)
 LS = label movement speed in (mm/s)
 SS = number of scans per second

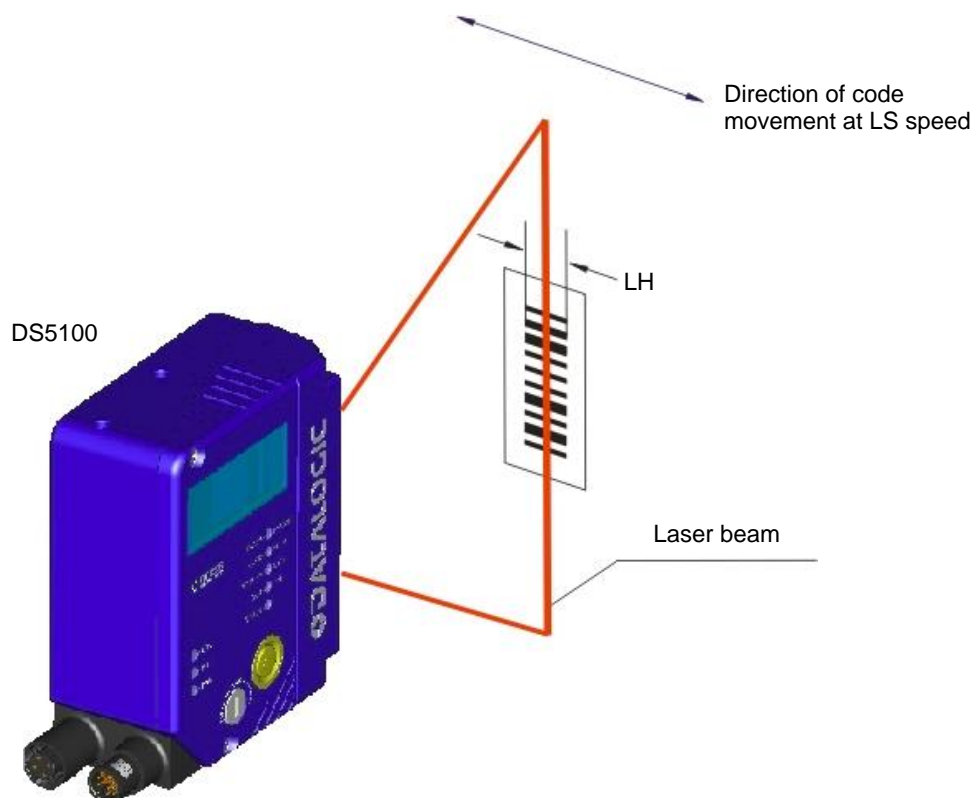

Figure 74 - "Step-Ladder" Scanning Mode

For example, the DS5100 (800 scans/sec.) for a 25 mm high code moving at 1250 mm/s performs:

$$[(25/1250) * 800] - 2 = 14 \text{ effective scans.}$$

6.2.2 Picket-Fence Mode

If scanning is parallel to the code motion, (Figure 75), the number of effective scans is given by the following formula:

$$SN = [((FW-LW)/LS) * SS] - 2$$

Where:

- SN = number of effective scans
- FW = reading field width (in mm)
- LW = label width (in mm)
- LS = label movement speed (in mm/s)
- SS = scans per second

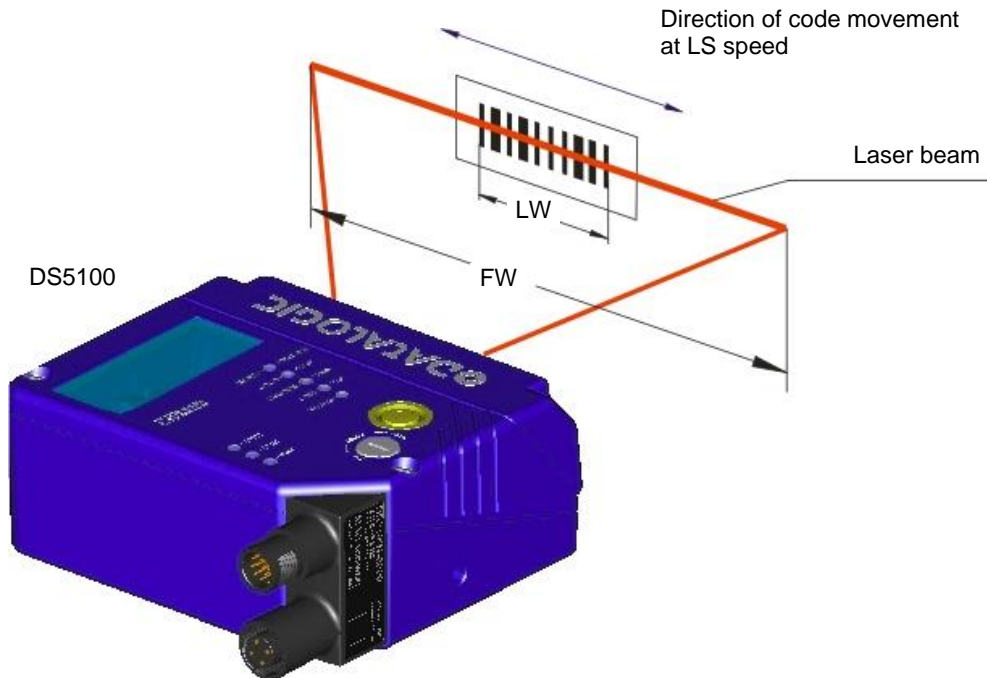

Figure 75 - "Picket-Fence" Scanning Mode

For example, for a 60 mm wide code moving in a point where the reading field is 160 mm wide at a 2000 mm/s speed, the DS5100 (800 scans per sec.), performs:

$$[((160-60)/2000) * 800] - 2 = 38 \text{ effective scans}$$

6.3 PERFORMANCE

The reading performance of the DS5100 scanner depends in part on the focus position setting.

1x00 (Linear Medium Range Models)		
Focus	Max Code Resolution	Reading Distance on 0.50 mm (20 mils) codes
F = 30 Near	0.20 mm (8 mils)	20 cm (7.9 in) - 50 cm (19.7 in)
F = 40 Med	0.25 mm (10 mils)	25 cm (9.8 in) - 70 cm (27.6 in)
F = 60 Far	0.38 mm (15 mils)	40 cm (15.7 in) - 100 cm (39.4 in)

1x05 (Linear Medium Range Subzero Models)		
Focus	Max Code Resolution	Reading Distance on 0.50 mm (20 mils) codes
F = 30 Near	0.20 mm (8 mils)	22 cm (8.7 in) - 50 cm (19.7 in)
F = 40 Med	0.25 mm (10 mils)	27 cm (10.6 in) - 68 cm (26.8 in)
F = 60 Far	0.38 mm (15 mils)	41 cm (16.1 in) - 96 cm (37.8 in)

2x00 (Linear Long Range Models)		
Focus	Max Code Resolution	Reading Distance on 0.50 mm (20 mils) codes
F = 45 Near	0.25 mm (10 mils)	30 cm (11.8 in) - 72 cm (28.3 in)
F = 65 Med	0.30 mm (12 mils)	45 cm (17.7 in) - 110 cm (43.3 in)
F = 75 Far	0.38 mm (15 mils)	58 cm (22.8 in) - 140 cm (55.1 in)

1x20 (OM Medium Range Models)		
Focus	Max Code Resolution	Reading Distance on 0.50 mm (20 mils) codes
F = 30 Near	0.20 mm (8 mils)	18 cm (7.1 in) - 47 cm (18.5 in)
F = 40 Med	0.25 mm (10 mils)	23 cm (9.1 in) - 67 cm (26.4 in)
F = 60 Far	0.38 mm (15 mils)	39 cm (15.4 in) - 95 cm (37.4 in)

1x25 (OM Medium Range Subzero Models)		
Focus	Max Code Resolution	Reading Distance on 0.50 mm (20 mils) codes
F = 30 Near	0.20 mm (8 mils)	20 cm (7.9 in) - 47 cm (18.5 in)
F = 40 Med	0.25 mm (10 mils)	25 cm (9.8 in) - 65 cm (25.6 in)
F = 60 Far	0.38 mm (15 mils)	40 cm (15.7 in) - 90 cm (35.4 in)

2x20 (OM Long Range Models)		
Focus	Max Code Resolution	Reading Distance on 0.50 mm (20 mils) codes
F = 45 Near	0.25 mm (10 mils)	28 cm (11.0 in) - 69 cm (27.2 in)
F = 65 Med	0.30 mm (12 mils)	43 cm (16.9 in) - 107 cm (42.1 in)
F = 75 Far	0.38 mm (15 mils)	55 cm (21.7 in) - 135 cm (53.2 in)

Refer to the diagrams in par. 6.4 for further details on the reading features.

For Standard and OM models, these diagrams are taken on various resolution sample codes at a 25 °C ambient temperature and depend on the conditions listed under each diagram.

Subzero model diagrams are based on an ambient temperature of -35 °C and depend on the conditions listed under each diagram.

6.4 READING DIAGRAMS

6.4.1 Linear Medium Range Models

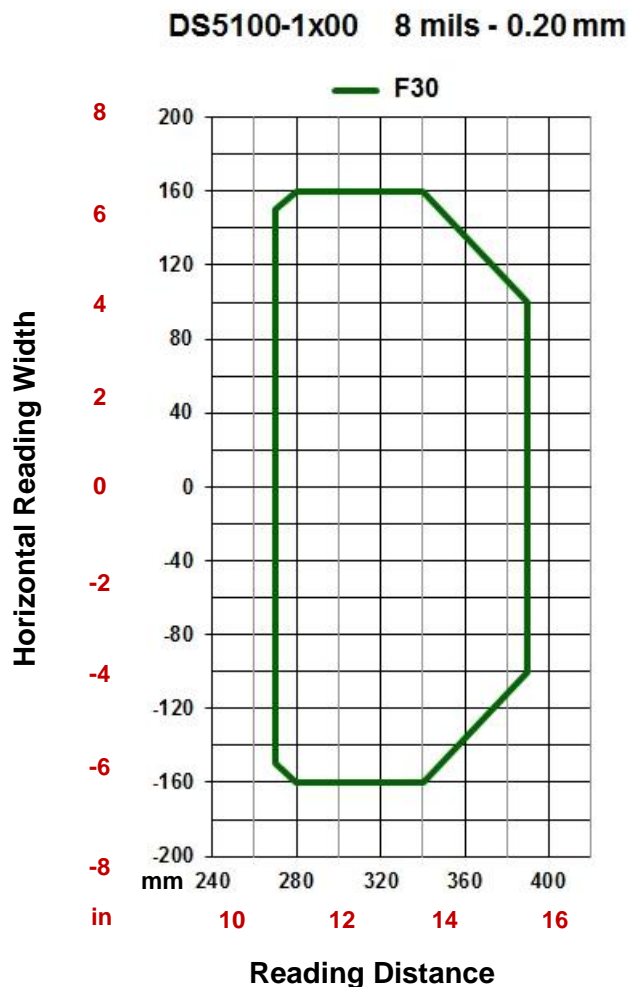

NOTE: (0,0) is the center of the laser beam output window.

CONDITIONS

Hardware Settings	
Code Symbology	Code 128
PCS	0.90
"Pitch" angle	0°
"Skew" angle	15°
"Tilt" angle	0°
Software Parameters	
Reading Mode	Linear

For Tilt angles of 45°, the reading performance is reduced by approximately 10%.

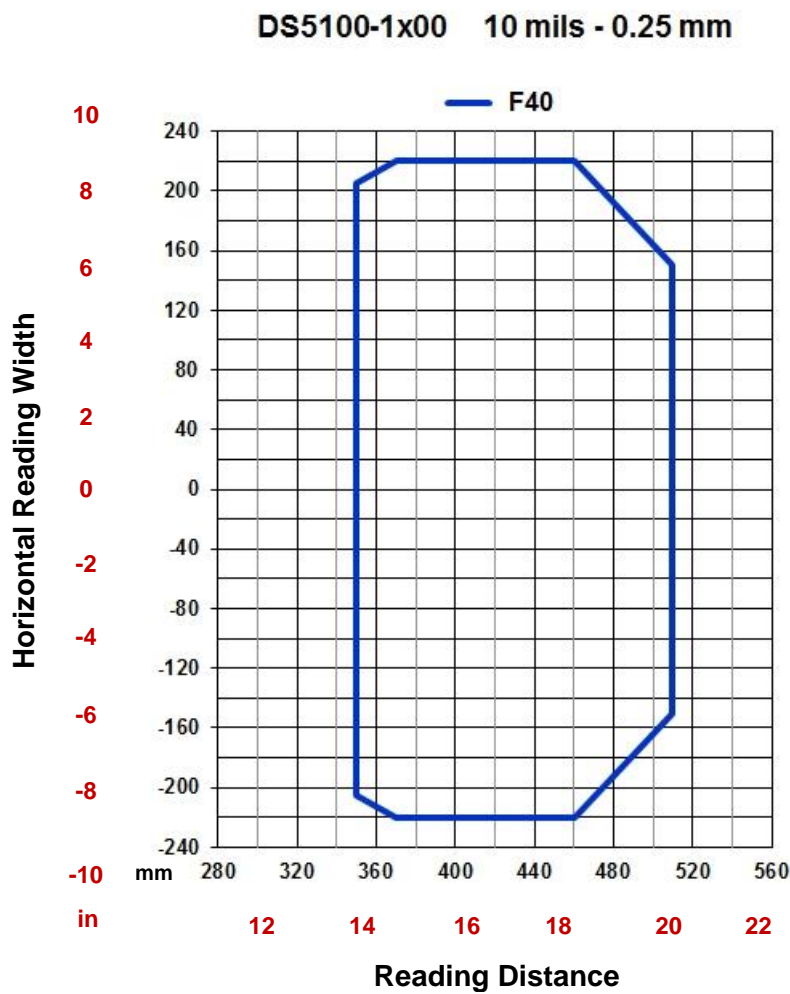

NOTE: (0,0) is the center of the laser beam output window.

CONDITIONS

Hardware Settings	
Code Symbology	Code 128
PCS	0.90
"Pitch" angle	0°
"Skew" angle	15°
"Tilt" angle	0°
Software Parameters	
Reading Mode	Linear

For Tilt angles of 45°, the reading performance is reduced by approximately 10%.

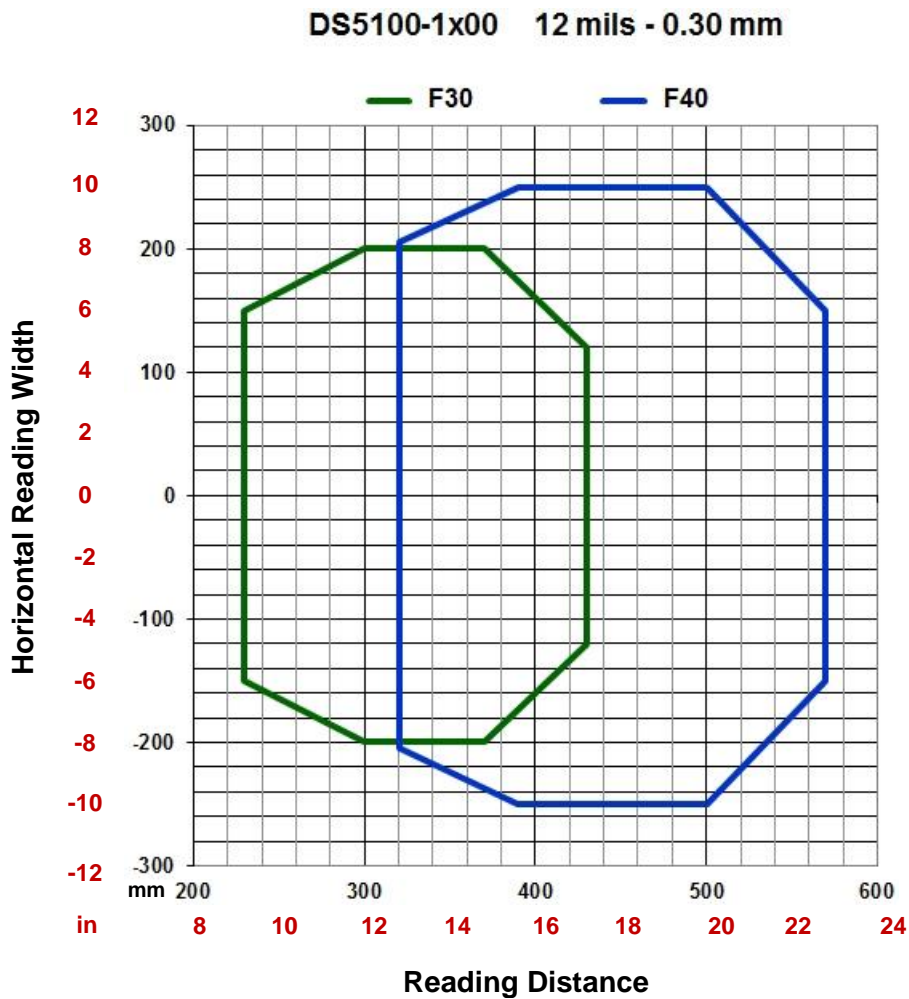

NOTE: (0,0) is the center of the laser beam output window.

CONDITIONS

Hardware Settings	
Code Symbology	Code 128
PCS	0.90
"Pitch" angle	0°
"Skew" angle	15°
"Tilt" angle	0°
Software Parameters	
Reading Mode	Linear

For Tilt angles of 45°, the reading performance is reduced by approximately 10%.

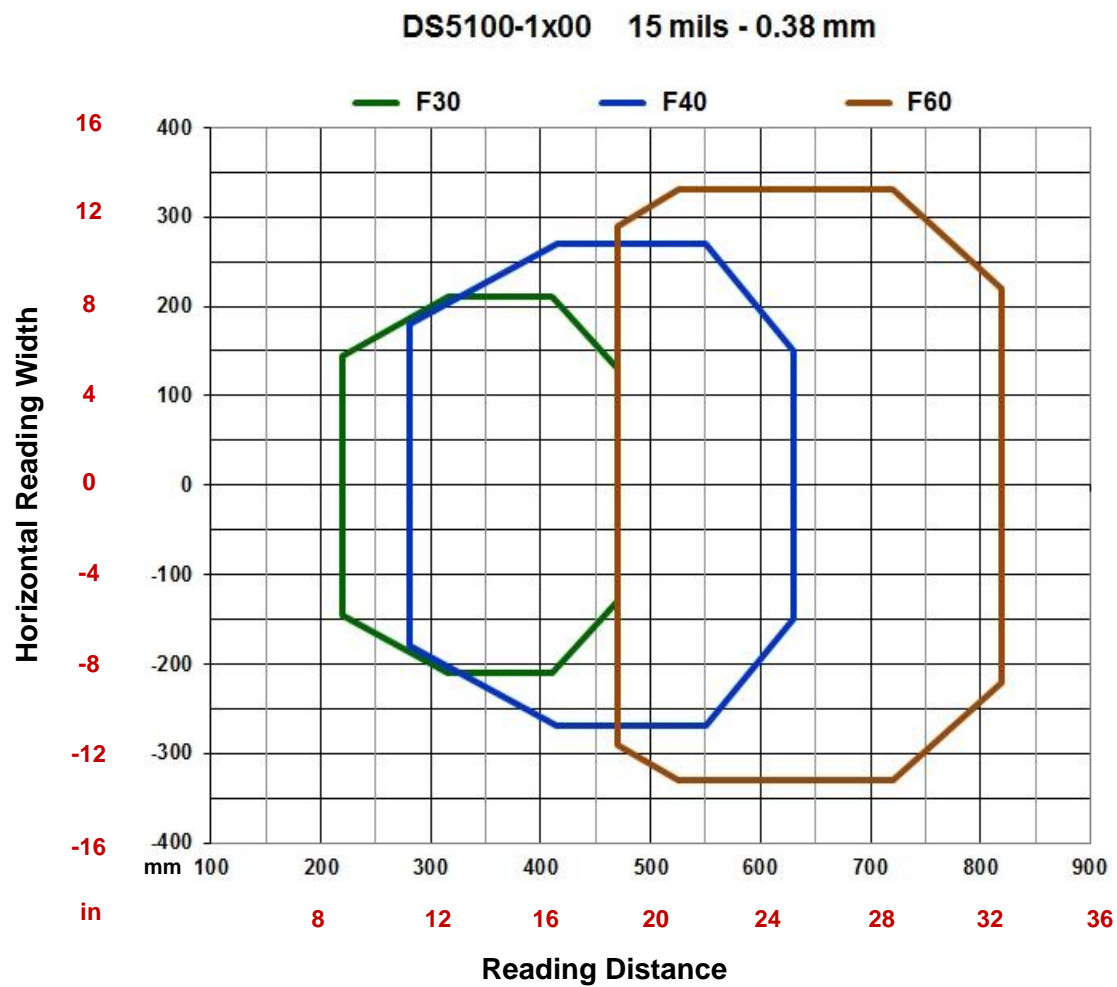

NOTE: (0,0) is the center of the laser beam output window.

CONDITIONS

Hardware Settings	
Code Symbology	Code 128
PCS	0.90
"Pitch" angle	0°
"Skew" angle	15°
"Tilt" angle	0°
Software Parameters	
Reading Mode	Linear

For Tilt angles of 45°, the reading performance is reduced by approximately 10%.

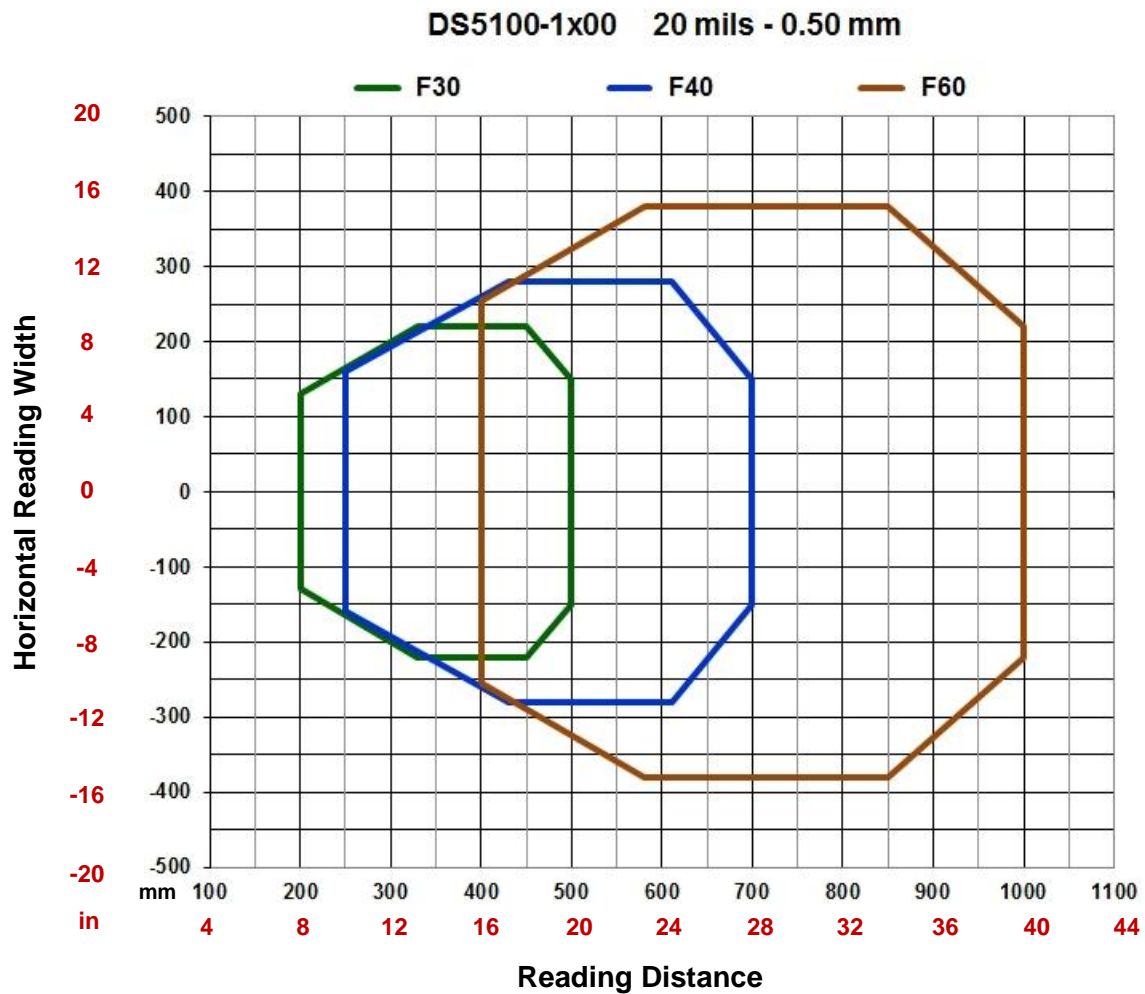

NOTE: (0,0) is the center of the laser beam output window.

CONDITIONS

Hardware Settings	
Code Symbology	Code 128
PCS	0.90
"Pitch" angle	0°
"Skew" angle	15°
"Tilt" angle	0°
Software Parameters	
Reading Mode	Linear

For Tilt angles of 45°, the reading performance is reduced by approximately 10%.

6.4.2 Linear Medium Range Subzero Models

DS5100-1x05 8 mils - 0.20 mm



NOTE: (0,0) is the center of the laser beam output window.

CONDITIONS

Hardware Settings	
Code Symbology	Code 128
PCS	0.90
"Pitch" angle	0°
"Skew" angle	15°
"Tilt" angle	0°
Software Parameters	
Reading Mode	Linear

For Tilt angles of 45°, the reading performance is reduced by approximately 10%.

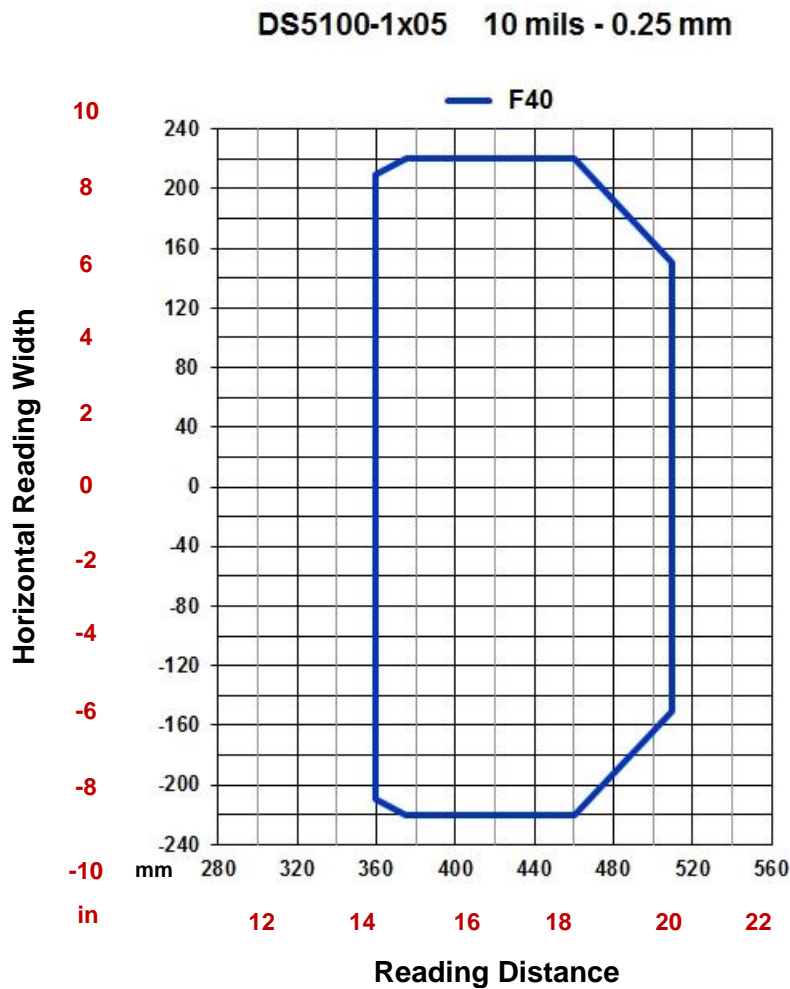

NOTE: (0,0) is the center of the laser beam output window.

CONDITIONS

Hardware Settings	
Code Symbology	Code 128
PCS	0.90
"Pitch" angle	0°
"Skew" angle	15°
"Tilt" angle	0°
Software Parameters	
Reading Mode	Linear

For Tilt angles of 45°, the reading performance is reduced by approximately 10%.

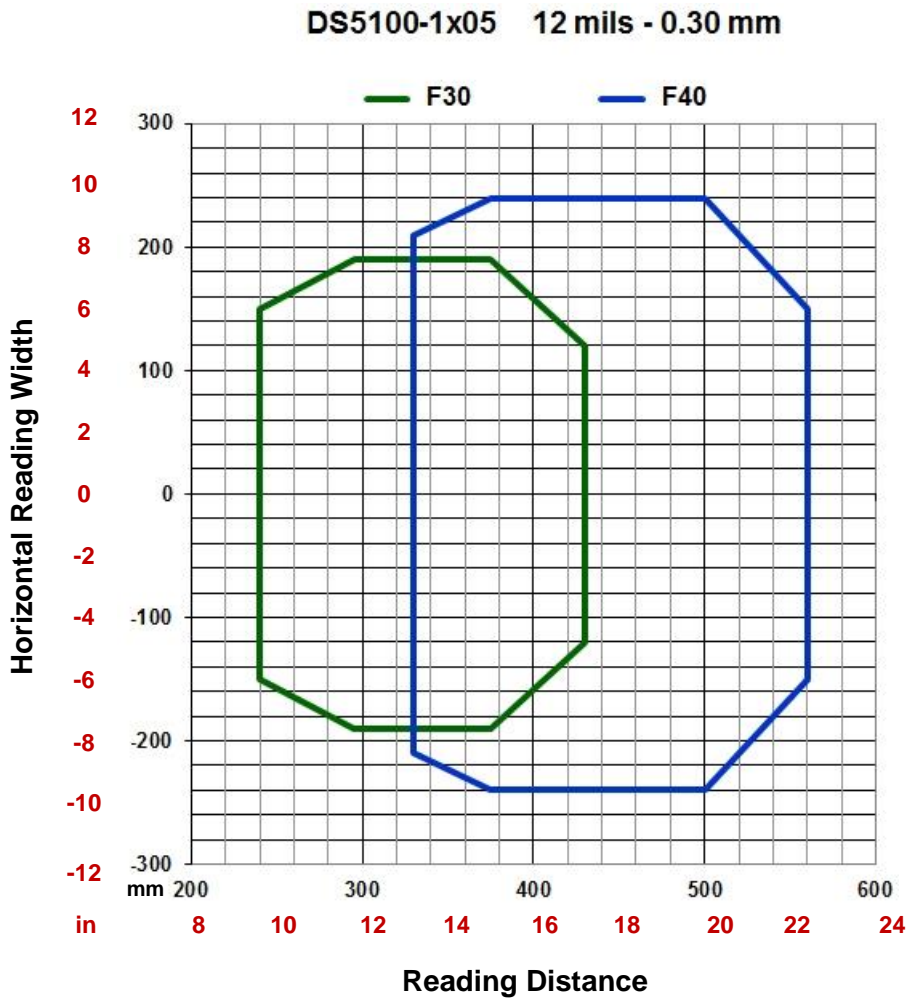

NOTE: (0,0) is the center of the laser beam output window.

CONDITIONS

Hardware Settings	
Code Symbology	Code 128
PCS	0.90
"Pitch" angle	0°
"Skew" angle	15°
"Tilt" angle	0°
Software Parameters	
Reading Mode	Linear

For Tilt angles of 45°, the reading performance is reduced by approximately 10%.

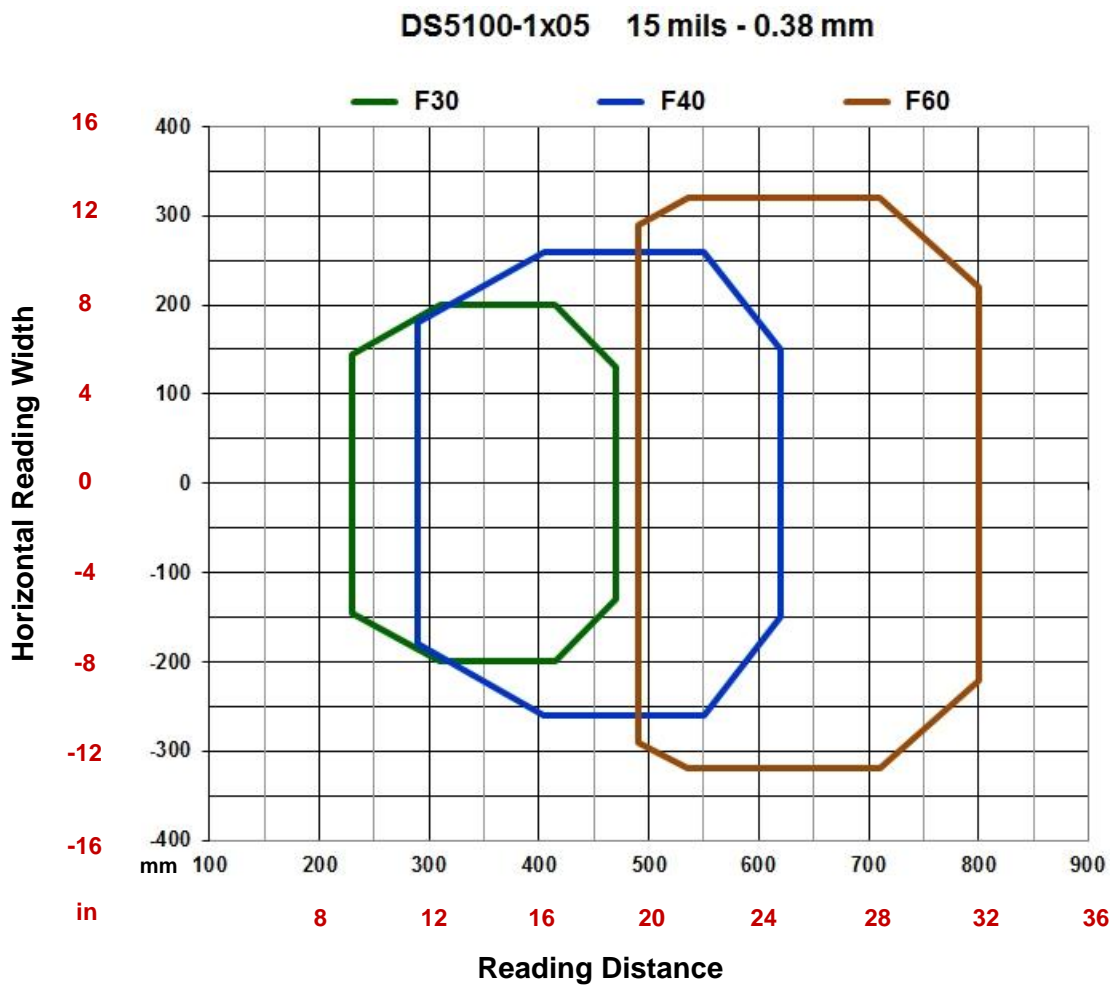

NOTE: (0,0) is the center of the laser beam output window.

CONDITIONS

Hardware Settings	
Code Symbology	Code 128
PCS	0.90
"Pitch" angle	0°
"Skew" angle	15°
"Tilt" angle	0°
Software Parameters	
Reading Mode	Linear

For Tilt angles of 45°, the reading performance is reduced by approximately 10%.

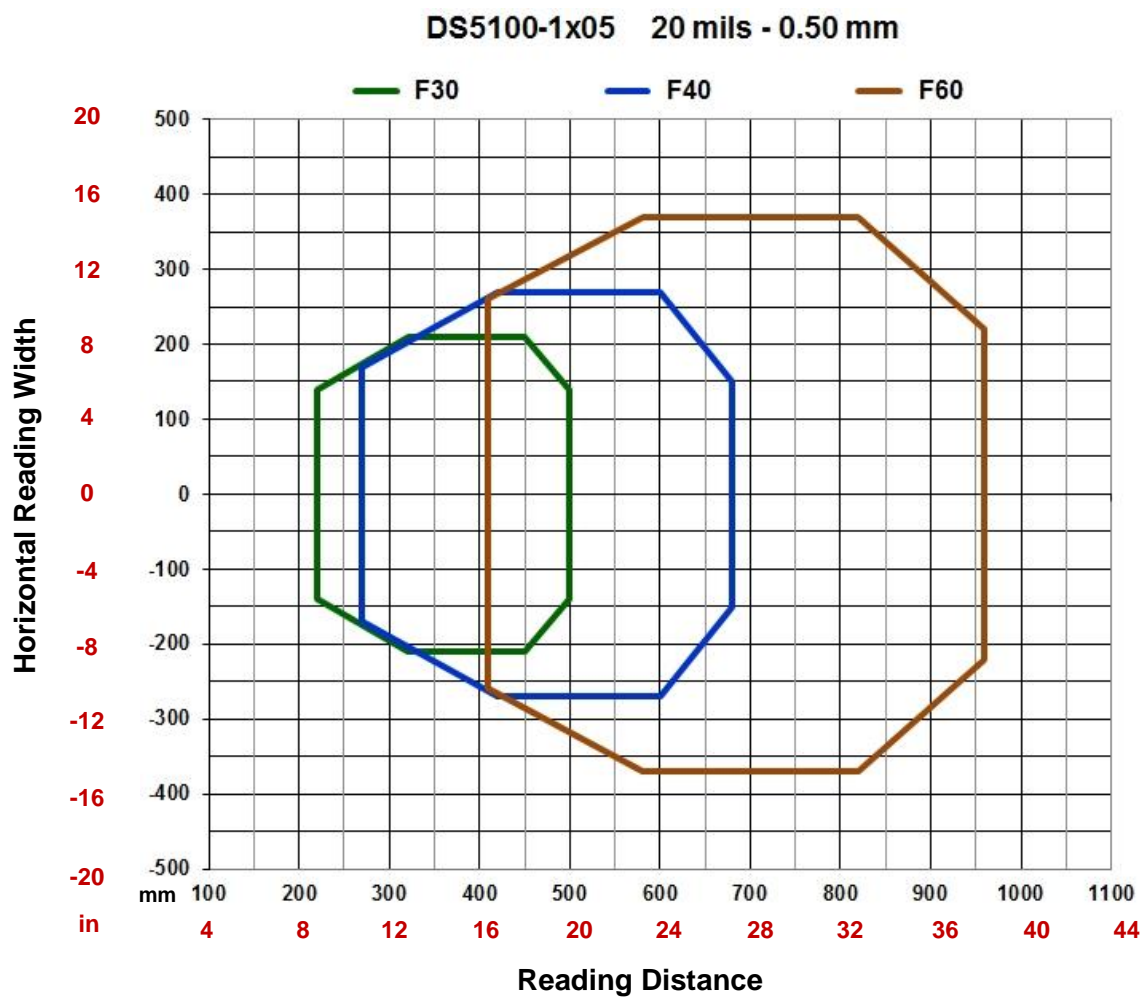

NOTE: (0,0) is the center of the laser beam output window.

CONDITIONS

Hardware Settings	
Code Symbology	Code 128
PCS	0.90
"Pitch" angle	0°
"Skew" angle	15°
"Tilt" angle	0°
Software Parameters	
Reading Mode	Linear

For Tilt angles of 45°, the reading performance is reduced by approximately 10%.

6.4.3 Linear Long Range Models

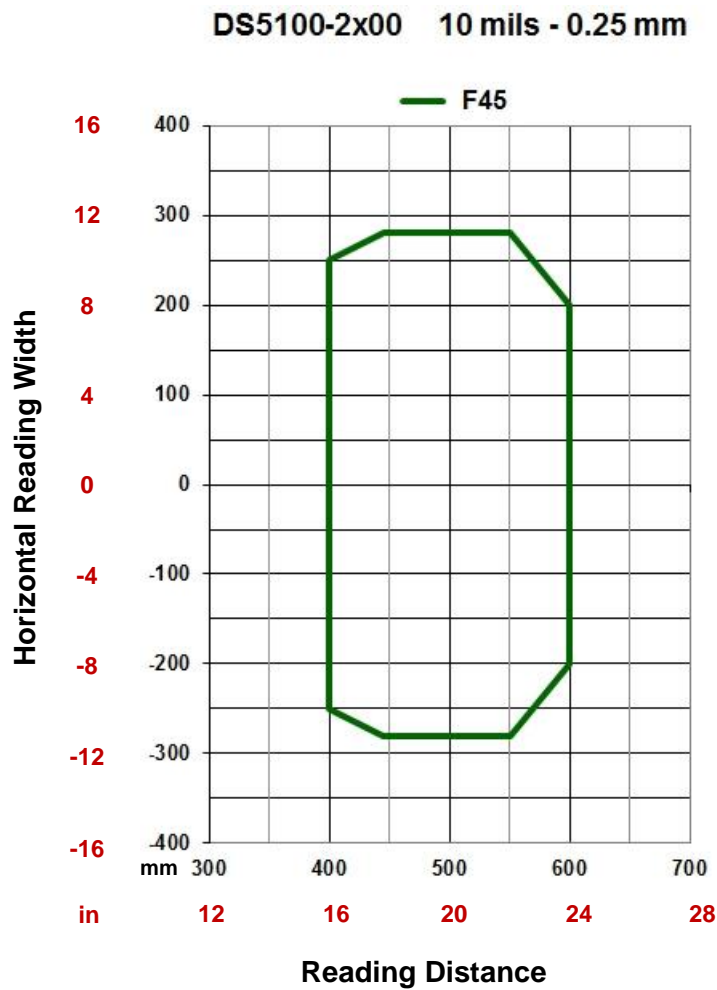

NOTE: (0,0) is the center of the laser beam output window.

CONDITIONS

Hardware Settings	
Code Symbology	Code 128
PCS	0.90
"Pitch" angle	0°
"Skew" angle	15°
"Tilt" angle	±45°
Software Parameters	
Reading Mode	Linear

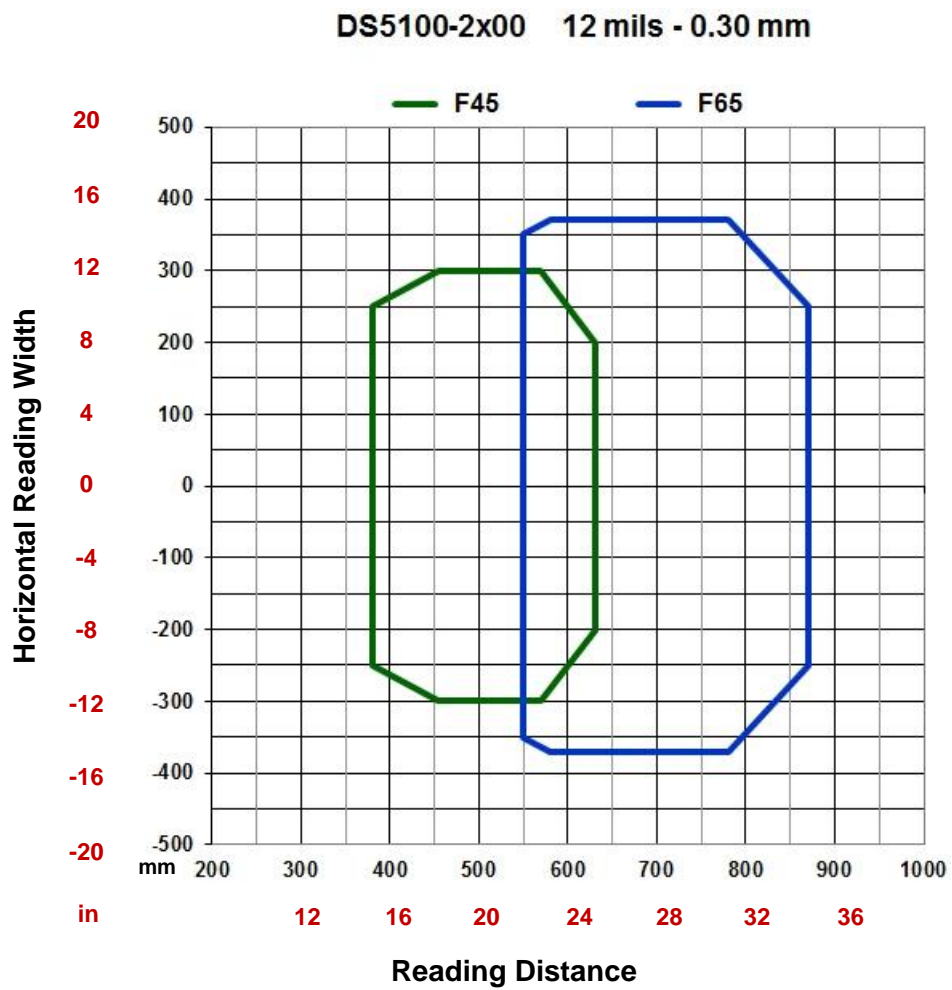

NOTE: (0,0) is the center of the laser beam output window.

CONDITIONS

Hardware Settings	
Code Symbology	Code 128
PCS	0.90
"Pitch" angle	0°
"Skew" angle	15°
"Tilt" angle	±45°
Software Parameters	
Reading Mode	Linear

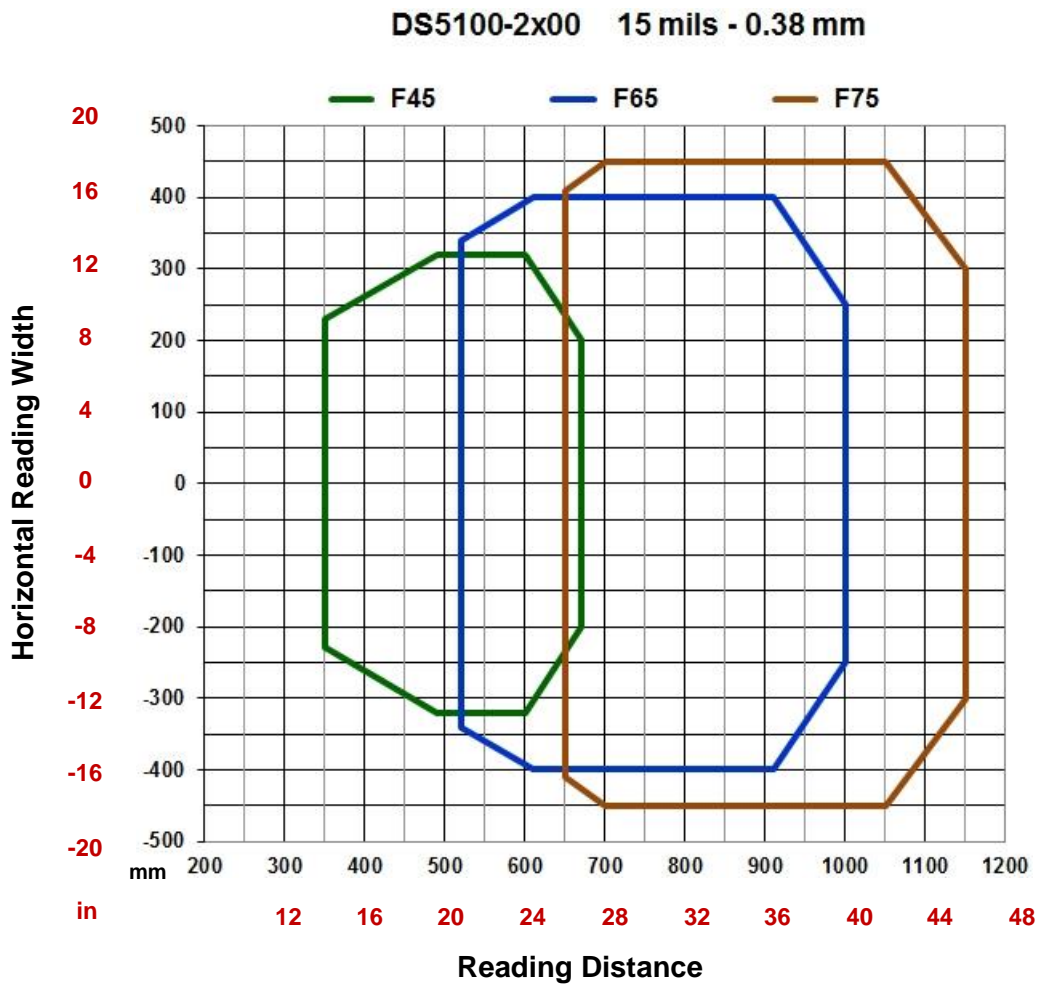

NOTE: (0,0) is the center of the laser beam output window.

CONDITIONS

Hardware Settings	
Code Symbology	Code 128
PCS	0.90
"Pitch" angle	0°
"Skew" angle	15°
"Tilt" angle	±45°
Software Parameters	
Reading Mode	Linear

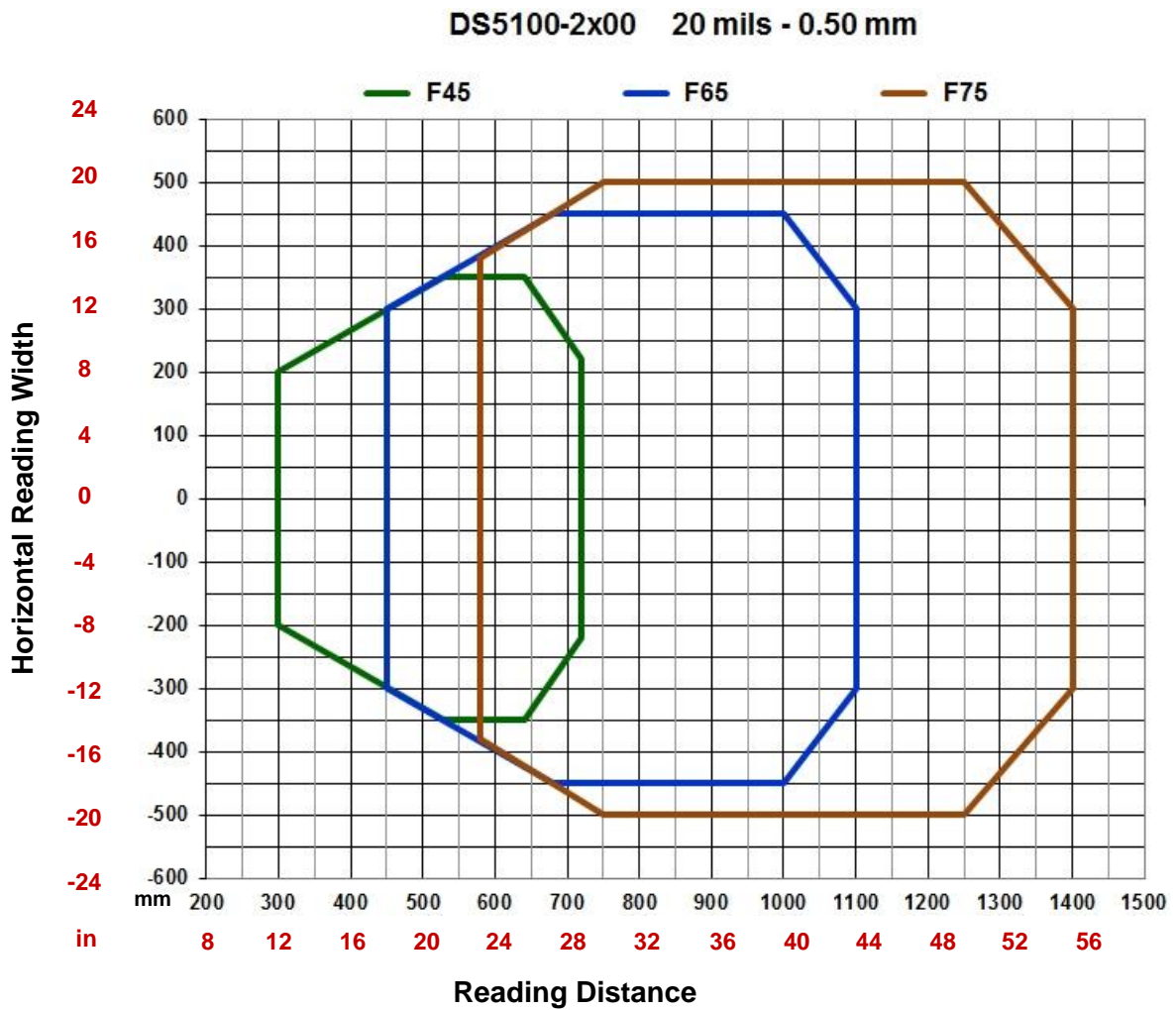

NOTE: (0,0) is the center of the laser beam output window.

CONDITIONS

Hardware Settings	
Code Symbology	Code 128
PCS	0.90
"Pitch" angle	0°
"Skew" angle	15°
"Tilt" angle	±45°
Software Parameters	
Reading Mode	Linear

6.4.4 Oscillating Mirror Medium Range Models

DS5100-1x20 8 mils - 0.20 mm

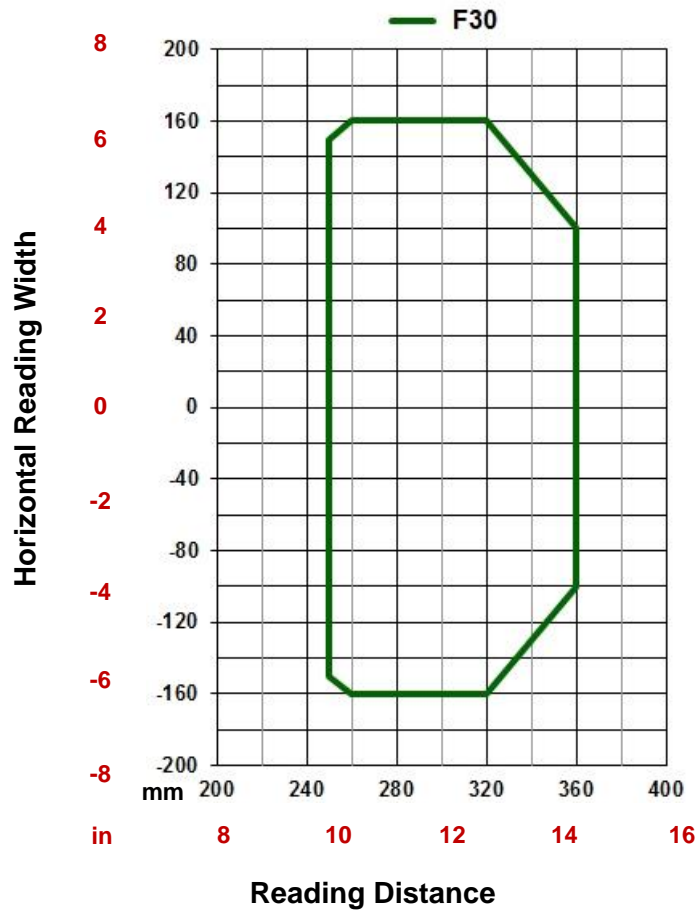

NOTE: (0,0) is the center of the laser beam output window.

CONDITIONS

Hardware Settings	
Code Symbology	Code 128
PCS	0.90
"Pitch" angle	0°
"Skew" angle	15°
"Tilt" angle	0°
Software Parameters	
Reading Mode	Linear

For Tilt angles of 45°, the reading performance is reduced by approximately 10%.

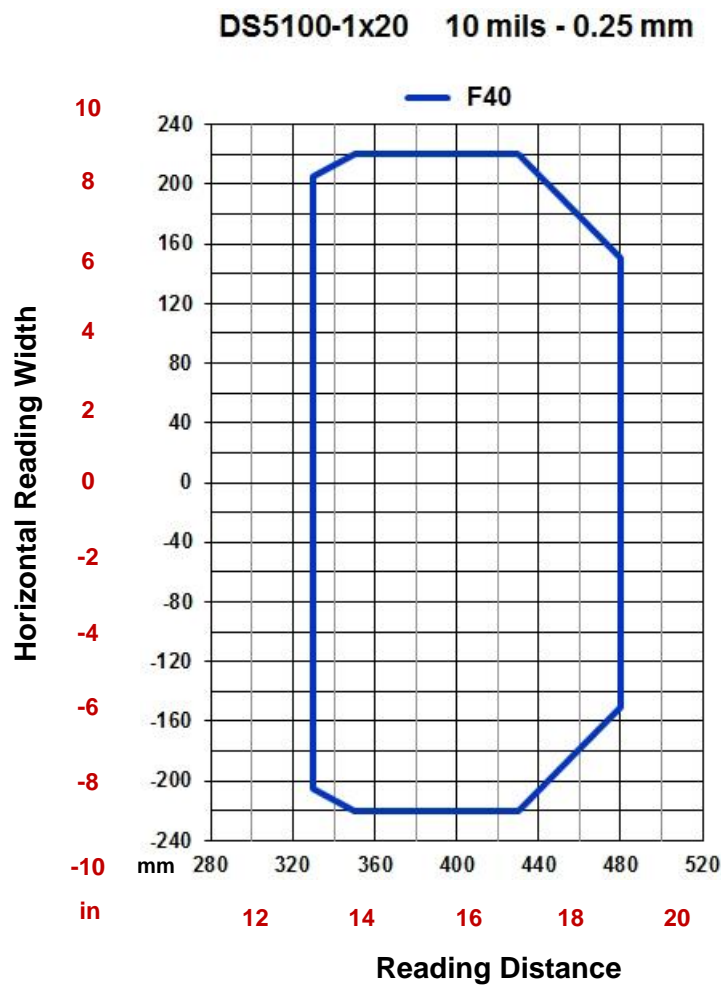

NOTE: (0,0) is the center of the laser beam output window.

CONDITIONS

Hardware Settings	
Code Symbology	Code 128
PCS	0.90
"Pitch" angle	0°
"Skew" angle	15°
"Tilt" angle	0°
Software Parameters	
Reading Mode	Linear

For Tilt angles of 45°, the reading performance is reduced by approximately 10%.

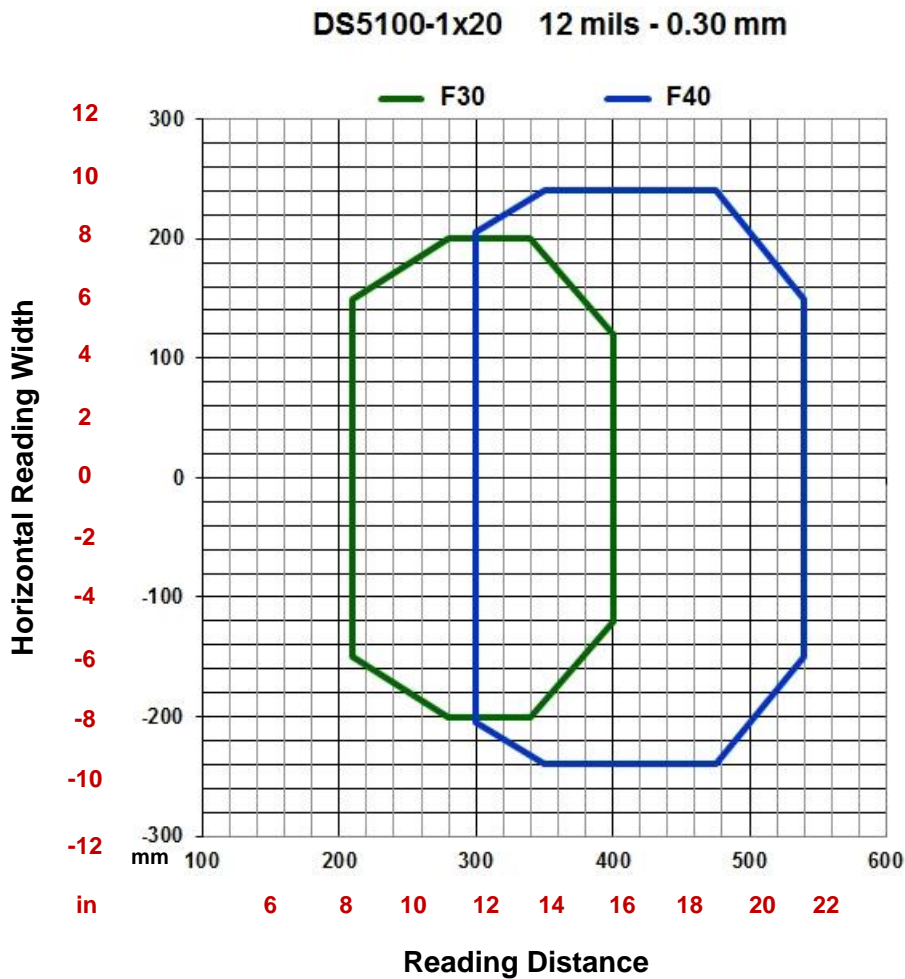

NOTE: (0,0) is the center of the laser beam output window.

CONDITIONS

Hardware Settings	
Code Symbology	Code 128
PCS	0.90
"Pitch" angle	0°
"Skew" angle	15°
"Tilt" angle	0°
Software Parameters	
Reading Mode	Linear

For Tilt angles of 45°, the reading performance is reduced by approximately 10%.

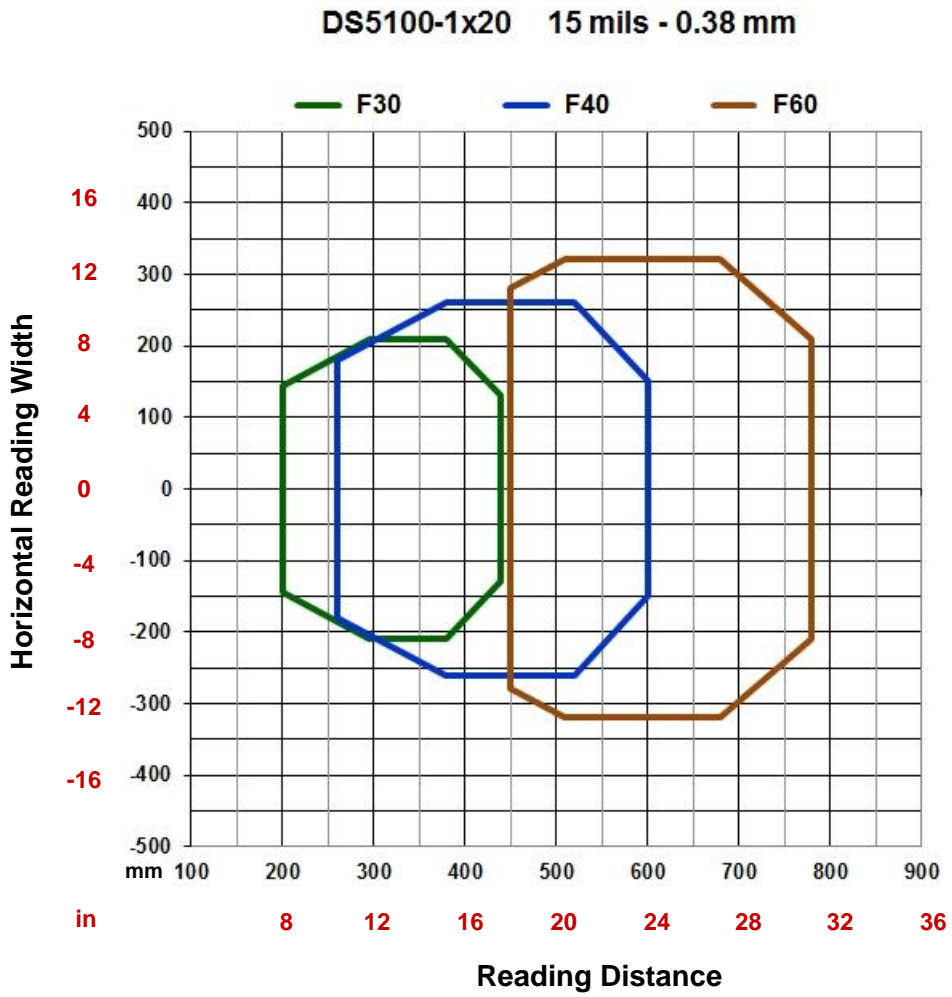

NOTE: (0,0) is the center of the laser beam output window.

CONDITIONS

Hardware Settings	
Code Symbology	Code 128
PCS	0.90
"Pitch" angle	0°
"Skew" angle	15°
"Tilt" angle	0°
Software Parameters	
Reading Mode	Linear

For Tilt angles of 45°, the reading performance is reduced by approximately 10%.

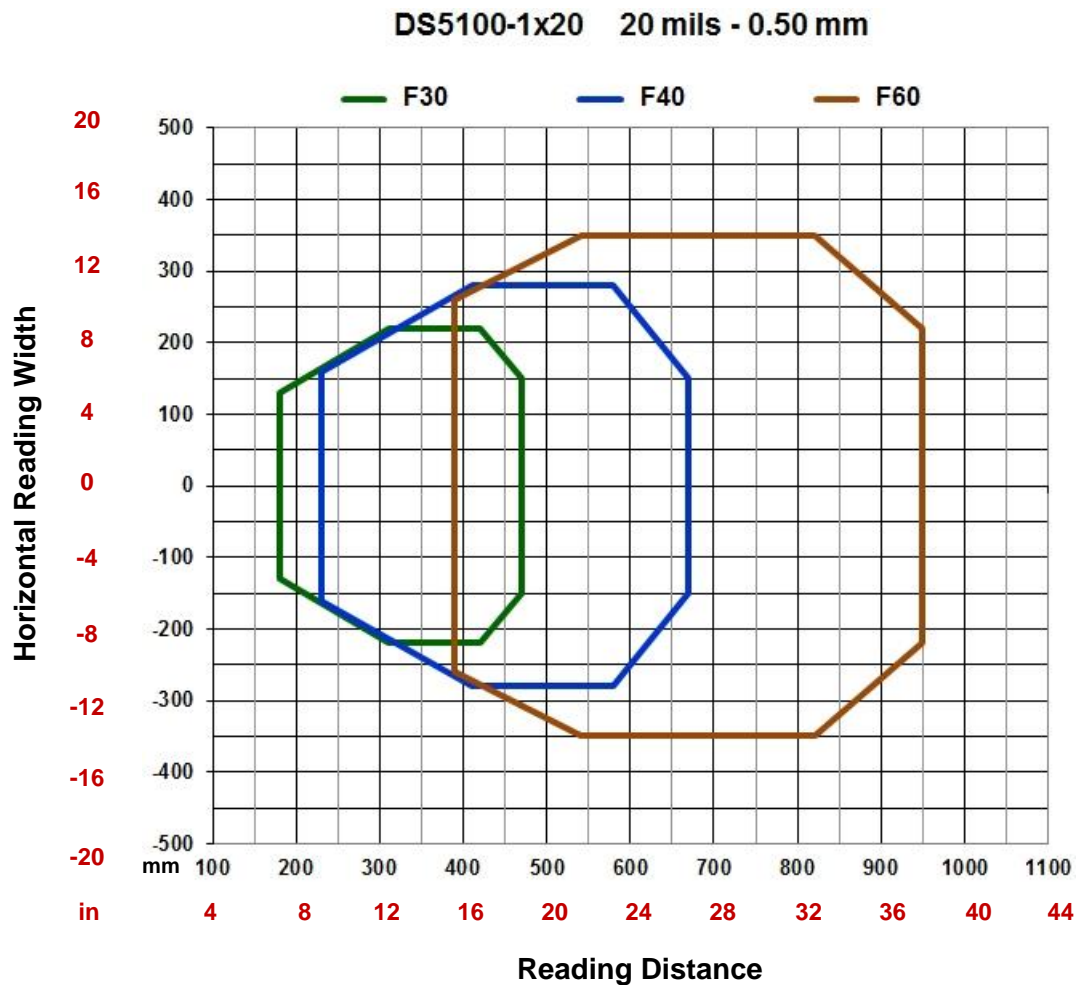

NOTE: (0,0) is the center of the laser beam output window.

CONDITIONS

Hardware Settings	
Code Symbology	Code 128
PCS	0.90
"Pitch" angle	0°
"Skew" angle	15°
"Tilt" angle	0°
Software Parameters	
Reading Mode	Linear

For Tilt angles of 45°, the reading performance is reduced by approximately 10%.

6.4.5 Oscillating Mirror Medium Range Subzero Models

DS5100-1x25 8 mils - 0.20 mm

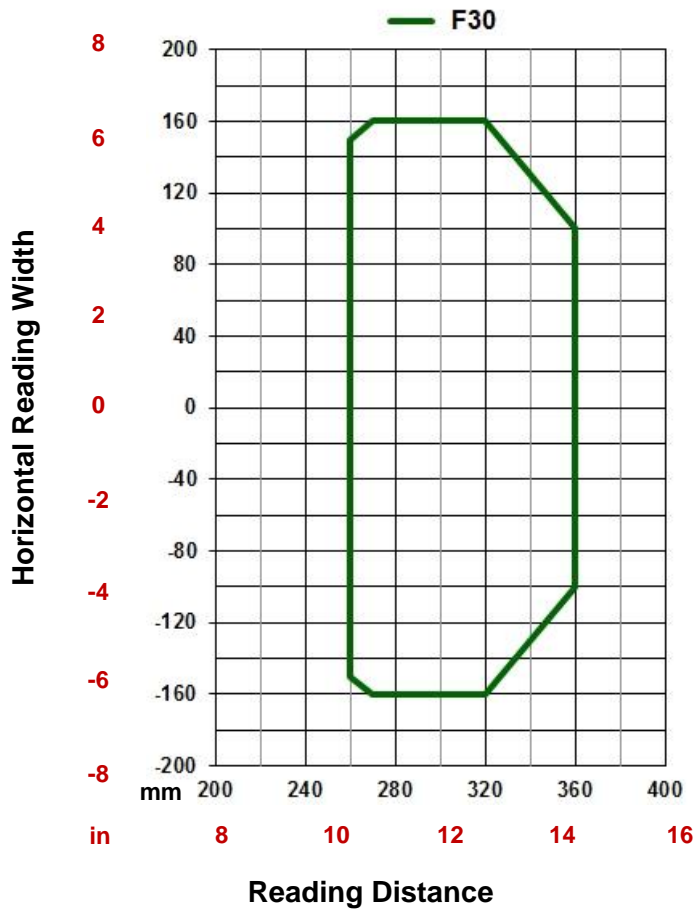

NOTE: (0,0) is the center of the laser beam output window.

CONDITIONS

Hardware Settings	
Code Symbology	Code 128
PCS	0.90
"Pitch" angle	0°
"Skew" angle	15°
"Tilt" angle	0°
Software Parameters	
Reading Mode	Linear

For Tilt angles of 45°, the reading performance is reduced by approximately 10%.

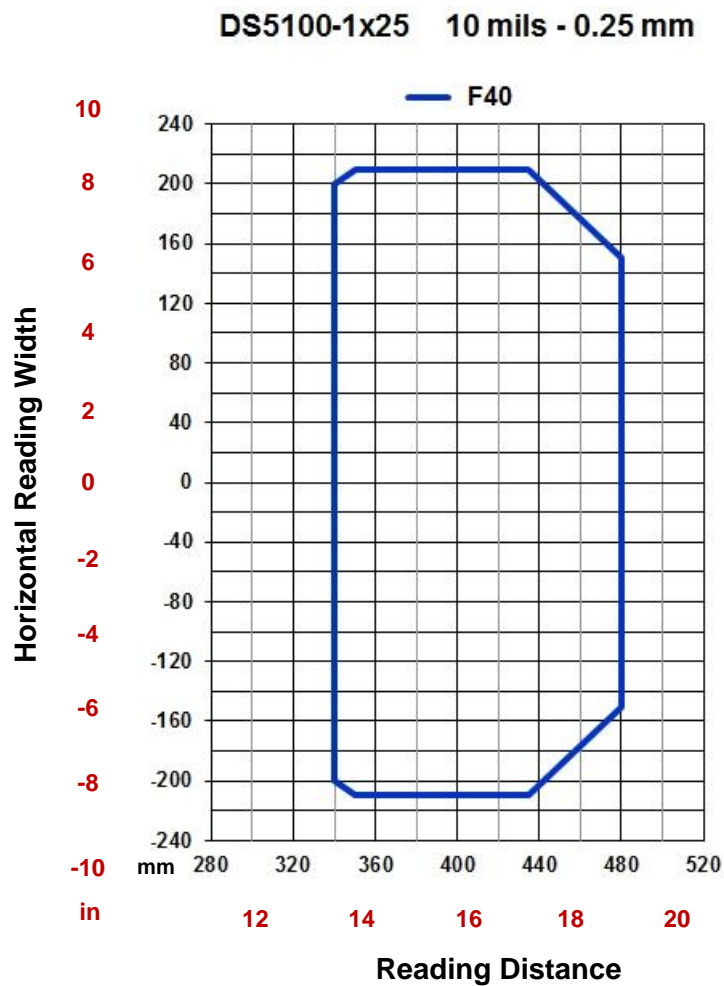

NOTE: (0,0) is the center of the laser beam output window.

CONDITIONS

Hardware Settings	
Code Symbology	Code 128
PCS	0.90
"Pitch" angle	0°
"Skew" angle	15°
"Tilt" angle	0°
Software Parameters	
Reading Mode	Linear

For Tilt angles of 45°, the reading performance is reduced by approximately 10%.

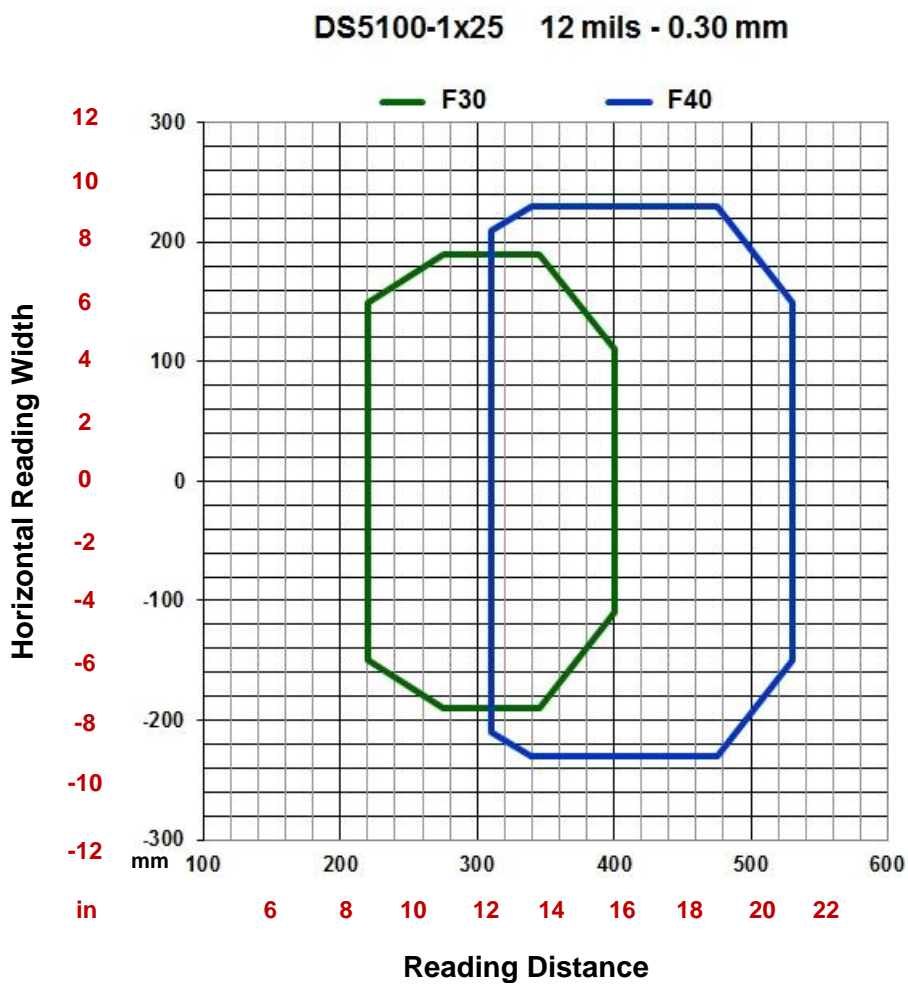

NOTE: (0,0) is the center of the laser beam output window.

CONDITIONS

Hardware Settings	
Code Symbology	Code 128
PCS	0.90
"Pitch" angle	0°
"Skew" angle	15°
"Tilt" angle	0°
Software Parameters	
Reading Mode	Linear

For Tilt angles of 45°, the reading performance is reduced by approximately 10%.

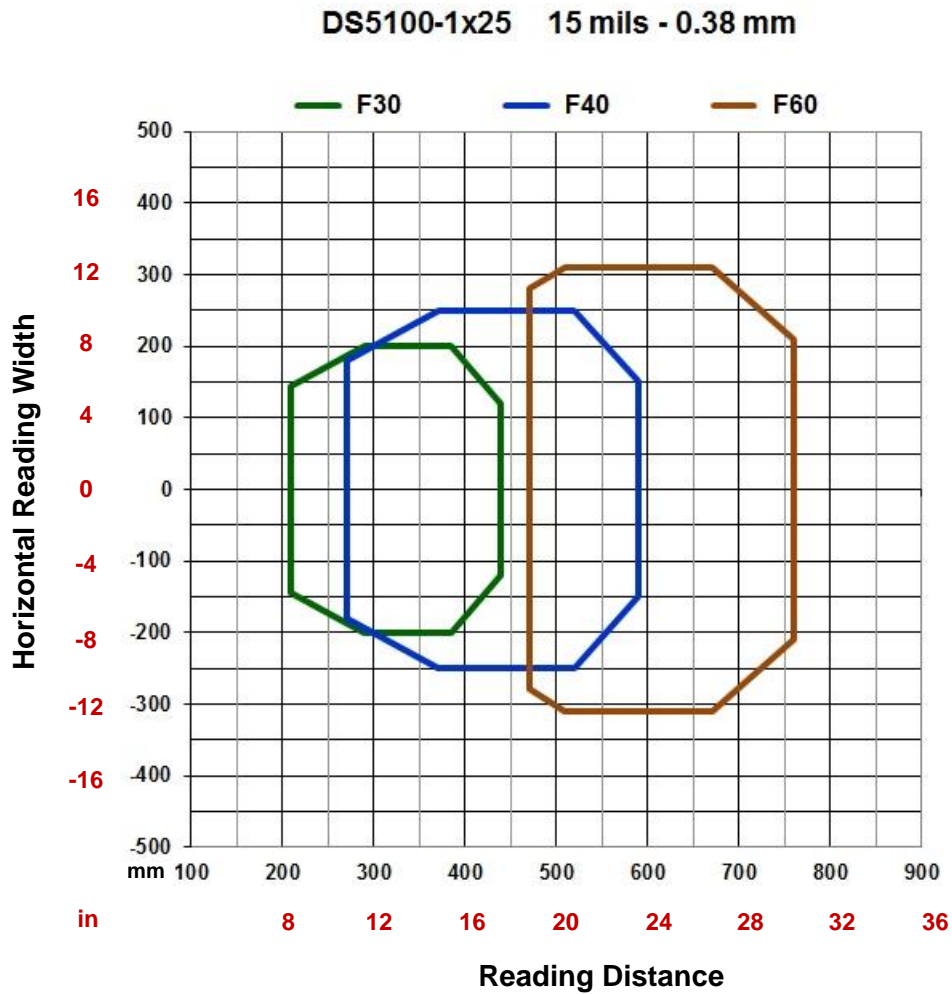

NOTE: (0,0) is the center of the laser beam output window.

CONDITIONS

Hardware Settings	
Code Symbology	Code 128
PCS	0.90
"Pitch" angle	0°
"Skew" angle	15°
"Tilt" angle	0°
Software Parameters	
Reading Mode	Linear

For Tilt angles of 45°, the reading performance is reduced by approximately 10%.

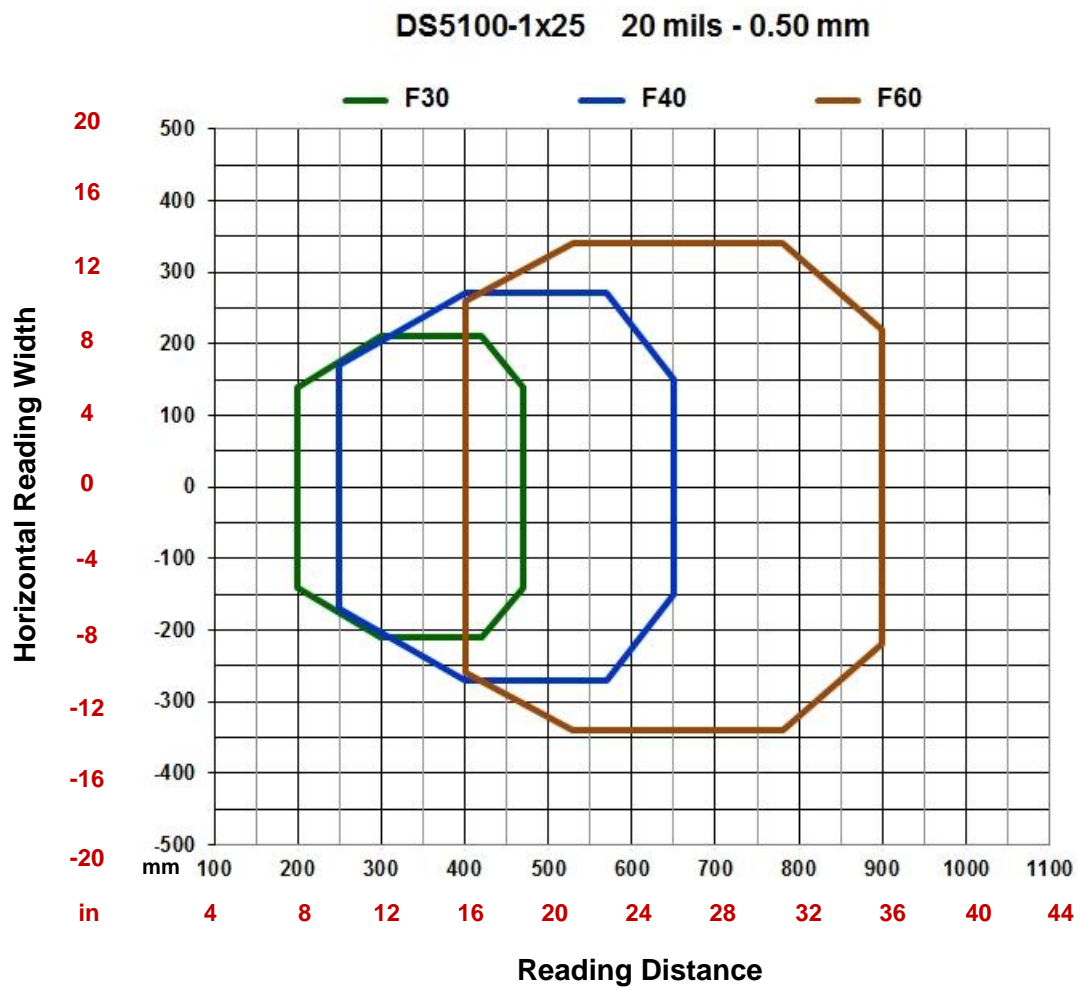

NOTE: (0,0) is the center of the laser beam output window.

CONDITIONS

Hardware Settings	
Code Symbology	Code 128
PCS	0.90
"Pitch" angle	0°
"Skew" angle	15°
"Tilt" angle	0°
Software Parameters	
Reading Mode	Linear

For Tilt angles of 45°, the reading performance is reduced by approximately 10%.

6.4.6 Oscillating Mirror Long Range Models

DS5100-2x20 10 mils - 0.25 mm

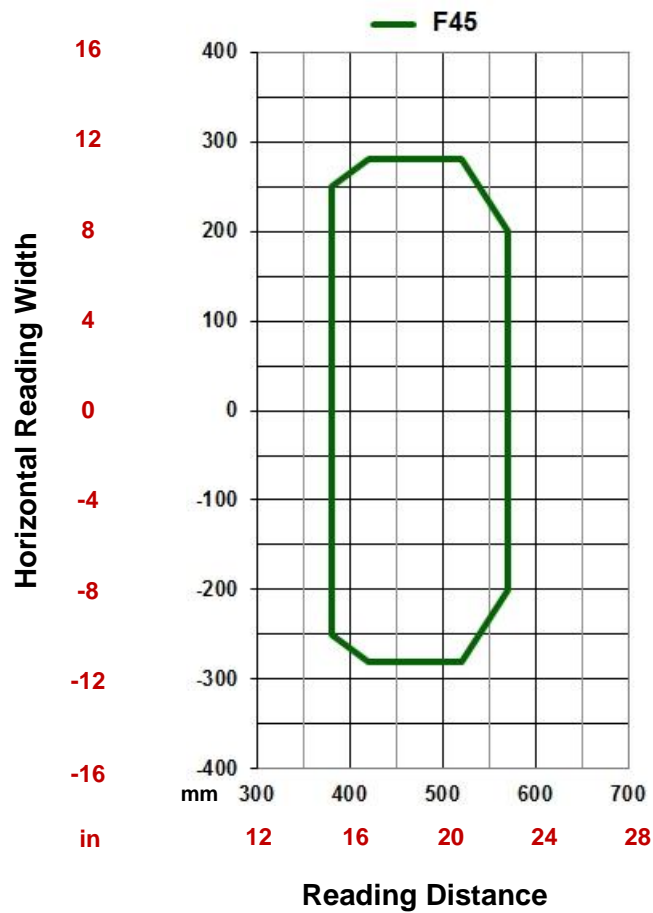

NOTE: (0,0) is the center of the laser beam output window.

CONDITIONS

Hardware Settings	
Code Symbology	Code 128
PCS	0.90
"Pitch" angle	0°
"Skew" angle	15°
"Tilt" angle	±45°
Software Parameters	
Reading Mode	Linear

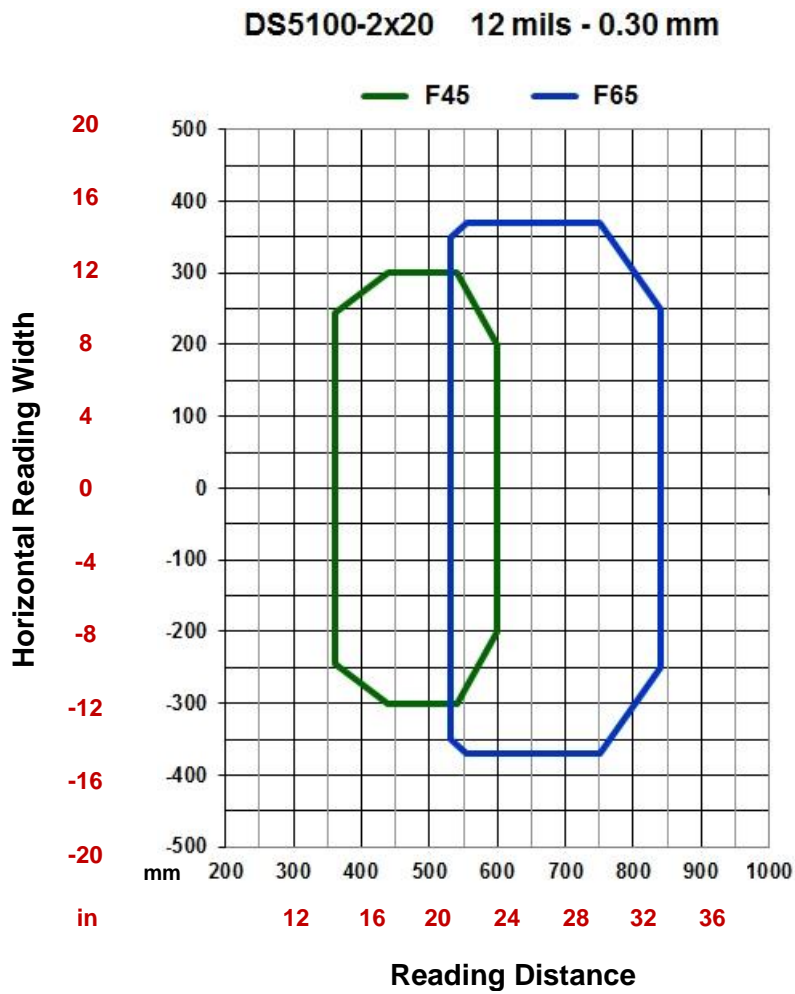

NOTE: (0,0) is the center of the laser beam output window.

CONDITIONS

Hardware Settings	
Code Symbology	Code 128
PCS	0.90
"Pitch" angle	0°
"Skew" angle	15°
"Tilt" angle	±45°
Software Parameters	
Reading Mode	Linear

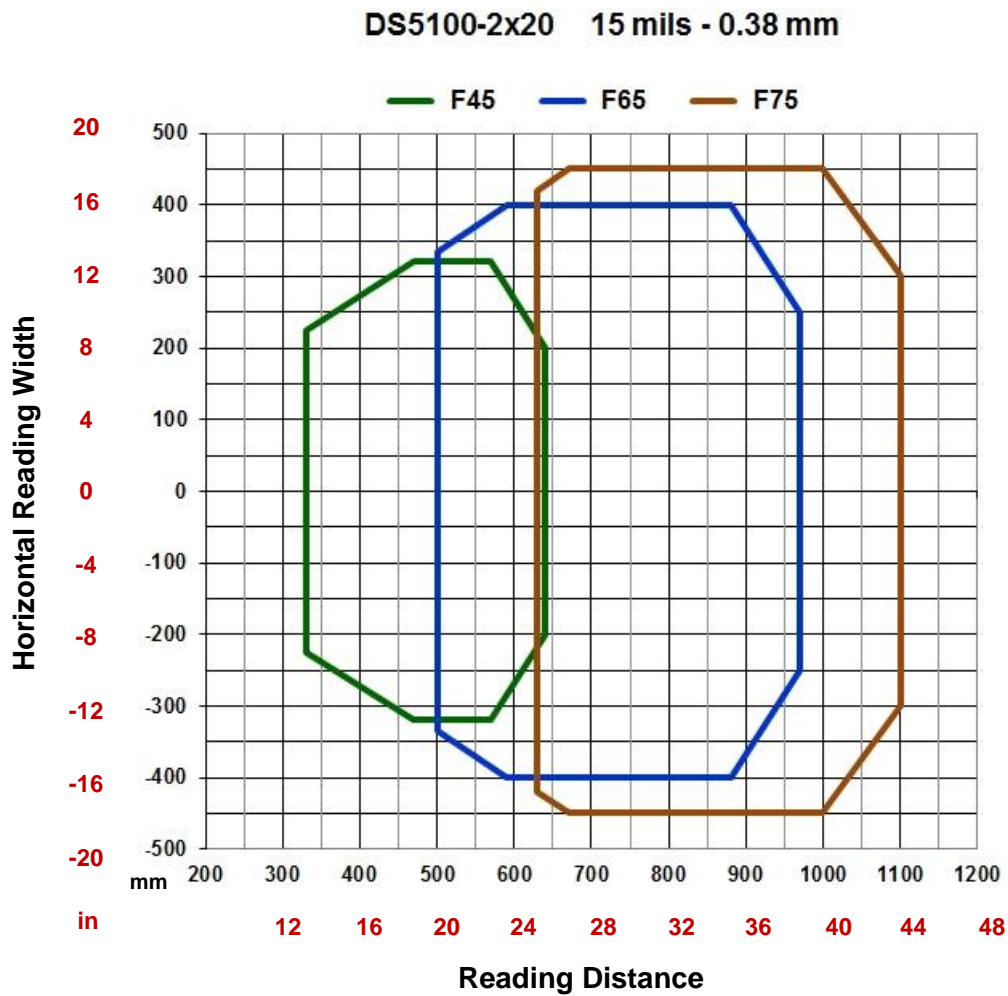

NOTE: (0,0) is the center of the laser beam output window.

CONDITIONS

Hardware Settings	
Code Symbology	Code 128
PCS	0.90
"Pitch" angle	0°
"Skew" angle	15°
"Tilt" angle	±45°
Software Parameters	
Reading Mode	Linear

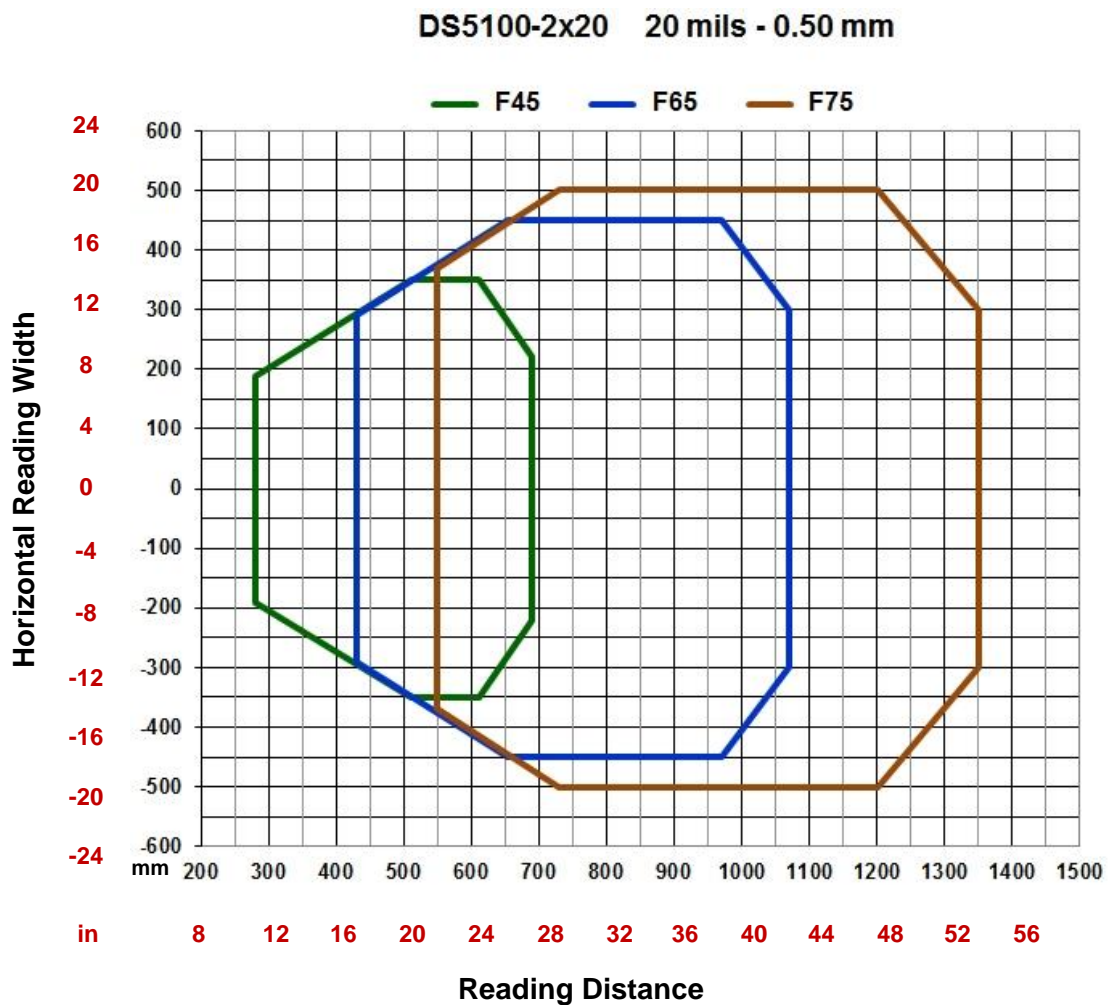

NOTE: (0,0) is the center of the laser beam output window.

CONDITIONS

Hardware Settings	
Code Symbology	Code 128
PCS	0.90
"Pitch" angle	0°
"Skew" angle	15°
"Tilt" angle	±45°
Software Parameters	
Reading Mode	Linear

7 MAINTENANCE

7.1 CLEANING

Clean the laser beam output window periodically for continued correct operation of the reader.

Dust, dirt, etc. on the window may alter the reading performance.

Repeat the operation frequently in particularly dirty environments.

Use soft material and alcohol to clean the window and avoid any abrasive substances.



CAUTION: Clean the Laser Beam Output Window when the scanner is turned off or, at least, when the laser beam is deactivated.

8 TROUBLESHOOTING

8.1 GENERAL GUIDELINES

When wiring the device, pay careful attention to the signal name (acronym) on the CBX100/500 spring clamp connectors (chp. 4). If you are connecting directly to the scanner 25-pin connector pay attention to the pin number of the signals (Appendix A).

If you need information about a certain reader parameter you can refer to the Genius program help files.

Either connect the device and select the parameter you're interested in by pressing the F1 key, or select **Help/Parameters Help/5K Software Configuration Parameters Guide** from the command menu.

If you're unable to fix the problem and you're going to contact your local Datalogic office or Datalogic Partner or ARC, we suggest providing (if possible) the Device Configuration files (*.ddc). Connect through Genius and click the Save icon from the toolbar. Also note the exact Model, Serial Number and Order Number of the device.

TROUBLESHOOTING GUIDE	
Problem	Suggestions
Power On: the "Power On"/"Ready" LED is not lit	Is power connected? If using a power adapter (like PG 6000), is it connected to a wall outlet? If using rail power, does rail have power? If using CBX100, does it have power (check switch and LED)? Measure voltage either at pin 13 and pin 25 (for 25-pin connector) or at spring clamp Vdc and GND (for CBX).
On line Mode: TRIGGER LED is not lit (when external trigger activates)	Is sensor connected to I1A, I1B spring clamps (for CBX) or to pins 18 and 19 (for 25-pin connector)? Is power supplied to photo sensor? Are the photo sensor LEDS (if any) working correctly? Is the sensor/reflector system aligned?
On line Mode: TRIGGER LED is correctly lit but nothing happens (no reading results)	Is the software configuration consistent with the application condition (operating mode etc.)? In the Genius program select the Operating Mode branch and check for related parameters.
Serial On line Mode: the reader is not triggered (no reading results)	In the Genius program select the Operating Mode branch and check if Serial On Line is selected in the On Line Options. Are the Start – Stop characters correctly assigned? Is the serial trigger source correctly connected and configured?
On line Mode and Serial On Line: Reader doesn't respond correctly to the expected external signals end	In the Genius program select the Operating Mode branch and check the Reading Phase Timeout parameterization.
X-PRESS: X-PRESS functions don't work. The multifunction keypress has no effect.	Check if the multifunction key is Locked through the Key Functionality parameter. Check if the multifunction key is Partially Locked through the Key Functionality parameter. Only the X-PRESS Autolearn function will be enabled and will only read the Lock/Unlock programming barcode. A message indicating this state is shown on the DS5100 Display.
X-PRESS: X-PRESS functions don't work. LEDs light up but do not allow access to the functions.	Except for the Focus Lock/Unlock function, the X-PRESS functions don't work if the scanner motor or laser are turned off. Check if the motor or laser are turned off through the following parameters: <ul style="list-style-type: none"> • Beam Shutter = enabled • Scan Speed = Motor Off • Energy Saving>Serial Motor Off has been sent A message indicating one of these states is shown on the DS5100 Display.

TROUBLESHOOTING GUIDE	
Problem	Suggestions
<p>Reading: Not possible to read the target barcode (always returns No Read) or the Auto Setup procedure Fails.</p>	<p>Check synchronization of reading pulse with object to read: Is the scan line correctly positioned? Place barcode in the center of scan line and run Test mode (selectable by Genius as an Operating Mode). If you still have trouble, check the following:</p> <ul style="list-style-type: none"> • Is the reading distance within that allowed (see reading diagrams)? • Is the scanner correctly focused? • Is the Tilt angle too large? • Is the Skew angle less than 15° (direct reflection)? • Choose the Code Definition branch and enable different Code Symbologies (except Pharmacode). Length = Min and Max (variable). • Is the Bar Code quality sufficient? <p>If you had no success, try to perform the test using the BARCODE TEST CHART included with the product.</p>
<p>Communication: Device is not transmitting anything to the host</p>	<ul style="list-style-type: none"> • Is the serial cable connected? • Is the correct wiring respected? • Are serial host settings equivalent to the serial device setting? • If using CBX, be sure the RS485 termination switch is positioned to OFF.
<p>Communication: Data transferred to the host are incorrect, corrupted or incomplete</p>	<ul style="list-style-type: none"> • In the Genius program select the Data Communication Settings/Data Format/Standard Parameters branch and check the Header, Separators, and Terminator values • Also check the Code Field Length and Fill Character values. • Are the COM port parameters correctly assigned?
<p>Communication: Always returns the Reader Failure Character (<BEL> char as default)</p>	<ul style="list-style-type: none"> • Contact your local Datalogic office or Datalogic Partner or ARC, because either a Motor or Laser failure has occurred. • Note the exact model and Serial Number of the device.
<p>How do I obtain my units' serial numbers?</p>	<ul style="list-style-type: none"> • The device's serial number is printed on a label that is affixed to the body of the reader. • Serial numbers consist of 9 characters: one letter, 2 numbers, and another letter followed by 5 numbers.

9 TECHNICAL FEATURES

ELECTRICAL FEATURES		
Input Power		
Supply Voltage	10 - 30 Vdc; (24 Vdc \pm 10% for Subzero models)	
Maximum Consumption		
xx00 (Standard)	0.6 - 0.2 A; 6 W	
xx20 (OM)	0.75 - 0.25 A; 7.5 W	
xx05 (Subzero)	1.2 A; 28.8 W @ 24 Vdc	
xx25 (OM Subzero)	1.3 A; 31.2 W @ 24 Vdc	
Communication Interfaces		
Main Serial Interface	SW programmable: RS232; RS485 FD	
Baudrate	1200 - 115200	
Auxiliary	RS232	
Baudrate	1200 - 115200	
ID-NET	RS485 Half-Duplex	
Baudrate	Up to 1 MBaud	
Built-In Ethernet models	10/100 Mbit/s (supports TCP/IP, EtherNet/IP, Modbus TCP, Profinet-IO Class A)	
Built-In Profinet-IO models	100 Mbit/s (supports Profinet-IO Class B, EBC)	
Inputs		
Input 1 (External Trigger), Input 2	Optocoupled, polarity insensitive	
Voltage	10 to 30 Vdc	
Current Consumption	12 mA max.	
Minimum Pulse Duration	5 ms.	
Outputs		
Output 1, Output 2	Optocoupled	
V _{CE}	30 Vdc max.	
Collector Current	40 mA continuous max.; 130 mA pulsed max.	
V _{CE saturation}	1V max. at 10 mA	
Power Dissipation	80 mW max. at 45 °C (ambient temperature)	
OPTICAL FEATURES		
Light Source	Semiconductor laser diode	
Wave Length	In the range 630 to 680 nm	
Safety Class	Class 2 - EN 60825-1; CDRH	
READING FEATURES (Note 1)		
Scan Rate (software programmable)	800 scans/sec	
Aperture Angle	65°	
Oscillating Amplitude (OM models)	40° \pm 2° (-5° to 35°)	
Oscillating Frequency (OM models)	0.2 to 20 Hz; 5 Hz max @ 40°; 20 Hz max @ 10°	
Maximum Reading Distance	See reading diagrams	
Maximum Resolution	See reading diagrams	
ENVIRONMENTAL FEATURES		
	STD and OM	Subzero
Operating Temperature (Note 2)	0° to +50 °C (+32° to +122 °F)	-35° to +50 °C (-31° to +122 °F) (Note 3)
Storage Temperature	-20° to +70 °C (-4° to +158 °F)	-35° to +70 °C (-31° to +158 °F)
Humidity max.	90% non condensing	
Vibration Resistance (Note 4)	14 mm @ 2 to 10 Hz; 1.5 mm @ 13 to 55 Hz;	
EN 60068-2-6	2 g @ 70 to 500 Hz; 2 hours on each axis	
Shock Resistance	30g; 11 ms;	
EN 60068-2-27	3 shocks on each axis	
Protection Class – EN 60529	IP65	
Ambient Light Rejection	30,000 LUX	

Note 1: Further details given in par. 6.3.

Note 2: If the reader is used in high temperature environments (over 40 °C), use of the Beam Shutter is advised (see the Genius configuration program) and/or a thermally conductive support (such as the metal bracket provided).

Note 3: The Operating Temperature is guaranteed under the following conditions: no direct ventilation on the scanner, fixed working environment (no rapid temperature changes). At -35 °C, a 20 min warm-up period is required before the scanner is ready to read barcodes.

Note 4: Product not installed on provided bracket.

A ALTERNATIVE CONNECTIONS FOR SERIAL MODELS

The connector pinouts and notes given in this appendix are for custom cabling applications.

POWER, COM AND I/O CONNECTOR

The scanner is equipped with a cable ending in a 25-pin male D-sub connector for connection to the power supply, serial interfaces and input/output signals. The details of the connector pins are indicated in the following table:

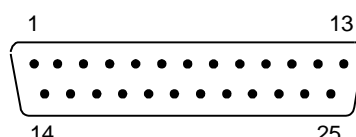

Figure 76 - 25-pin Male D-sub Connector

25-pin D-sub male connector pinout			
Pin	Name	Function	
13, 9	Vdc	Power supply input voltage +	
25, 7	GND	Power supply input voltage -	
1	CHASSIS	Cable shield connected to chassis	
18	I1A	External Trigger A (polarity insensitive)	
19	I1B	External Trigger B (polarity insensitive)	
6	I2A	Input 2 A (polarity insensitive)	
10	I2B	Input 2 B (polarity insensitive)	
8	O1+	Output 1 +	
22	O1-	Output 1 -	
11	O2+	Output 2 +	
12	O2-	Output 2 -	
20	RX	Auxiliary RS232 RX	
21	TX	Auxiliary RS232 TX	
23	ID+	ID-NET network +	
24	ID-	ID-NET network -	
14, 15, 16, 17	NC	Not Connected	
Pin	Name	RS232	RS485 Full-Duplex
2	MAIN INTERFACE (SW SELECTABLE) Reference to GND	TX	TX+
3		RX	*RX+
4		RTS	TX-
5		CTS	*RX-

* Do not leave floating, if not used connect to GND.

In order to meet EMC requirements:

- connect the reader chassis to the plant earth ground by means of a flat copper braid shorter than 100 mm;
- connect your cable shield to the locking ring nut of the connector.

ID-NET NETWORK TERMINATION

The network must be properly terminated by a 120 Ohm resistor at the first and last reader of the network.

INPUTS

There are two optocoupled polarity insensitive inputs available on the 25-pin D-sub connector of the reader: Input 1 (External Trigger) and Input 2, a generic input.

The electrical features of both inputs are:

V_{AB} Max.	I_{IN} Max.
30 V	12 mA

The relative pins on the 25-pin D-sub connector are:

Pin	Name	Function
9	Vdc	Power Supply input voltage +
18	I1A	External Trigger A (polarity insensitive)
19	I1B	External Trigger B (polarity insensitive)
6	I2A	Input 2 A (polarity insensitive)
10	I2B	Input 2 B (polarity insensitive)
7	GND	Power Supply input voltage -

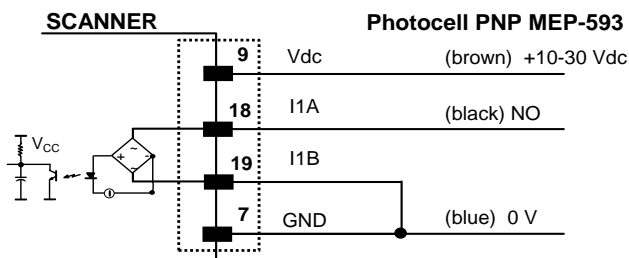

Figure 77 – MEP-593 PNP Photocell Connections Using Scanner Power

OUTPUTS

Two general purpose optocoupled but polarity sensitive outputs are available on the 25-pin D-sub connector.

The pinout is the following:

Pin	Name	Function
8	O1+	Configurable digital output 1 +
22	O1-	Configurable digital output 1 -
11	O2+	Configurable digital output 2 +
12	O2-	Configurable digital output 2 -

The electrical features of the two outputs are the following:

$V_{CE\ max} = 30\ Vdc$

40 mA continuous max.; 130 mA pulsed max.

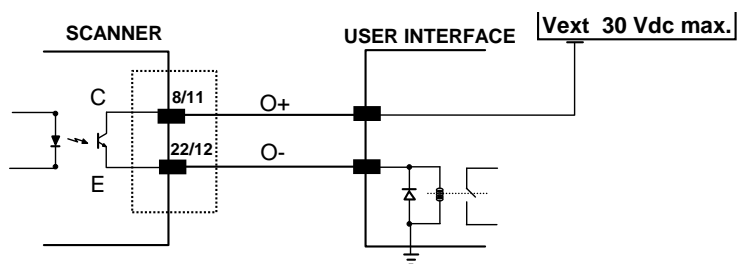

Figure 78 - Open Emitter Output Connections

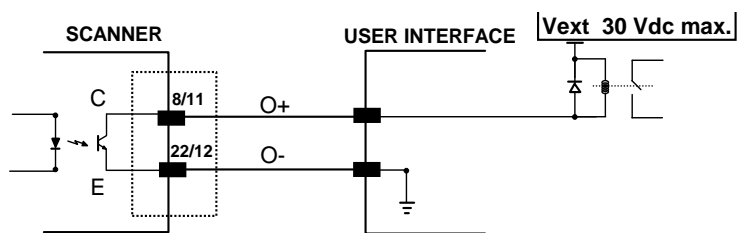
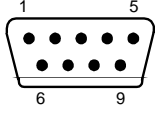
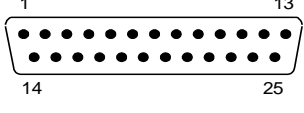

Figure 79 - Open Collector Output Connections

USER INTERFACE - SERIAL HOST

RS232 PC-side connections			
 <p>9-pin male connector</p>		 <p>25-pin male connector</p>	
Pin	Name	Pin	Name
2	RX	3	RX
3	TX	2	TX
5	GND	7	GND
7	RTS	4	RTS
8	CTS	5	CTS

How To Build A Simple Interface Test Cable:

The following wiring diagram shows a simple test cable including power, external (push-button) trigger and PC RS232 COM port connections.

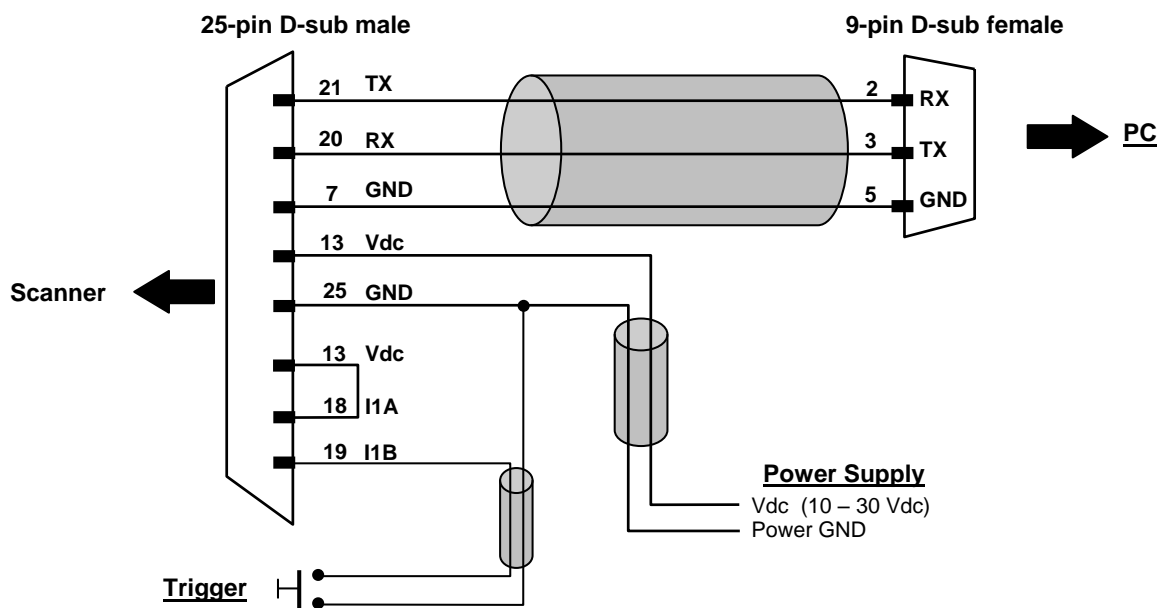

Figure 80- Test Cable for Serial Model Scanners

B ALTERNATIVE CONNECTIONS FOR ETHERNET MODELS

The connector pinouts and notes given in this appendix are for custom cabling applications.

POWER, COM AND I/O CONNECTOR

The scanner is equipped with an M12 17-pin male connector for connection to the power supply, serial interfaces and input/output signals. The details of the connector pins are indicated in the following table:

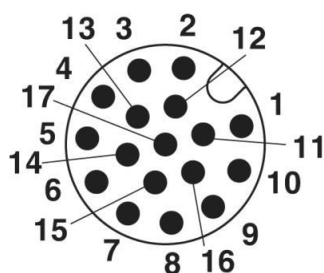

Figure 81 – M12 17-pin male COM, I/O and Power Connector

Power, COM and I/O Connector Pinout			
Pin	Name	Function	
1	Vdc	Power supply input voltage +	
2	GND	Power supply input voltage -	
Connector case	CHASSIS	Connector case provides electrical connection to the chassis	
6	I1A	External Trigger A (polarity insensitive)	
5	I1B	External Trigger B (polarity insensitive)	
13	I2A	Input 2 A (polarity insensitive)	
3	I2B	Input 2 B (polarity insensitive)	
9	O1	Output 1	
8	O2	Output 2 (NPN or PNP short circuit protected and software programmable)	
16	NC	Not connected	
14	RX	Auxiliary RS232 RX	
4	TX	Auxiliary RS232 TX	
7	ID+	ID-NET network +	
15	ID-	ID-NET network -	
Pin	Name	RS232	RS485/422 Full-Duplex
17	MAIN INTERFACE (SW SELECTABLE) Reference to GND	TX	TX+
11		RX	*RX+
12		RTS	TX-
10		CTS	*RX-

* Do not leave floating, if not used connect to GND.

In order to meet EMC requirements:

- connect the reader chassis to the plant earth ground by means of a flat copper braid shorter than 100 mm;
- connect your cable shield to the locking ring nut of the connector.

ON-BOARD ETHERNET CONNECTOR

A Standard M12 D-Coded female connector is provided for the on-board Ethernet connection. This interface is IEEE 802.3 10 BaseT and IEEE 802.3u 100 BaseTx compliant. Use Cat 5e or superior cables.

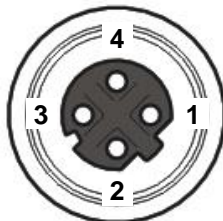

Figure 82 - M12 D-Coded Female Ethernet Network Connector

On-Board Ethernet Network Connector Pinout		
Pin	Name	Function
1	TX +	Transmitted data (+)
2	RX +	Received data (+)
3	TX -	Transmitted data (-)
4	RX -	Received data (-)

ID-NET NETWORK TERMINATION

The network must be properly terminated by a 120 Ohm resistor at the first and last reader of the network.

INPUTS

There are two optocoupled polarity insensitive inputs available on the M12 17-pin connector of the reader: Input 1 (External Trigger) and Input 2, a generic input.

The electrical features of both inputs are:

V_{AB} Max.	I_{IN} Max.
30 V	12 mA

The relative pins on the M12 17-pin connector are:

Pin	Name	Function
1	Vdc	Power Supply input voltage +
6	I1A	External Trigger A (polarity insensitive)
5	I1B	External Trigger B (polarity insensitive)
13	I2A	Input 2 A (polarity insensitive)
3	I2B	Input 2 B (polarity insensitive)
2	GND	Power Supply input voltage -

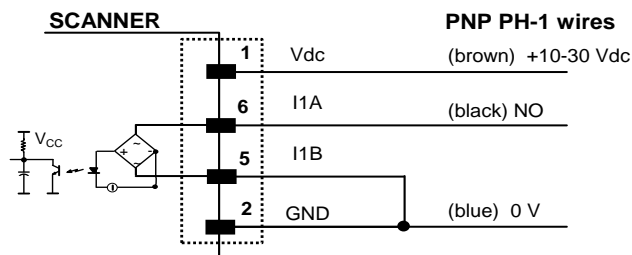

Figure 83 - PH-1 Photocell (PNP) External Trigger Using Scanner Power

OUTPUTS

Two general purpose **non opto-isolated** but short circuit protected outputs are available on the M12 17-pin connector.

The pinout is the following:

Pin	Name	Function
9	O1	Configurable digital output 1
8	O2	Configurable digital output 2
2	GND	Output reference signal

The electrical features of the two outputs are the following:

Reverse-Polarity and Short-Circuit Protected

V_{OUT} ($I_{LOAD} = 0$ mA) max = 30 Vdc

V_{OUT} ($I_{LOAD} = 100$ mA) max = 3 Vdc

I_{LOAD} max = 100 mA

The output signals are fully programmable being determined by the configured Activation/Deactivation events, Deactivation Timeout or a combination of the two. Refer to the Digital I/O Setting folder in the Genius Help On Line for further details.

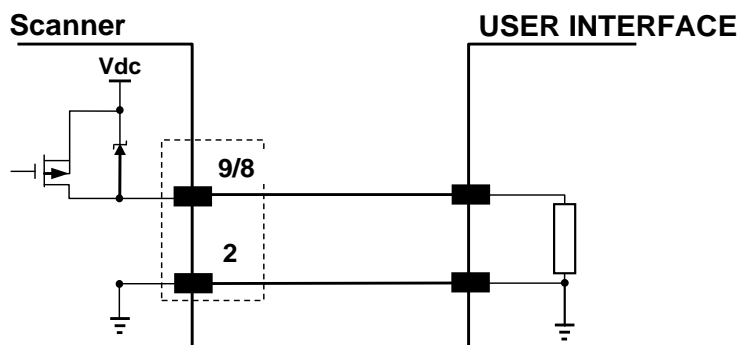

Figure 84 - PNP Output Connection

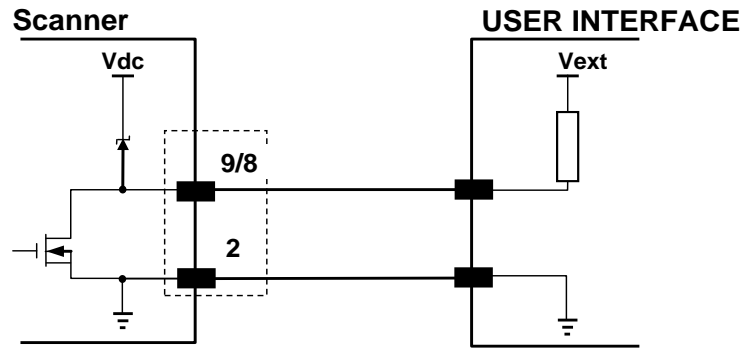

Figure 85 - NPN Output Connection



CAUTION: For NPN output connections, the external interface voltage (V_{ext}) must not exceed the scanner power supply source voltage (V_{dc}) otherwise correct output functioning cannot be guaranteed.

C CONNECTIONS FOR PROFINET-IO MODELS

ON-BOARD PROFINET-IO CONNECTORS (2)

Two Standard M12 D-Coded female connectors are provided for the on-board PROFINET-IO connection. This interface is IEEE 802.3u 100 BaseTx compliant.

Use accessory ETH CABLE M12-M12 cables or Cat 5e or superior cables.

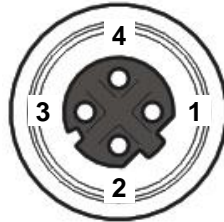

Figure 86 - M12 D-Coded 4-pin Female PROFINET-IO Network Connector

On-Board Ethernet Network Connector Pinout			
Pin	Name	Function	
1	TX +	Transmitted data (+)	
2	RX +	Received data (+)	
3	TX -	Transmitted data (-)	
4	RX -	Received data (-)	

POWER + INPUT (TRIGGER)

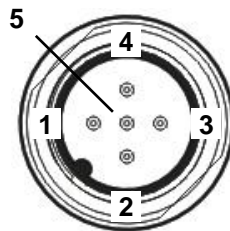

Figure 87 - M12 A-Coded 5-pin Male Power Connector

Power Connector Pinout			
Pin	Name	Function	CS-A1-02
1	Vdc	Power supply input voltage +	Brown
2	I1A	External Trigger Input (polarity insensitive)	White
3	GND	Power supply input voltage -	Blue
4	I1B	External Trigger Input (polarity insensitive)	Black
5	NC	Not Connected	nc

The CS-A1-02 or AS-I accessory power cables can be used to connect to the power source. The CS-A1-02 cables can also be used to connect to the input trigger signal.

GLOSSARY

ACR4 (Advanced Code Reconstruction)

This is a powerful code reconstruction technology (ACR 4). The new fourth generation ACR considerably increases the code reconstruction reading capability in the case of damaged or very tilted barcodes.

Aperture

Term used on the required CDRH warning labels to describe the laser exit window.

Barcode

A pattern of variable-width bars and spaces which represents numeric or alphanumeric data in machine-readable form. The general format of a barcode symbol consists of a leading margin, start character, data or message character, check character (if any), stop character, and trailing margin. Within this framework, each recognizable symbology uses its own unique format.

Barcode Label

A label that carries a barcode and can be affixed to an article.

Baud Rate

A unit used to measure communications speed or data transfer rate.

CDRH (Center for Devices and Radiological Health)

This organization (a service of the Food and Drug Administration) is responsible for the safety regulations governing acceptable limitations on electronic radiation from laser devices. Datalogic devices are in compliance with the CDRH regulations.

Code Positioning

Variation in code placement that affects the ability of a scanner to read a code. The terms Pitch, Skew, and Tilt deal with the angular variations of code positioning in the X, Y and Z axes. See pars. 3.2.1 and 3.4. Variations in code placement affect the pulse width and therefore the decoding of the code. Pulse width is defined as a change from the leading edge of a bar or space to the trailing edge of a bar or space over time. Pulse width is also referred to as a transition. Tilt, pitch, and skew impact the pulse width of the code.

Decode

The process of translating a barcode into data characters using a specific set of rules for each symbology.

Decoder

As part of a barcode reading system, the electronic package which receives the signals from the scanner, performs the algorithm to interpret the signals into meaningful data and provides the interface to other devices. The decoder is normally integrated into the scanner.

EAN

European Article Number System. The international standard barcode for retail food packages.

FLASH

An on-board non-volatile memory chip.

Full Duplex

Simultaneous, two-way, independent transmission in both directions.

Host

A computer that serves other terminals in a network, providing services such as network control, database access, special programs, supervisory programs, or programming languages.

Interface

A shared boundary defined by common physical interconnection characteristics, signal characteristics and meanings of interchanged signals.

LED (Light Emitting Diode)

A low power electronic device that can serve as a visible or near infrared light source when voltage is applied continuously or in pulses. It is commonly used as an indicator light and uses less power than an incandescent light bulb but more than a Liquid Crystal Display (LCD). LEDs have extremely long lifetimes when properly operated.

Parameter

A value that you specify to a program. Typically parameters are set to configure a device to have particular operating characteristics.

Picket-Fence Orientation

When the barcode's bars are positioned vertically on the product, causing them to appear as a picket fence. The first bar will enter the scan window first. See par. 6.2.2.

Pitch

Rotation of a code pattern about the X-axis. The normal distance between center line or adjacent characters. See pars. 3.2.1 and 3.4.

Position

The position of a scanner or light source in relation to the target of a receiving element.

Protocol

A formal set of conventions governing the formatting and relative timing of message exchange between two communicating systems.

Resolution

The narrowest element dimension, which can be distinguished by a particular reading device or printed with a particular device or method.

RS232

Interface between data terminal equipment and data communication equipment employing serial binary data interchange.

RS485

Interface that specifies the electrical characteristics of generators and receivers for use in balanced digital multipoint systems.

Scanner

A device that examines a printed pattern (barcode) and either passes the uninterpreted data to a decoder or decodes the data and passes it onto the Host system.

Serial Port

An I/O port used to connect a scanner to your computer, identifiable by a 9-pin or 25-pin connector.

Signal

An impulse or fluctuating electrical quantity (i.e.: a voltage or current) the variations of which represent changes in information.

Skew

Rotation about the Y-axis. Rotational deviation from correct horizontal and vertical orientation; may apply to single character, line or entire encoded item. See pars. 3.2.1 and 3.4.

Step-Ladder Orientation

When the barcode's bars are positioned horizontally on the product, causing them to appear as a ladder. The ends of all bars will enter the scan window first. See par. 6.2.1.

Symbol

A combination of characters including start/stop and checksum characters, as required, that form a complete scannable barcode.

Tilt

Rotation around the Z axis. Used to describe the position of the barcode with respect to the laser scan line. See pars. 3.2.1 and 3.4.

Trigger Signal

A signal, typically provided by a photoelectric sensor or proximity switch, which informs the scanner of the presence of an object within its reading zone.

UPC

Acronym for Universal Product Code. The standard barcode type for retail food packaging in the United States.

Visible Laser Diode

A light source used in scanners to illuminate the barcode symbol. Generates visible red light at wavelengths between 630 and 680 nm.

INDEX

A

Accessories, 39
ACR 4, 90
Alternative Connections for Ethernet Models, 138
Alternative Connections for Serial Models, 134
Automatic Scanner Replacement, 29
Auxiliary RS232 Interface, 65

B

Backup & Restore, 26

C

CE Compliance, ix
Cleaning, 128
Code Verifier, 69
Safety and Compliance Notices, vii
Connections for Profinet-IO Models, 142
Connector
 COM, I/O and Power, 138
 On-board Ethernet, 139
 On-board Profinet-IO, 142
 Power, COM and I/O, 134

D

Display, 30
Display Messages, 30

E

EBC™ Networks, 78
Electrical Installation, 56
Ethernet Networks, 74
External Memory Backup & Restore, 26

F

FCC Compliance, ix

G

General View, xii
GFC-40, 53
Glossary, 143

H

Handling, x

I

ID-NET Cables, 60
ID-NET Interface, 60
ID-NET Multidata Networks, 88

ID-NET Network Termination, 65, 135, 139
ID-NET Response Time, 61
ID-NET Synchronized Networks, 83
Inputs, 66, 135, 139
IP Address Alignment Using Genius Discovery, 37

L

Laser Safety, vii
LEDs, 20
Linear Code Reading, 96

M

Main Serial Interface, 57
Mechanical Installation, 42, 43
Model Description, 34
Mounting DS5100, 50

O

Oscillating Mirror Models, 35
Other Layouts, 89
Outputs, 69, 136, 140

P

Package Contents, 42
Pass-Through, 89
Patents, vi
Performance, 98
Picket-Fence Mode, 97
Point-to-Point, 72
Positioning, 54
Power Supply, viii, 57
Product Description, 19
Profinet-IO Networks, 75

R

Reading Diagrams, 100
Reading Features, 90
References, vi
Reset Scanner, 26
RS232 Interface, 58
RS485 Full Duplex, 59

S

Step-Ladder Mode, 96
Subzero Temperature Models, 36
Support Through The Website, vi

T

Technical Features, 132
Troubleshooting, 129
Typical Layouts, 72



 **DATALOGIC**

www.datalogic.com